

Bang & Olufsen

Beomaster 7000

Type 2341, 2342, 2343,
2344, 2345

Beomaster 6500

Corrections

Beomaster 7000

Type 2341, 2342, 2343, 2344, 2345

Beomaster 6500

Corrections

10-91 3538794 Indklæbes i Serviceanvisningen Beomaster 6500 (3538751)
Paste into Service Manual Beomaster 6500 (3538751)
In Serviceanleitung Beomaster 6500 (3538752) einkleben
A coller le Manuel d'entretien pour Beomaster 6500 (3538752)



SERVICE ANVISNING
SERVICE MANUAL
SERVICEANLEITUNG
MANUAL d'ENTRETIE

DIAGRAM A AM-FM, TUNER, IF, STEREO DECODER (Type 2341, 2342)

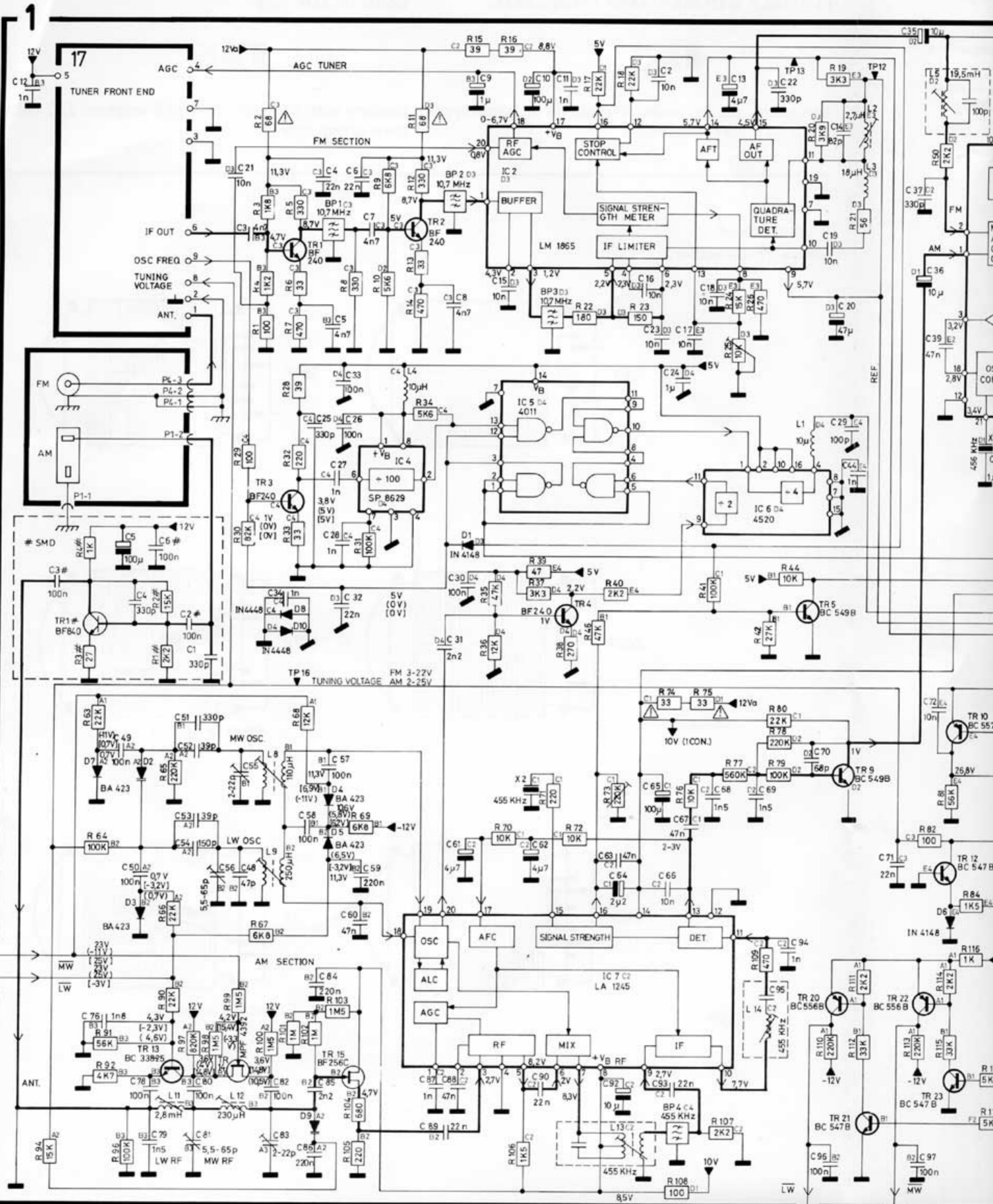

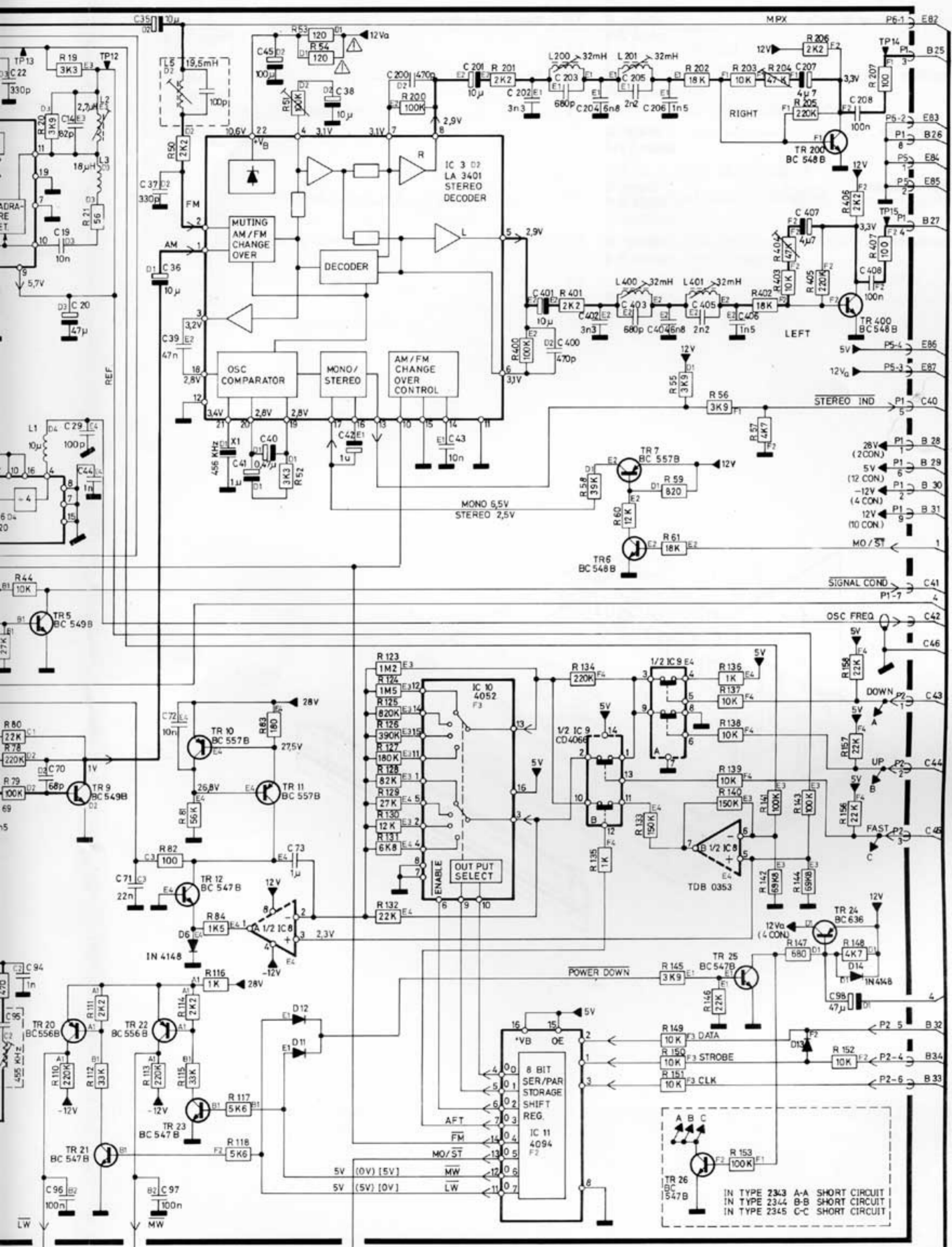
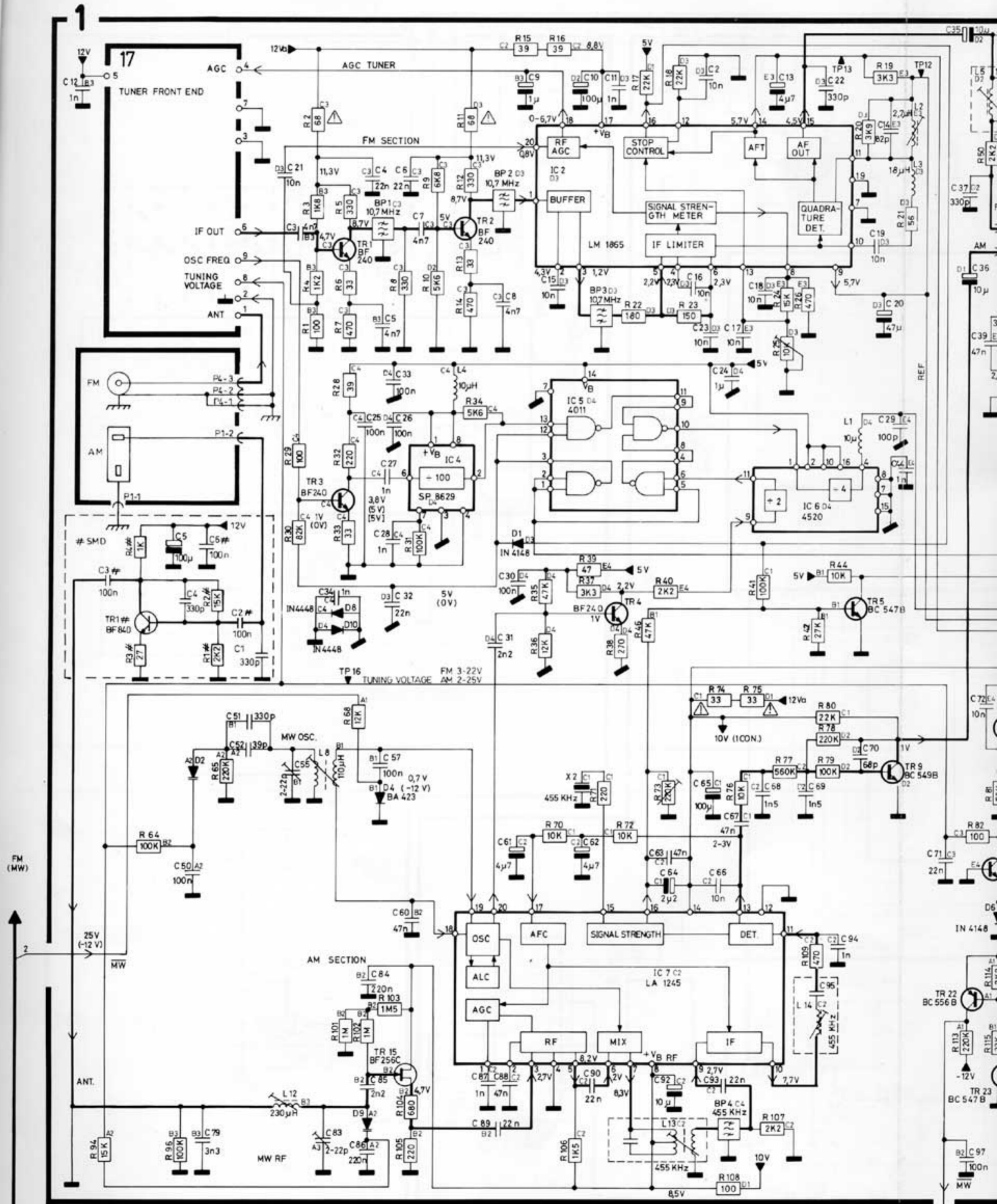
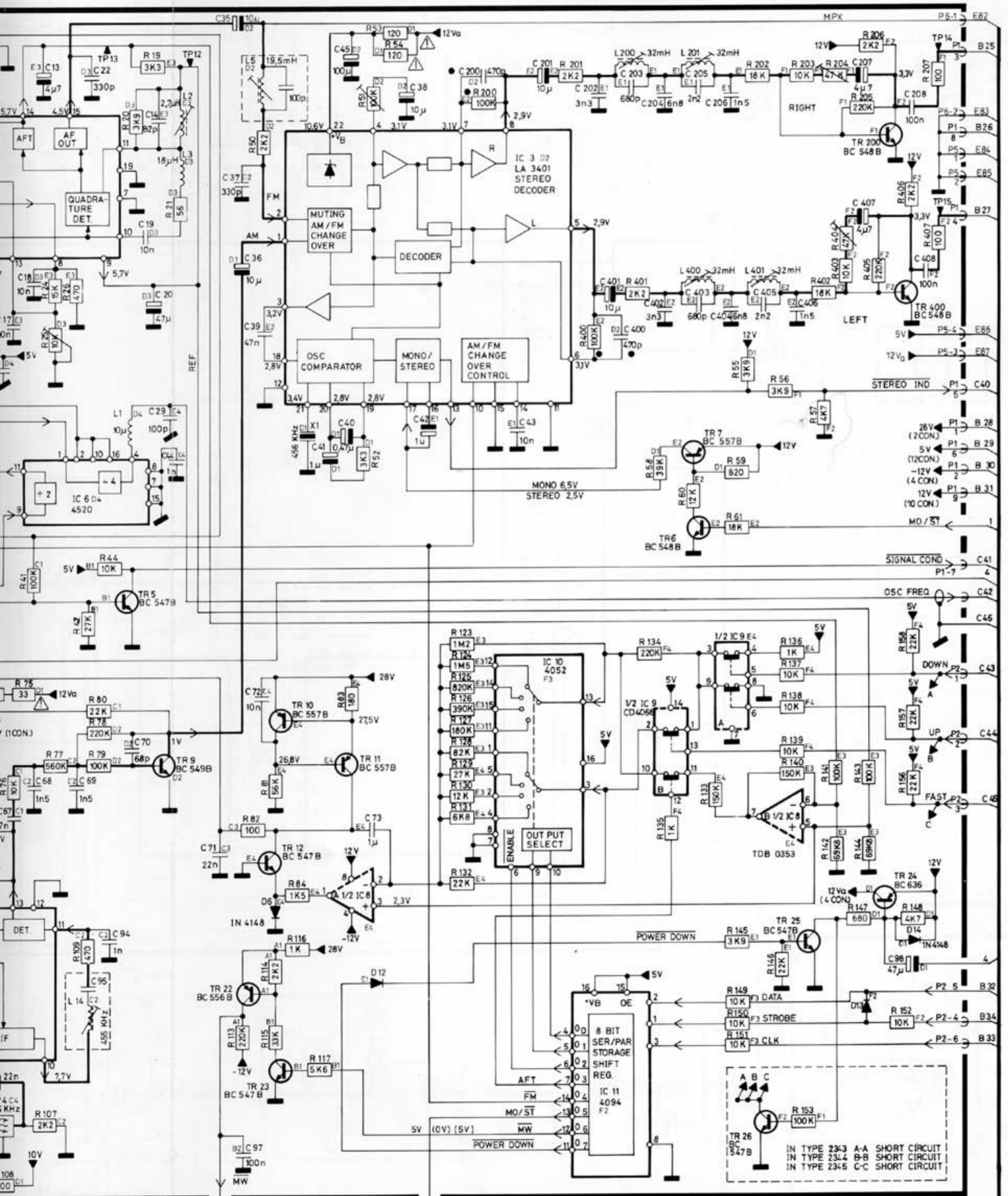
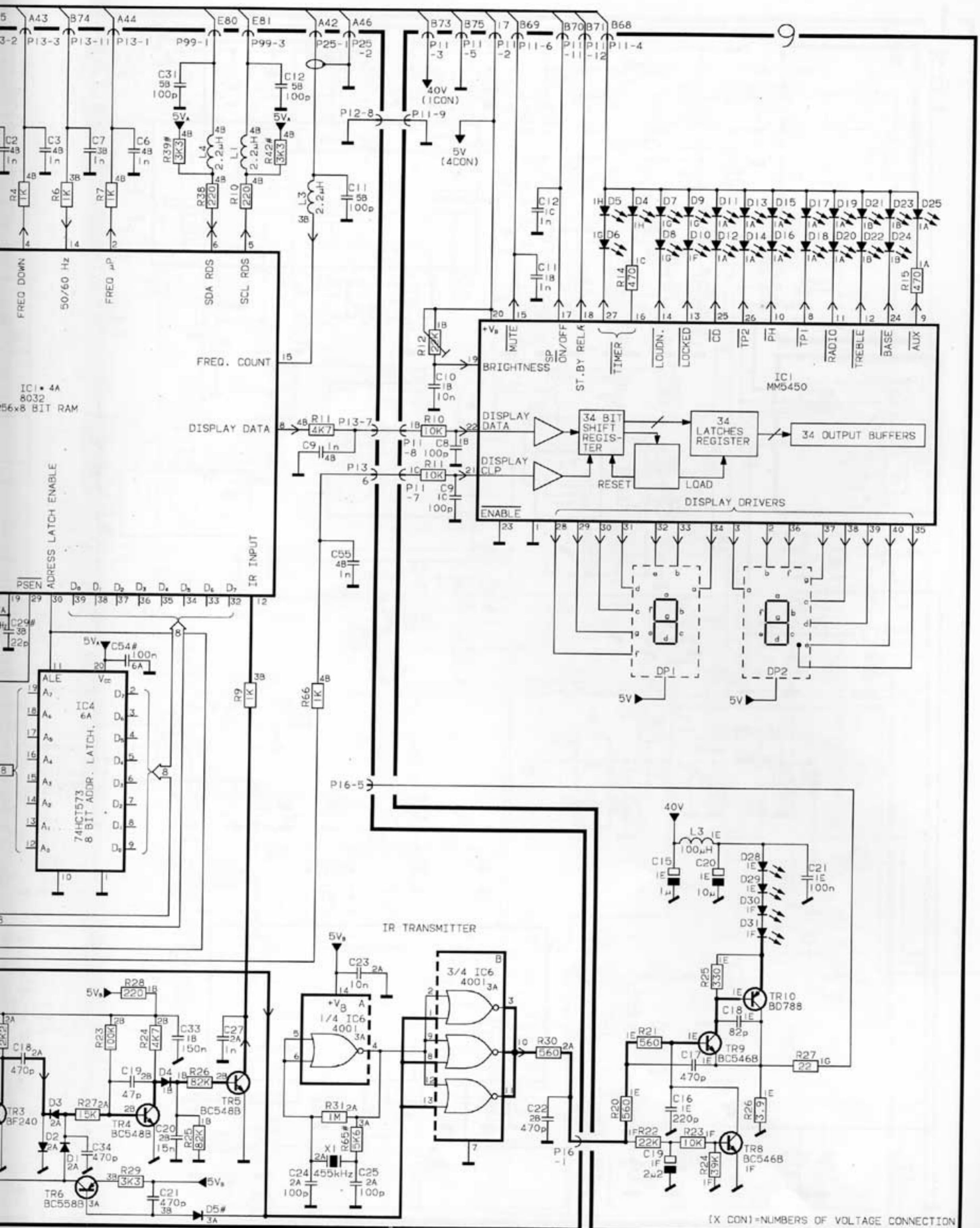

DIAGRAM A AM-FM, TUNER, IF, STEREO DECODER (Type 2343, 2344, 2345)



(X CON) = NUMBER OF VOLTAGE CONNECTIONS





- A86
- A87
- A85
- A84
- A82
- A83

Corrections for Beomaster 6500

DIAGRAMS

Page 2-4:

2R18 must be 5020881 22Ω 5% 1/4W

An kondensator part no. 4200510 10μ 20% 16V has been added to the collector on 2TR16.

3R81 and 3R84 5010092 220Ω 5% 1/4W has been added:

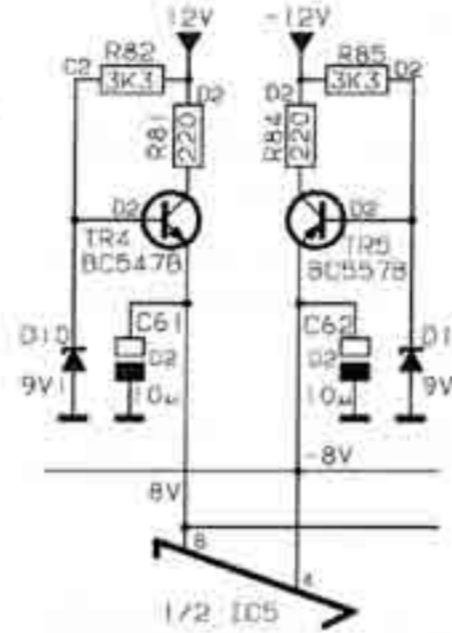

7TR2 BC338 is an NPN transistor. Emitter to the ground.

Page 2-5:

Connection to pin 7 (TEST) on 4IC2 is deleted.

The value of 4X1 is 11.0592MHz

Part no. on 4IC1* must be 8341069

Part no. on 4IC4* must be 8341309

Part no. on PCB 9 must be 8001284

List of Electrical Parts page 3-3

2C6, 2C7 must be 4200530 10000μF 20% 50V

2RL6 is named wrong. 2RL1 is correct

List of Mechanical Parts page 4-3

12 Modul part no. must be 8002821

9504	2804055 Wheel
9510	2854128 Arm
9511	2576050 Spacer

Accessories page 4-4

8087016 IR-sensor kit

DIAGRAM E RADIO DATA SYSTEM

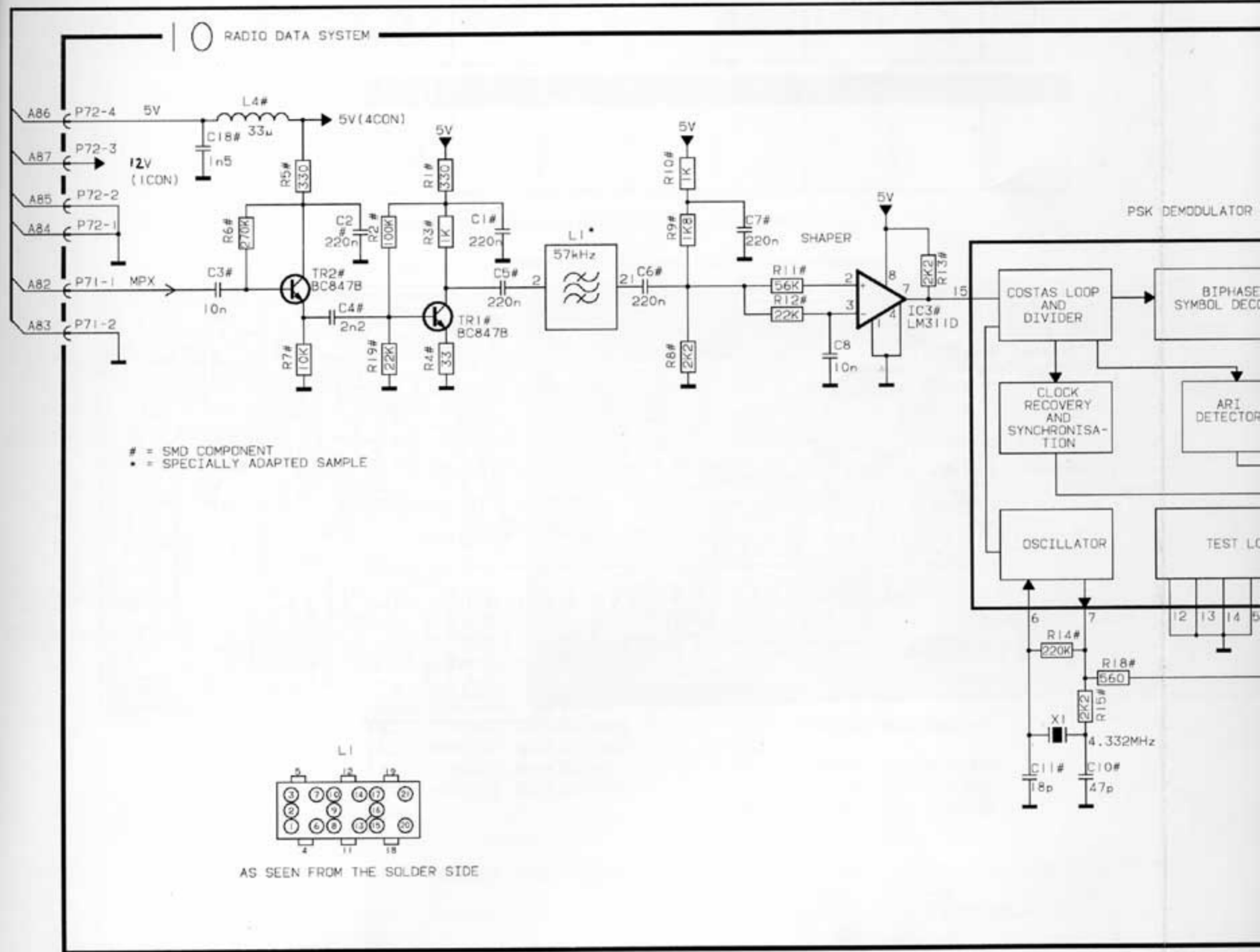

SMD Survey

- : rear side
- : rear side

PCB 1, Amp. f. AM loop antenna

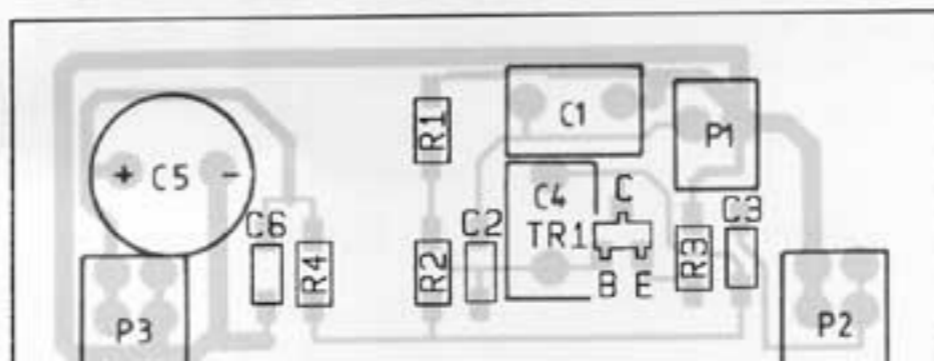

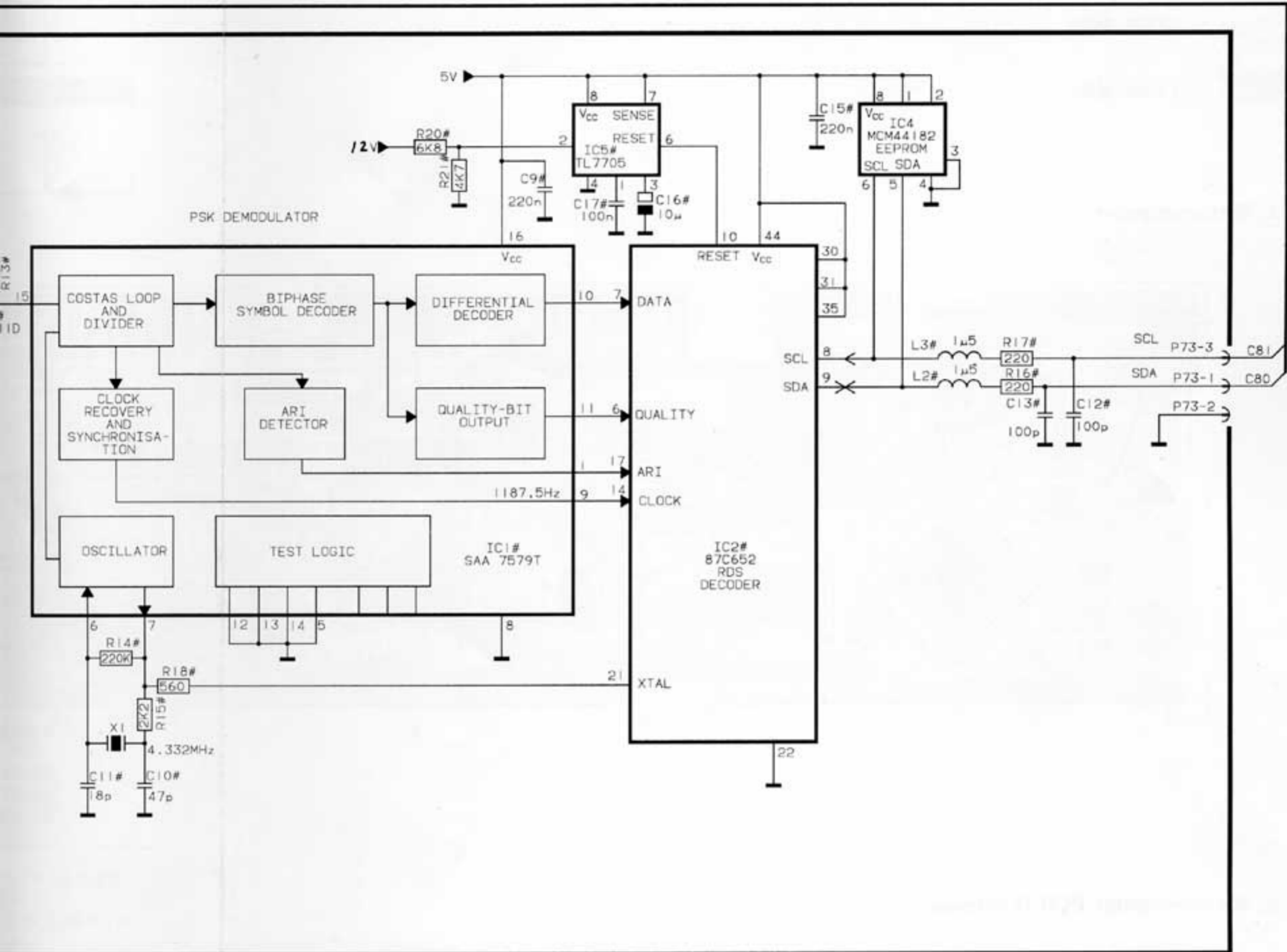

PCB 10, RDS

