

# ALBA ROVER

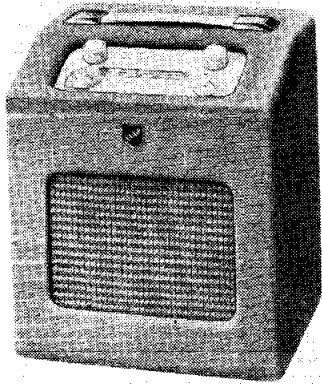

Model 2725

Four-valve two-waveband AC-DC-battery portable with self-contained frame aerial. Housed in fabric covered cabinet fitted with plastic carrying handle. Suitable for operating from all-dry batteries and 200-250V AC-DC mains. Weight with batteries, 13½ lb. Made by A. J. Balcombe, Ltd., 52/58, Tabernacle Street, London, EC2.

**AERIAL.** The receiver is fitted with a MW frame aerial L1 and a LW loading coil L2, which are wired in series and connected across aerial tuning capacitor VC1 and coupled to g3 of heptode frequency changer V1.

On MW band L2 is shorted out by S1 and L1 is tuned by VC1 and trimmed by T2. On LW band S1 is open and L1, L2 are tuned by VC1 and trimmed by T1.

AVC decoupled by R5, C1 is led through L1, L2 to g3 of V1.

Primary L3, C4 of IFT1 is in the anode circuit.

Oscillator is connected in a tuned grid shunt fed circuit. The grid coils L7 (MW), L9 (LW) are switched by S2 to oscillator tuning capacitor VC2 and coupled by C6 to oscillator grid (g1) of V1. T3 (MW), T4 (LW) are trimmers and C9 (MW),

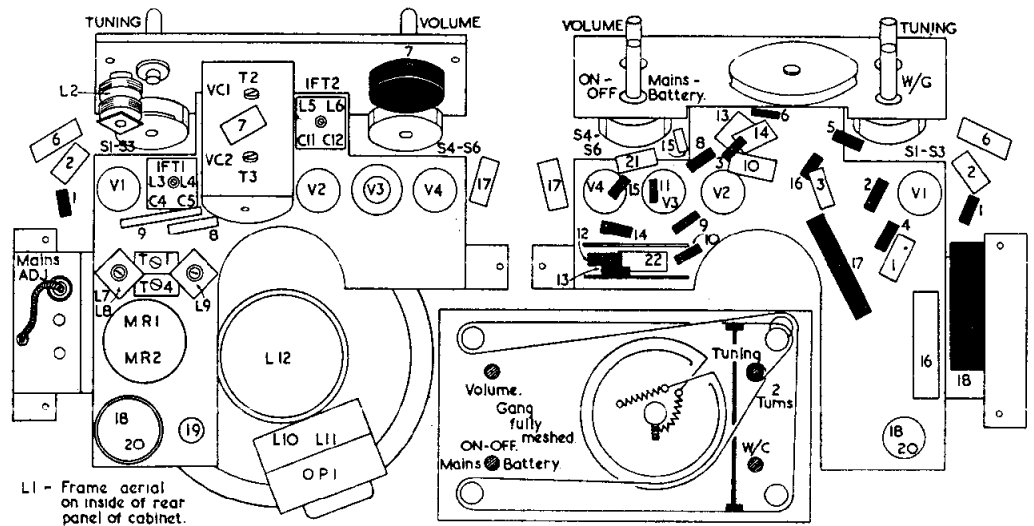

L1 - Frame aerial on inside of rear panel of cabinet.

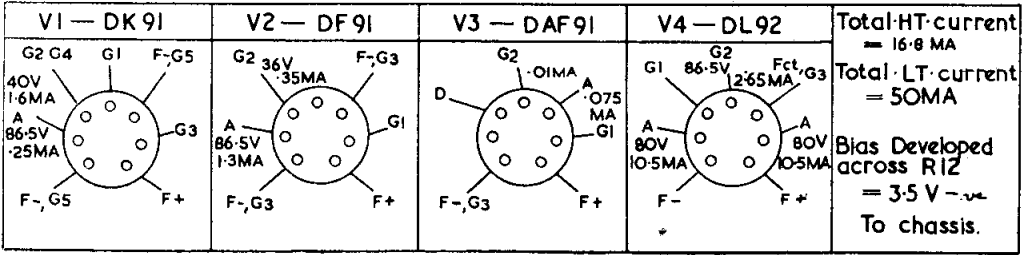
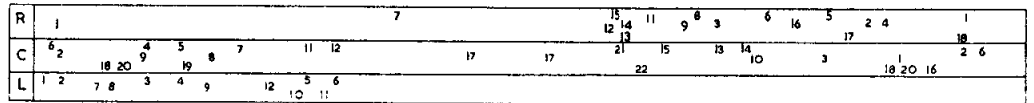

ALL READINGS TAKEN WITH BATTERY INPUT

**Total HT-current = 16.8 MA**  
**Total LT-current = 50MA**  
**Bias Developed across R12 = 3.5 V - - - To chassis.**

C8 (LW) are padders. Automatic bias for g1 is developed on C6 with R1 as leak. Anode reaction voltages are obtained inductively from L8 (MW) and capacitively from across padder C8 (LW) and are switched by S3 to oscillator anode (g2, g4) of V1, of which R2 is the load. IF amplifier operates at 470 kc/s. Secondary L4, C5 of IFT1 feeds signal and AVC voltages, decoupled by R5, C1 to IF amplifier V2. Screen voltage is obtained from R3 decoupled by C10. Suppressor is internally strapped to negative side

of filament. Primary L5, C11 of IFT2 is in the anode circuit. Signal rectifier. Secondary L6, C12 of IFT2 feeds signal to diode anode of V3. R7 the volume control, is the diode load and R6, C13, C14 an IF filter. AVC. The DC component of the rectified signal developed across R7 is divided by R5, R4 decoupled by C1 and applied to g3 of V1 and g1 of V2. R4 is returned to chassis through R11 for circuit stability. *Continued on page 8.*

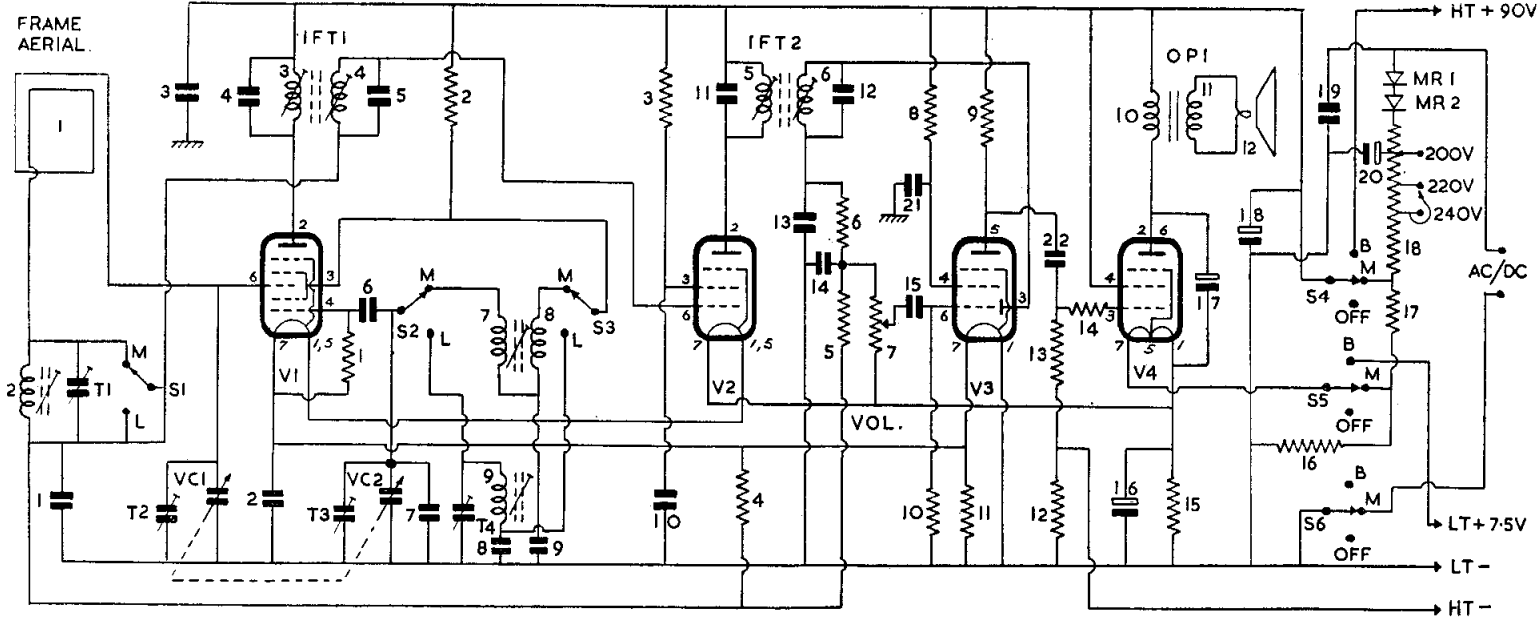

RESISTORS		
R	Ohms	Watts
1	100K	...
2	22K	...
3	68K	...
4	10M	...
5	4.7M	...
6	47K	...
7	2M	...
8	4.7M	...
9	1M	...
10	2.2M	...
11	220	...
12	220	...
13	1M	...
14	10K	...
15	330	...
16	10K	...
17	1,750	WW
18	2,300	WW
(Tapped at 200-550-900)		

CAPACITORS		
C	Capacity	Type
1	.05 Tubular 250V	...
2	.1 Tubular 150V	...
3	.1 Tubular 150V	...
4	100pF Mica	...
5	100pF Mica	...
6	500pF Silver Mica	...
7	15pF Silver Mica	...
8	250pF Silver Mica	...

INDUCTORS		
L	Capacity	Ohms
1	...	1.4
2	...	10.5
3	...	9
4	...	9
5	...	9
6	...	10
7	...	3
8	...	1.75
9	...	9.5
10	...	500
11	...	Very low
12	...	2.5

**AF amplifier.** C15 feeds signal from volume control R7 to pentode section of V3. Automatic bias for grid is developed on C15 with R10 as leak. Screen voltage is obtained from R8 decoupled by C21. Suppressor is internally strapped to negative side of filament. R9 is anode load.

**Output stage.** C22 feeds signal through stopper resistor R14 to pentode output amplifier V4. Grid is biased negatively by virtue of its filament being at the high potential side of LT supply. On battery operation anode current of V4 is reduced to prolong life of HT battery by increasing negative bias on g1 by returning its grid resistor R13 to chassis through R12 in the HT battery negative lead.

Screen voltage is obtained direct from HT line, decoupling being by C18. Suppressor is internally connected to centre tap of filament. Primary L10 of output matching transformer OP1 is in the anode circuit. C17 gives fixed tone control. Secondary L11 of OP1 feeds signal to a 5-in. PM speaker L12.

HT of 90V is provided by an Ever Ready Batrymax type B107, or alternatively from the mains. S4 switches the receiver HT line to whichever source of supply is desired.

C21 decouples HT battery and functions as smoothing capacitor on mains generated HT.

Input mains is rectified by the series connected metal rectifiers MR1, MR2, and applied through combined dropper and smoothing resistor R18 to S4, which in its mains position switches supply through to receiver HT line. Resistance-capacity smoothing is given by R18 with C18, C20.

To compensate for the lower resistance of MR1, MR2 when used on DC the reservoir smoothing capacitor C20 is connected to the 200V tapping on dropper R18. Thus, with the receiver operated from either AC or DC mains of the correct nominal voltage, the HT line voltage will be the same.

Reservoir smoothing capacitor C20 should be rated to handle 150 mA ripple.

LT of 7.5V for the series connected filaments of V1 to V4 is provided by an Ever Ready All-dry 31

battery, or, if the receiver is operated from the mains, from the rectified and smoothed HT supply through potential divider R17, R16. S5, which is ganged to S4, switches receiver filament line to appropriate source of supply.

R15 decoupled by C16 and R11 decoupled by C2 are current by-pass resistors to maintain correct voltage across each valve filament. S6, which is ganged to S4, S5 is mains ON/OFF switch. S4, S5, apart from switching HT and LT lines to battery or mains supply, also serve as ON/OFF switch when receiver is battery operated.

**Chassis removal.** Remove rear panel by inserting small coin in slot of quick release button at top and turning until slot is in vertical position.

Un-plug battery leads and remove batteries. Remove the four control knobs and unsolder the two leads to OP1 on LS and also earth wire to tag under LS fixing bolt.

Remove frame aerial and mains lead from cleat on side of cabinet. Undo the three Philips' screws situated one on either side of voltage adjusting panel bracket and one on bracket attached to right-hand side of chassis.

### TRIMMING INSTRUCTIONS

Apply signals as stated below	Tune Receiver to	Trim in Order stated for Max. Output
(1) Assemble chassis and frame aerial on bench in approximate position occupied when in cabinet and connect up to HT and LT batteries		
(2) 460 kc/s to g3 of V1 via .01 mF capacitor	—	Cores L6, L5, L4, L3
(3) 1.5 mc/s to frame AE via loop	200 metres	T3, T2
(4) 600 kc/s as above	500 metres	Core L7/8. Repeat (3) and (4)
(5) 300 kc/s as above	1000 metres	T4, T1
(6) 154 kc/s as above	1950 metres	Cores L9, L2. Repeat (5) and (6)
(7) Replace chassis in cabinet and using batteries and mains		check alignment,