

"TRADER" SERVICE SHEET  
**1727**

# ALBA 8002/S (Chassis Ty

Radiogram Incorporating B.S.R. UA25 Record Ch

**C**HASSIS type PW36 which is incorporated in Alba 8002/S radiogram employs four valves plus rectifier and incorporates twin two-stage audio channels for playing stereo disc recordings.

It covers the long, medium and short wavebands, with radio/gram and waveband selection by means of a press-button switch assembly. An internal ferrite rod aerial is fitted for l.w. and m.w.

reception, and a socket provides for the connection of an external aerial.

On radio, the identical audio channels are connected in parallel. The radiogram is fitted with a four-speed automatic record changer and is designed to oper-

ate from a.c. mains only of 200-250V 50 c/s.

**RECORD CHANGER**

The record changer fitted is a B.S.R. UA25 four-speed automatic with a dual sapphire crystal cartridge.

*Below: Circuit diagram of chassis type PW36 which is incorporated in the Alba 8002/S radiogram, and a drawing of the press-button switch contacts as they appear when viewed from the foil side of the printed circuit-panel. Two identical audio amplifier channels are featured which operate independently on gram for playing stereo recordings*

19	20	40,25	21,22
		8 7,16,17,9	

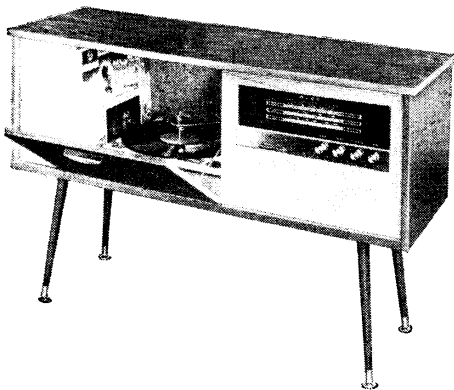

Appearance of the Alba 8002/S

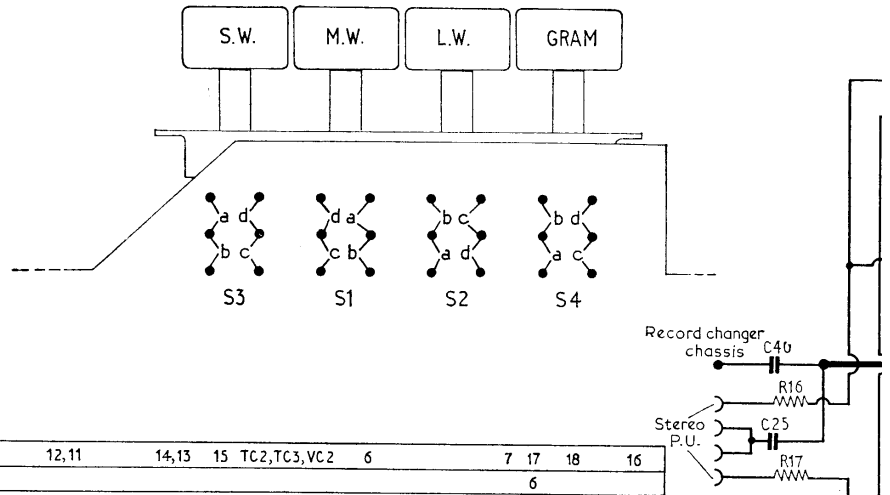

C	1	3	VC1	TC1,4	5	2	9,8	10	12,11	14,13	15	TC2,TC3,VC2	6	7	17	18	16	
R	1			2	3	5	4											

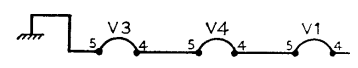
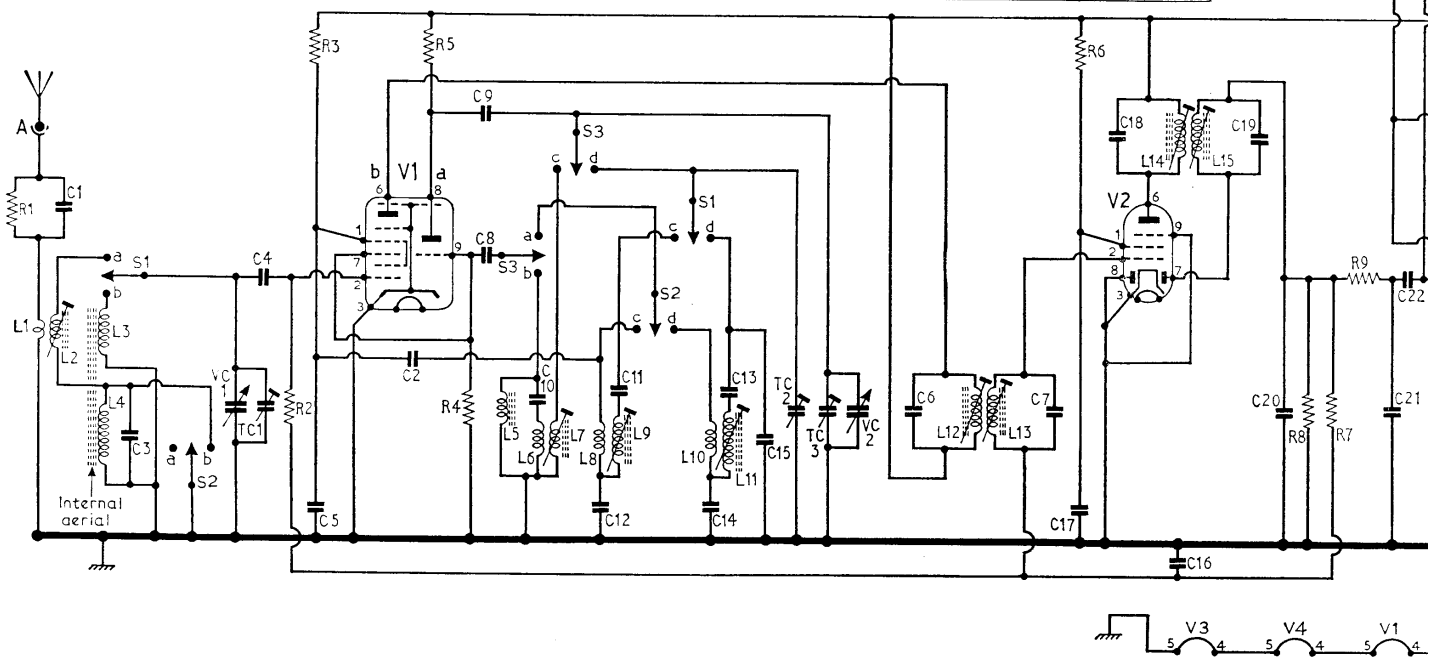

# Type PW36)

Record Changer

## CIRCUIT DESCRIPTION

The ferrite-rod aerial is coupled via m.w. coil L3 or l.w. coil L4 to the mixer grid of V1, via the wavechange switching and C4. The aerial coils are tuned by

VC1/TC1, and their respective fixed capacitors C2 and C3. a.g.c. is applied to the grid of the mixer via R2.

S.w. signals are fed in from an external aerial and taken via isolating network R1/C1 and input transformer L1/L2 to the wavechange switch and V1 grid.

The triode section of V1 is arranged as a parallel-fed local oscillator. On l.w., the tuned circuit comprises C13, L11, padder C14 and shunt capacitor C15. On m.w., C11, L9 and padder C12 are shunted by trimmer TC2. On s.w., the tuned winding is L7. On all bands, the main tuning is by VC2 with TC3.

The 470 kc/s i.f. signal produced in

V1 is coupled via IFT1 to the i.f. amplifier V2. The secondary of IFT2 (L15) is coupled to one of the V2 diodes, which operates as the detector and a.g.c. source, the other diode being taken to chassis.

The d.c. component of the demodulated signal, appearing across the detector load resistor R8, is applied via filter components R7/C16 as a.g.c. bias to the grid of the i.f. amplifier V2 and via R2 to the grid of the mixer V1.

The audio signals from the detector circuit are passed via the i.f. filter C20, R9, C21 and then through C22 to the

(Continued overleaf col. 1)

40,25	21,22	28	23,24	26,27	29,30,31,32,38,33,34,35,36	39	C
8	7,16,17,9	18,VR3,9,VR1,VR2,12,13,36,10,11,35,20,21,22,23,24,2,5,26,27,28,34,29,VR4,14,30,VR5,15,33,31,32					R

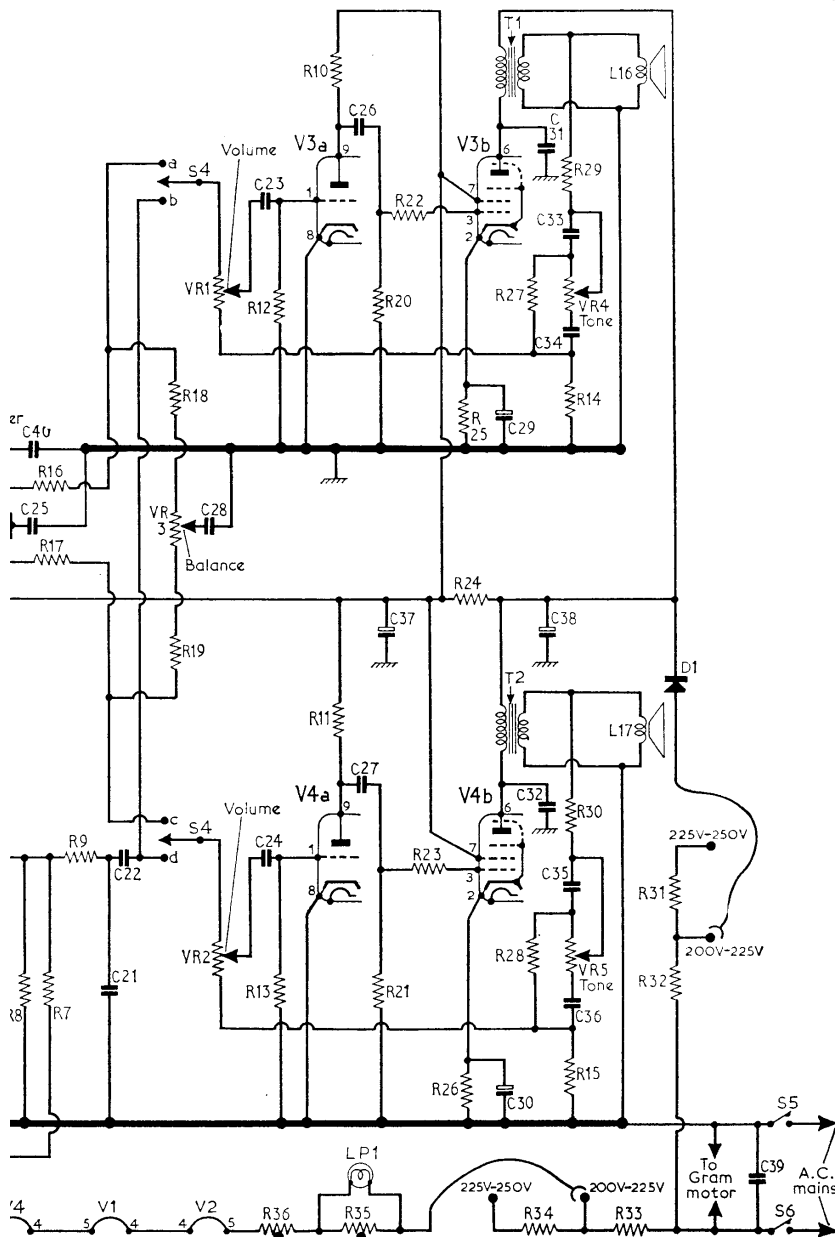

## Valve Table

Valve	Anode (V)	Screen (V)	Cathode (V)
V1 UCH81	a	100	—
	b	189	80
V2 UBF89	a	189	70
	b	80	—
V3 UCL82	a	228	189
	b	80	—
V4 UCL82	a	228	189
	b	—	14

## COMPONENT VALUES AND LOCATIONS

### Resistors

R1	2.2MΩ	†
R2	1MΩ	F4
R3	18kΩ	G4
R4	47kΩ	G5
R5	15kΩ	G5
R6	47kΩ	F4
R7	1MΩ	F4
R8	470kΩ	F4
R9	47kΩ	F4
R10	100kΩ	F5
R11	100kΩ	E4
R12	20MΩ	F4
R13	20MΩ	F4
R14	680Ω	F4
R15	680Ω	F3
R16	220kΩ	F3
R17	220kΩ	F3
R18	100kΩ	F3
R19	100kΩ	F3
R20	680kΩ	F4
R21	680kΩ	E4
R22	10kΩ	E4
R23	10kΩ	E4
R24	1.5kΩ	C1
R25	390Ω	E4
R26	390Ω	E4
R27	3.3kΩ	F4
R28	3.3kΩ	E4
R29	470Ω	C1
R30	470Ω	A1
R31	40Ω	B1
R32	20Ω	B1
R33	310Ω	B1
R34	300Ω	B1
R35	V1010	C2
R36	V1005	B2
VR1	500kΩ	E3
VR2	500kΩ	E4
VR3	5MΩ	F3
VR4	50kΩ	E3
VR5	50kΩ	E4

C18	—	F4
C19	—	F4
C20	200pF	F4
C21	100pF	F4
C22	1,000pF	F4
C23	5,000pF	F4
C24	5,000pF	E4
C25	0.01μF	—
C26	0.05μF	F4
C27	0.05μF	E4
C28	0.01μF	F3
C29	100μF	F4
C30	100μF	E4
C31	4,700pF	F4
C32	4,700pF	E5
C33	0.05μF	E4
C34	0.05μF	F3
C35	0.05μF	E4
C36	0.02μF	F4
C37	100μF	A1
C38	100μF	A1
C39	0.01μF	F4
C40	0.01μF	F4
TC1	30pF	D1
TC2	30pF	G4
TC3	30pF	D1
VC1	528pF	D1
VC2	528pF	D1

### Coils & Transformers

L1	—	G3
L2	—	G3
L3	—	F5
L4	—	G5
L5	—	G3
L6	—	G4
L7	—	G4
L8	—	G4
L9	—	G4
L10	—	G4
L11	—	G4
L12	—	F5
L13	—	F4
L14	—	F4
L15	—	F4
L16	—	—
L17	—	—
T1	—	C1
T2	—	B1

### Miscellaneous

D1	—	A2
LP1	24V 0.1A	C2
S1-S4	—	G3
S5, S6	—	E4

†On aerial socket.

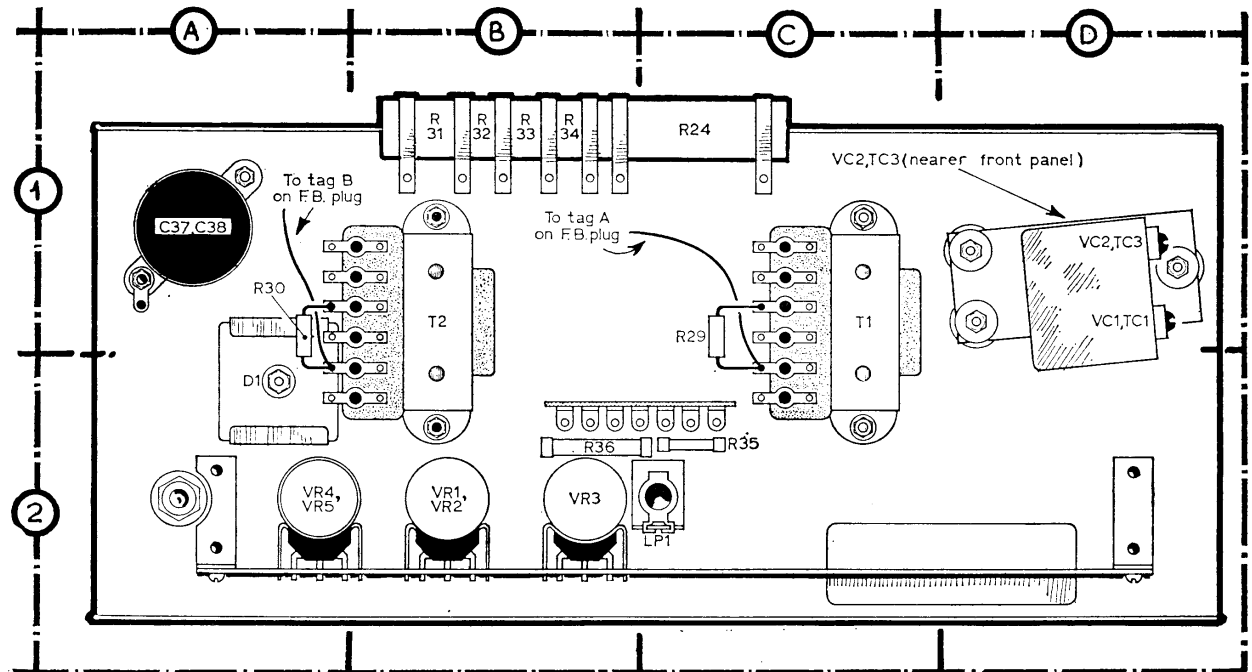

**Circuit Description—continued**  
gram/radio section of the wavechange switch.

The ganged switch sections S4a to S4d select either radio input (via C22) or gramophone input via the pick-up sockets. Two identical two-stage a.f. amplifiers are used and operated in parallel for radio and switched for separate use when playing records.

The outputs from the pick-up are fed via R16 and R17 to the amplifier input, these outputs being balanced by R18, R19 and VR3, the latter being the balance control. The pick-up circuit is isolated from chassis by C25 and R16/R17, and the motor plate by C40.

Input to the first stages is via the ganged volume controls VR1 and VR2. The outputs are fed in a conventional way to the respective output stages. Each output stage incorporates a frequency

*Above: Rear view of the control panel on which are mounted the tuning gang, left- and right-hand output transformers and mains input components. Controls VR1-VR5 have their spindles projecting through the control panel but are actually mounted on the printed circuit panel which is horizontal in this view, showing its rear edge only*

*Below: Scale drive assembly illustrated from the front with the tuning gang turned to maximum capacitance. Accurate adjustment of the cursor position can be carried out using the method described in col. 6 under "Drive Cord Replacement"*

selective negative feedback network. In V3b, the feed back circuit, taken from the secondary of the output transformer T1 and comprising R29, C33, R27, VR4, C34, is applied over R14 in the V3a grid circuit.

Negative feedback is thereby increased at low volume settings, giving a form of compensated volume control. A variable element in the feedback network (VR4) forms the manual tone control and is ganged with its counterpart in the V4b circuit (VR5).

The valve heaters are supplied by means of a series mains dropping chain. The scale lamp is also incorporated in this chain and is shunted by thermistor R35. This keeps the heater chain intact in the event of the scale lamp failing.

H.t. is derived from a metal rectifier D1 and is smoothed by C38. The h.t. line is further decoupled by R24 and C37.

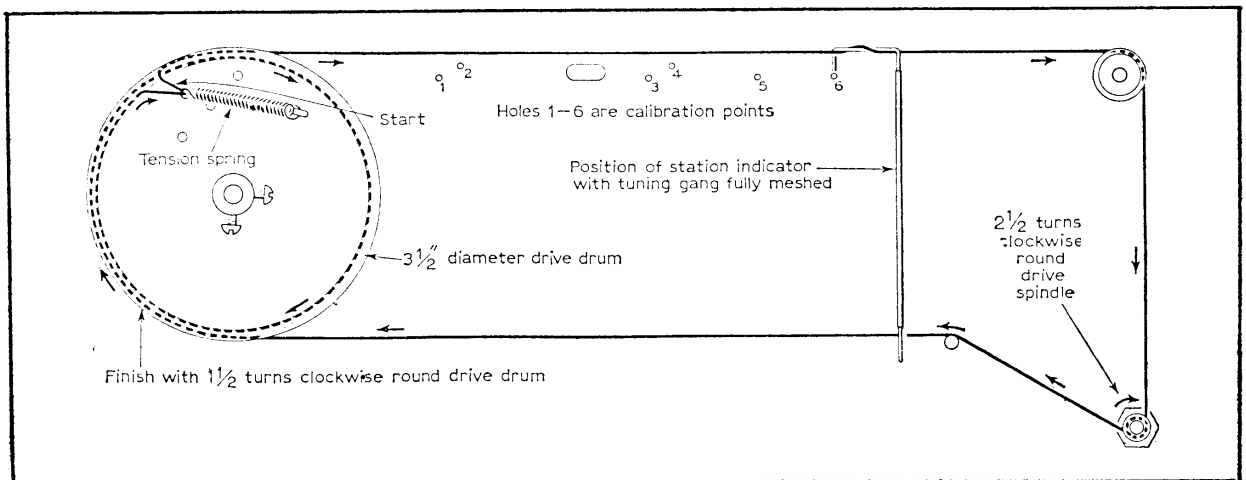

**VALVE ANALYSIS**

Valve voltages given in the table overleaf were taken from manufacturer's information. They were measured on a 20,000Ω/V meter under no signal conditions.

**CIRCUIT ALIGNMENT**

Before commencing alignment, check for output on both audio channels.

During alignment, the signal input should be reduced as the circuits come into line to prevent a.g.c. action. Where two tuning peaks occur the correct one is that with the core in the outer position.

**Equipment Required.**—An audio output meter and a 3Ω dummy load resistor; an a.m. signal generator; an r.f. coupling loop.

- 1.—Connect the audio output meter in place of one loudspeaker and the 3Ω resistor in place of the other. Turn the volume controls to maximum (fully clockwise) and the tone controls fully anti-clockwise. Connect the signal generator across the tuning capacitor aerial section VC1.
- 2.—Switch receiver to m.w. and fully mesh the tuning gang. Short-circuit the tuning gang oscillator section VC2.
- 3.—Feed in a 470kc/s 30 per cent modu-

lated signal and adjust the cores of L15, L14, L13 and L12 in that order, for maximum output. Repeat with reduced signal input for optimum results, then remove the short-circuit from VC2.

- 4.—Check that with the tuning gang fully meshed, the cursor lines up with calibration hole 6 as shown on the drive cord drawing opposite. (In this, and all subsequent references to calibration holes, the short leg of the cursor is used.)
- 5.—Connect the signal generator to the aerial socket via a dummy aerial. Switch receiver to s.w. and tune to 8Mc/s (hole 4). Feed in an 8Mc/s signal and adjust the cores of L7 and L2 for maximum output.
- 6.—Tune receiver to 16Mc/s, feed in a 16Mc/s signal and adjust TC3 and TC1 for maximum output.
- 7.—Connect the signal to the r.f. coupling loop and place the loop about 12in from the ferrite rod aerial, co-axial with the aerial windings. Switch receiver to m.w. and tune to 600kc/s (hole 5). Feed in a 600kc/s signal and adjust L9 and L3 (by sliding the former along the aerial rod) for maximum output.
- 8.—Tune receiver to 1,500kc/s (hole 1). Feed in a 1,500kc/s signal and adjust TC2 for maximum output.

- 9.—Switch receiver to l.w. and set the cursor to calibration hole 3 (200kc/s). By adjustment to the core of L11, tune in the B.B.C. Light Programme for maximum output. Then adjust L4 by sliding it along the ferrite rod, for maximum output.

**GENERAL NOTES**

**Switches.**—Waveband and gram switches S1-S4 are contained in a four-bank press-button unit which is mounted on the printed panel (see location reference G3). The individual switch contacts are shown in a separate illustration with the circuit diagram. On/off switches S5 and S6 are ganged with the tone controls.

**Drive Cord Replacement.**—A replacement drive cord should be routed as shown in the illustration at the foot of page 3, where the drive assembly is shown with the tuning gang fully meshed.

The position of the cursor on the cord can be adjusted by rotating the tuning gang until the cursor is over the slot between calibration holes 2 and 3, then inserting a screwdriver through the slot and adjusting the cursor as required, by sideways pressure of the screwdriver.

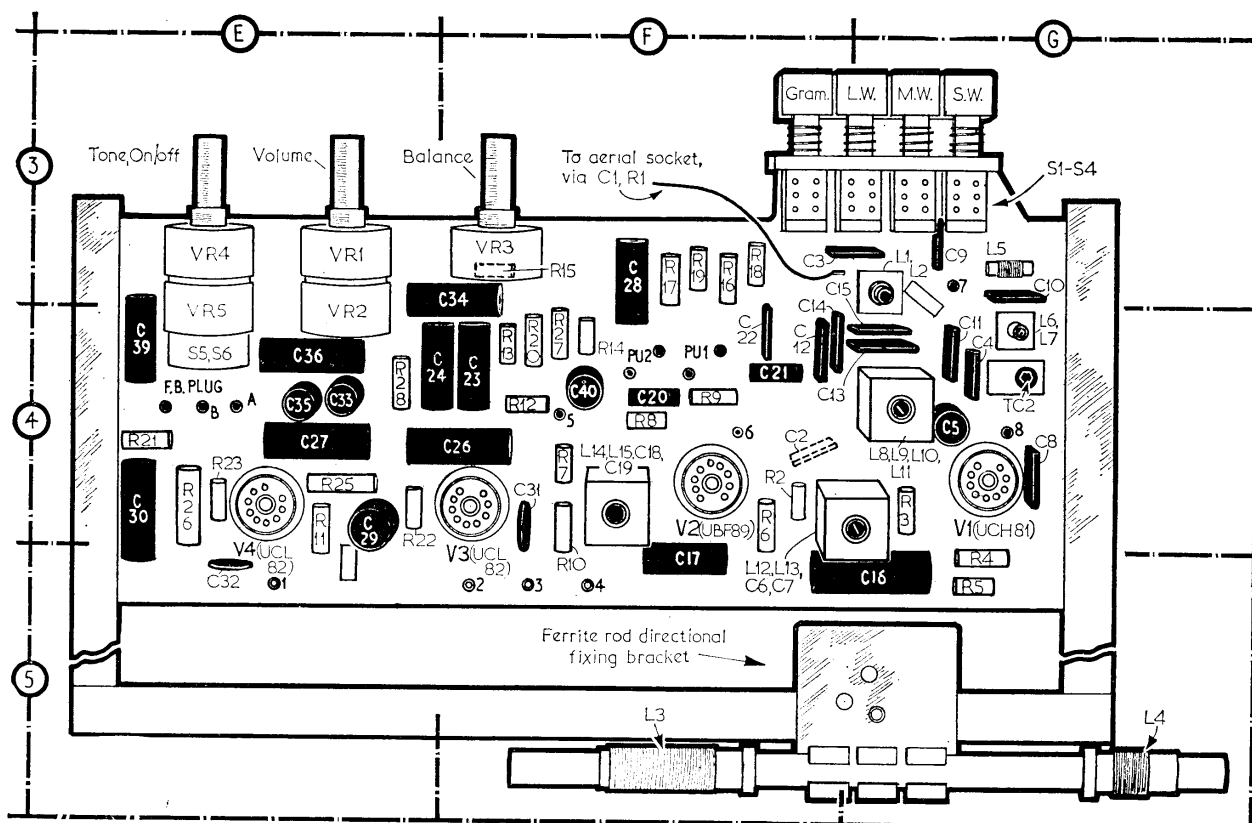

Component-side view of the printed circuit panel as seen when looking from above a dismantled chassis. The ferrite rod aerial bracket is provided with alternative fixing holes enabling the assembly to be partly orientated for optimum reception