

"TRADER" SERVICE SHEET
1825

DECCA TP90/A

A.M./F.M. Transistored Portable Radio Receiver

DECCA TP90/A a.m./f.m. transistor portable radio receiver covers m.w. (187.3-571m), l.w. (1150-2006m) and v.h.f. (87.5-101Mc/s).

It has an internal ferrite rod aerial for medium and long wavebands and a socket for an external aerial. For v.h.f. a telescopic aerial is fitted.

Nine transistors and five diodes are incorporated in a circuit dispersed over four printed circuit panels, made up as follows: V.h.f. tuner, mains chassis, preamplifier and audio. Plug and socket connections are used throughout with the exception, v.h.f. tuner to main chassis.

Controls consist of four press-buttons for waveband switching and on-off, and two knobs, one each for volume and tuning. All are situated on the top of the case.

Sound output is by a 5in round speaker and a socket is provided for an earphone or external loudspeaker of 15Ω impedance. The internal loudspeaker is muted when this socket is in use.

A socket for the connection of a tape recorder is also provided. This gives direct access to the top of the volume control via a blocking capacitor.

Power is supplied by a 9V (Ever-Ready PP9 type) battery.

The whole is contained in a vinyl covered case with carrying handle.

Battery replacement is facilitated by the removal of the case back after turning two plastic coin slotted screws one quarter turn.

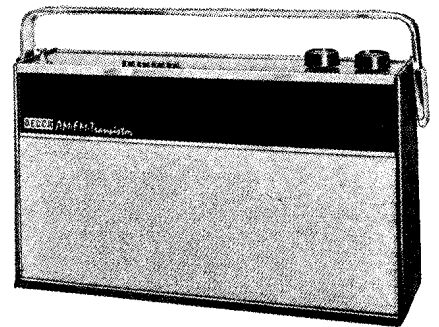

Three-quarter front view of the Decca TP90/A.

TRANSISTOR ANALYSIS

Voltages given in the table opposite were obtained from information supplied by the manufacturers. They were measured with a model 8 Avometer with respect to the negative line.

(Continued overleaf, col. 1)

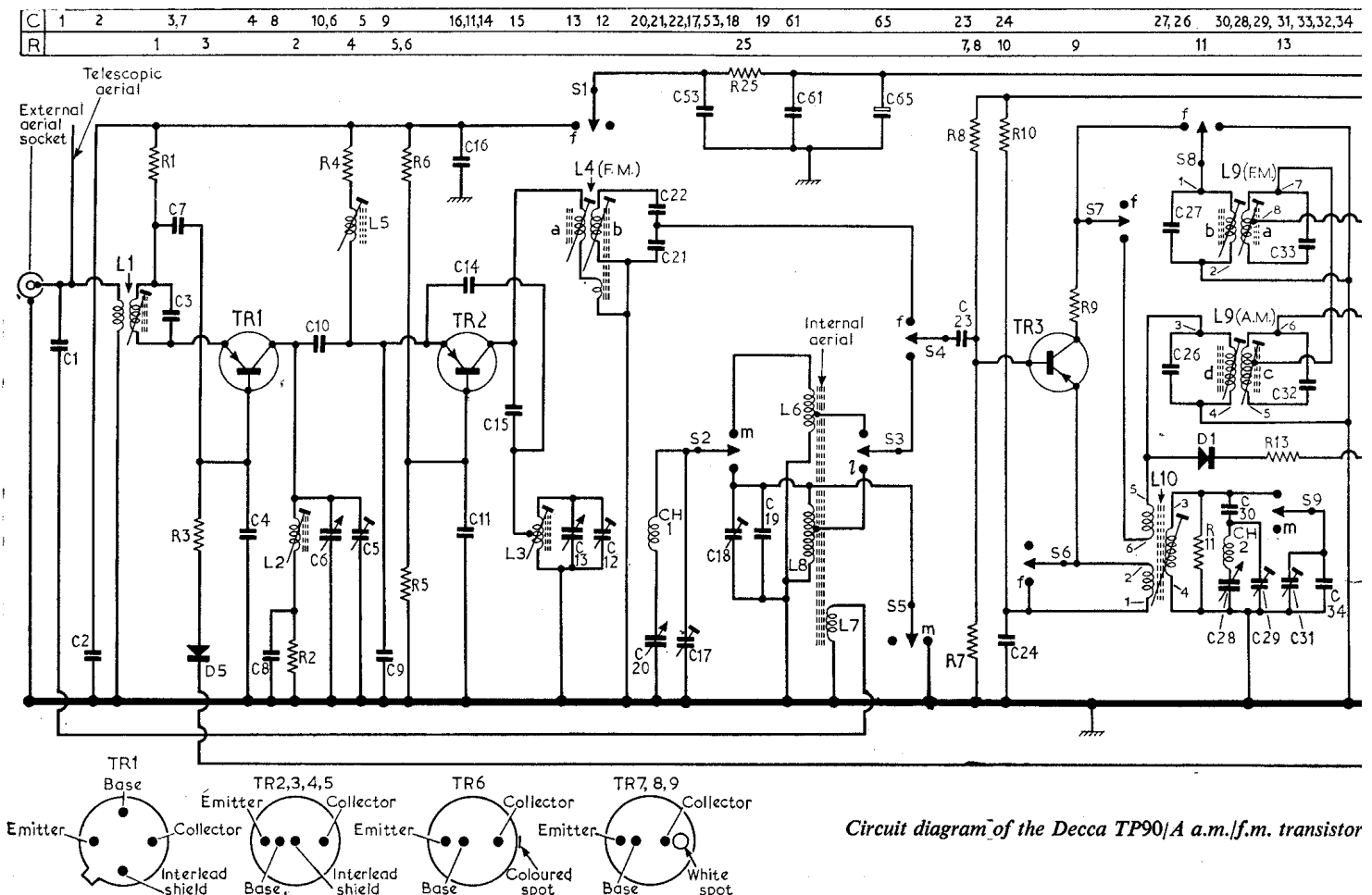

COMPONENT VALUES & LOCATIONS

Resistors			Capacitors			Coils and Transformers			Miscellaneous		
R1	330Ω	F4	C1	35pF	B1	L1	—	F4	D1	—	B2
R2	100Ω	F4	C2	0.01μF	F4	L2	—	F4	D2	—	B2
R3	1kΩ	F4	C3	47pF	F4	L3	—	F4	D3	—	B2
R4	3.3kΩ	F4	C4	1,000pF	F4	L4	—	F4	D4	—	B2
R5	10kΩ	F4	C5	20pF	F4	L5	—	F4	D5	—	C2
R6	10kΩ	F4	C6	—	F4	L6	—	B1	S1-S11	—	B1
R7	33kΩ	C1	C7	1,000pF	F4	L7	—	A1			
R8	6.8kΩ	B1	C8	1,000pF	F4						
R9	220Ω	C1	C9	560pF	F4						
R10	1kΩ	B1	C10	5.6pF	F4						
R11	270kΩ	B1	C11	1,000pF	F4						
R12	2.2kΩ	C2	C12	20pF	F4						
R13	680Ω	B2	C13	—	F4						
R14	56kΩ	B2	C14	8.2pF	F4						
R15	3.3kΩ	B2	C15	68pF	F4						
R16	330Ω	B2	C16	0.1μF	C1						
R17	470Ω	B2	C17	30pF	B1						
R18	1.5kΩ	B2	C18	30pF	B1						
R19	3.3kΩ	B2	C19	35pF	B1						
R20	10kΩ	B2	C20	238pF	F4						
R21	2.2kΩ	B2	C21	1,000pF	F4						
R22	220Ω	B2	C22	300pF	F4						
R23	470Ω	B2	C23	0.01μF	C1						
R24	47Ω	B2	C24	0.02μF	B1						
R25	47Ω	B1									
R26	390Ω	B2									
R27	680Ω	B2									
R28	82Ω	B2									
R29	6.8kΩ	B1									
R30	2.2MΩ	B2									
R31	6.8kΩ	B2									
R32	22kΩ	B2									
R33	1kΩ	B1									
R34	180kΩ	E3									
R35	10kΩ	E3									
R36	3.9kΩ	E3									
R37	1kΩ	E3									
R38	56kΩ	E3									
R39	18kΩ	E3									
R40	1kΩ	E3									
R41	100Ω	D3									
R42	47kΩ	E3									
R43	2.2kΩ	D3									
R44	100Ω	D3									
R45	2.2kΩ	D3									
R46	100Ω	D3									
R47	2.2Ω	D3									
R48	2.2Ω	D3									
VR1	5kΩ	B2									
VR2	25kΩ	A1									
C25	0.1μF	B1									
C26	560pF	C2									
C27	180pF	C2									
C28	238pF	F4									
C29	30pF	B1									
C30	186pF	B1									
C31	30pF	B1									
C32	560pF	C2									
C33	180pF	C2									
C34	150pF	B1									
C35	0.1μF	C2									
C36	0.1μF	B2									
C37	10μF	B2									
C38	1,500pF	B2									
C39	0.1μF	B2									
C40	300pF	B1									
C41	180pF	B1									
C42	1,000pF	B2									
C43	2μF	B2									
C44	300pF	B2									
C45	180pF	B2									
C46	0.1μF	B2									
C47	0.1μF	B2									
C48	1,000pF	B2									
C49	0.1μF	B2									
C50	300pF	B2									
C51	250pF	B2									
C52	0.1μF	B2									
C53	0.1μF	B1									
C54	50pF	B2									
C55	0.01μF	B2									
C56	1,000pF	B2									
C57	0.02μF	B2									
C58	10μF	B2									
C59	1,000pF	B2									
C60	0.22μF	B1									
C61	0.1μF	B1									
C62	0.04μF	B2									
C63	1,000pF	B2									
C64	0.022μF	B1									
C65	500μF	B2									
C66	0.22μF	B1									
C67	0.1μF	E3									
C68	10μF	E3									
C69	50μF	E3									
C70	100μF	E3									
C71	100μF	E3									
C72	500μF	E3									
C73	500μF	B1									
C74	50μF	E3									
C75	500μF	E3									

Transistor Table

Transistor	Emitter (V)	Base (V)	Collector (V)
TR1 AF180	5.2	4.5	0.1
TR2 AF115	3.0	2.5	—
TR3 AF114	4.5	4.0	0.1
TR4 AF114	6.0	5.5	1.5
TR5 AF114	5.9	5.5	0.5
TR6 OC71	7.3	6.7	0.3
TR7 OC81/D	7.7	7.3	1.2
TR8 OC81	4.6	4.2	0
TR9 OC81	9.0	6.9	4.6

25,36,39,38,35,41,40,42,43	46,45,44,47,37,48,49,50,51,52	55,54,56,59,57	58,64,63,66,60	62,67	68	70	69	71	72	73	74	75	C
14 15	12 18,17,16	20 21	23,22,24	28,26	19,27,VR1,33,29	30,31,32	VR2	35,34	37,36,38,39	40,42	41 46,45,44,43	48,47	R

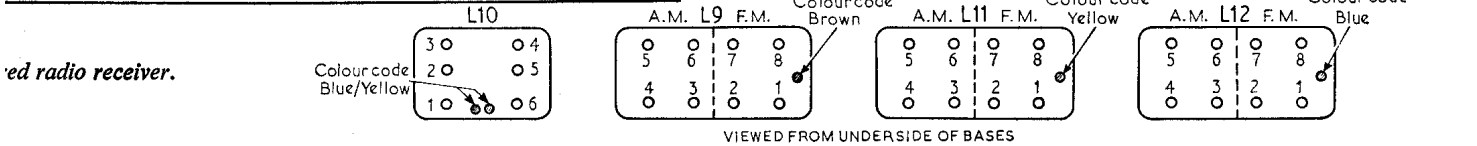
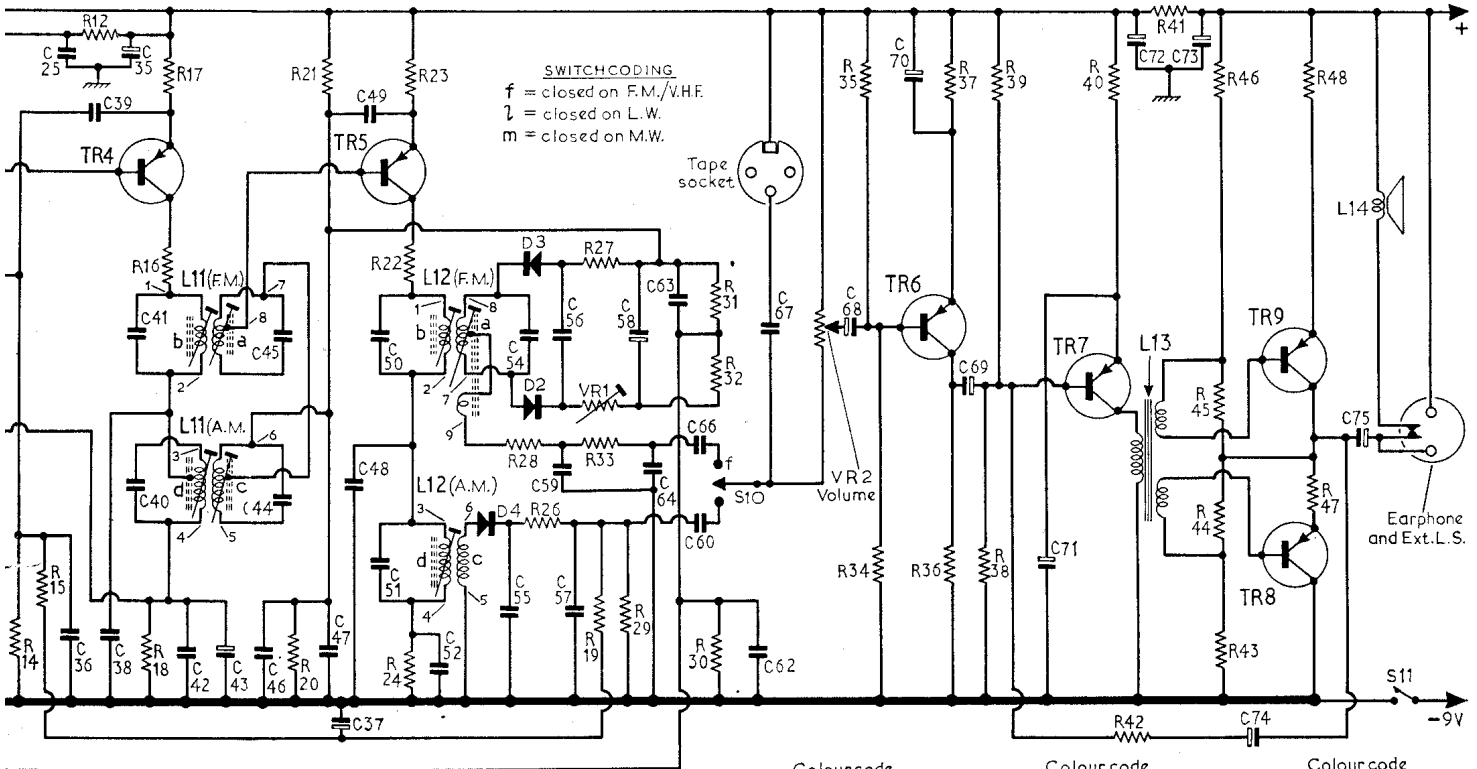

VIEWED FROM UNDERSIDE OF BASES

ed radio receiver.

Continued from overleaf—

CIRCUIT DESCRIPTION

With the receiver switched to v.h.f. S1 connects the v.h.f. tuner to the power supply. Signals received by either telescopic aerial, or via the external aerial socket are coupled by the broadly tuned r.f. transformer L1 into the emitter of earthed base amplifier TR1, then top capacity coupled by C10 into emitter of mixer/oscillator TR2.

Bandpass coupling components L2, C5, L5 and C9 are tuned over the band by C6, L5 also provides rejection of i.f. at 10.7Mc/s. C13 which is ganged with C6 is the variable capacitance providing oscillator tuning in conjunction with L3 and C12.

The i.f. component selected by transformer L4, is coupled by impedance matching capacitors C21, C22 via S4 and C23 into the base of TR3 the f.m./i.f. amplifier.

A short-circuit is placed across the a.m. oscillator feed back winding by the closure of S6, while S7 isolates the a.m./i.f. transformer L9c and d and coupling winding of L10 from TR3 collector. S8 in position f completes the signal path from TR3 collector via i.f. transformer L9a and b to TR4 base.

No more switching is required within the i.f. amplifier and after further amplification by TR4 and TR5 the signal is demodulated by a ratio-detector incorporating diodes D2 and D3. After demodulation the a.f. component is fed via the de-emphasis and i.f. filter network R28, C59, R33 and C64 to S10 for connection to the a.f. amplifier.

A potential divider consisting of the

series connected resistors R31 and R32 is in parallel with C58, and is designed to provide a suitable proportion of the d.c. voltage developed across C58 for use as a.g.c. bias. The bias thus derived is then applied via diode D5 to the base of the r.f. amplifier TR1 thereby controlling the gain.

When switched for m.w. or l.w. operation S1 and S6 open. S4, S7, S8 and S10 make at a.m.

Signals induced into the ferrite rod aerial windings are tuned by L6, C17 and C20 for m.w. and L8, C17, C18, C19 and C20 for l.w. Switches S2, S3 and S8 provide the necessary connections for the waveband in use. The signal is conducted via S4 and C23 into the base of the a.m. mixer/oscillator TR3. Oscillator tuning for m.w. is obtained from the tuned circuit comprising L10, C29, C30 and tuning capacitor C28. S9 includes C31 and C34 for l.w. tuning.

After mixing in TR3 the signal component centered at 472kc/s is selected and coupled by i.f. transformer L9d and e into the base of TR4. Amplitude limiting in TR3 collector circuit is provided by the damping diode D1.

The signal after amplification by TR4 is coupled by L11c and d into TR5 for further amplification then fed via L12c and d into the series diode demodulator D4. C55, R26 and C57 filter out the residual i.f. component and R29 is the detector load. A.g.c. applied to TR4 base is derived from the d.c. component present in the rectified signal and filtered by R19 and C37.

Audio frequencies from either system are selected by S10 and fed to the volume control VR2. TR6 the first a.f. amplifier

is r/c coupled into TR7, which has in its collector load the phase splitting transformer L13, by which means the signal is fed in anti-phase into the bases of the single ended Class B power amplifier TR8 and TR9. Energy at a.f. from the junction of R47 and TR9 collector is a.c. coupled by C75 into the loudspeaker load L14. Non-selective negative feedback is applied between TR9 collector and TR7 base via C74 and R42.

CIRCUIT ALIGNMENT

Equipment Required.—An f.m./a.m. signal generator with the following outputs. 10.7Mc/s, 88Mc/s, 100Mc/s, all with 22kc/s deviation. 150kc/s—2Mc/s amplitude modulated 30 per cent; An a.c. voltmeter, 300mV f.s.d. One 1kΩ resistor.

Because the scale is attached to the case, it is advisable to make a temporary scale, with calibration marks indicated, before attempting r.f. alignment. This calibrator could then be clipped to the card, backing the cursor.

Remove the chassis from the case. Instructions for this will be found under "General Notes".

Set the voltmeter to the 300mV a.c. range and connect it across the loudspeaker coil. Turn the volume control to maximum. To avoid a.g.c. action, the input signal level should be kept as low as possible consistent with a reasonable indication on the output meter.

- 1.—Switch on signal generator and allow 15 minutes to warm up.
- 2.—Turn tuning capacitor to maximum capacitance switch radio to f.m. and

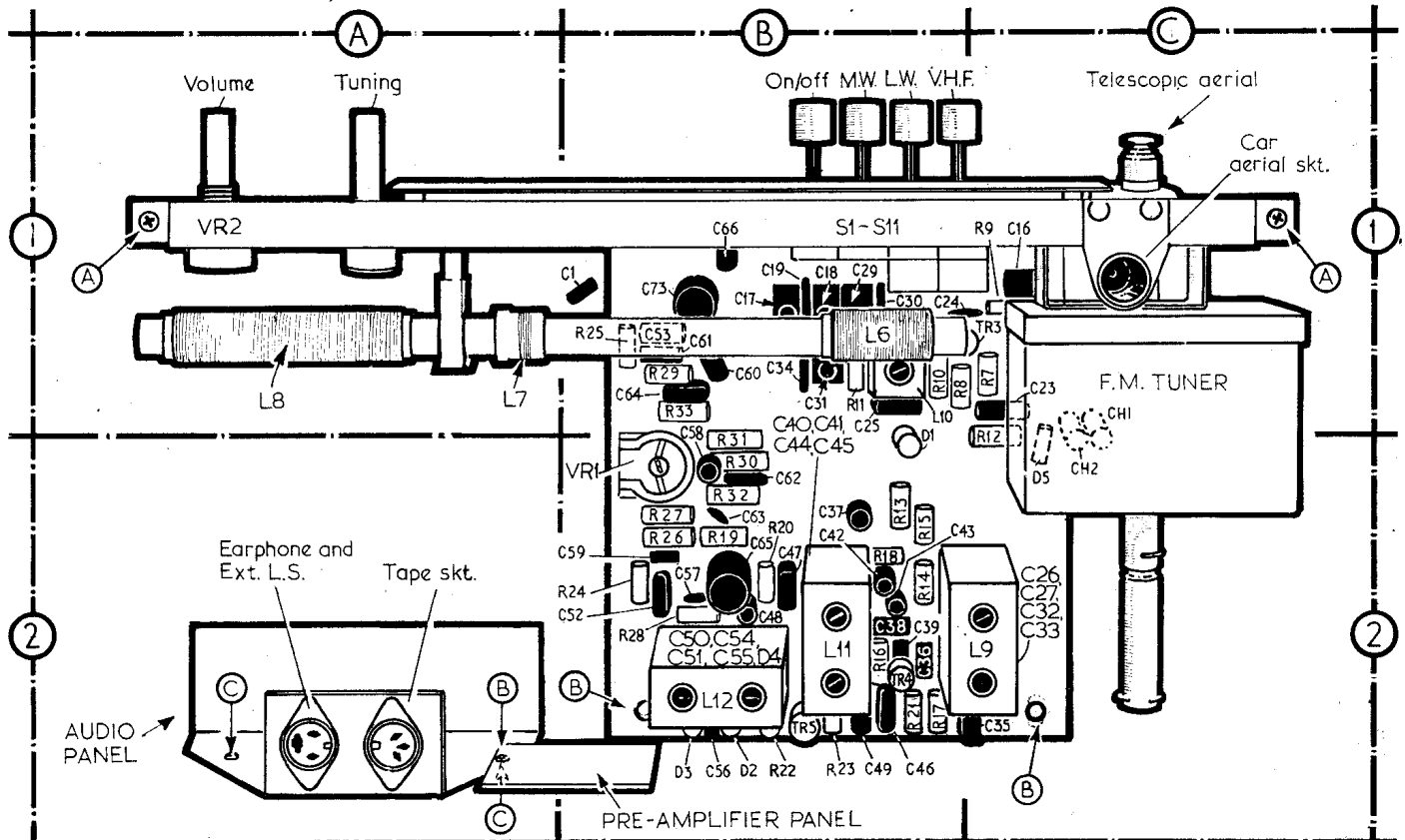

Rear view of receiver with the back cover removed, showing component locations on the main chassis.

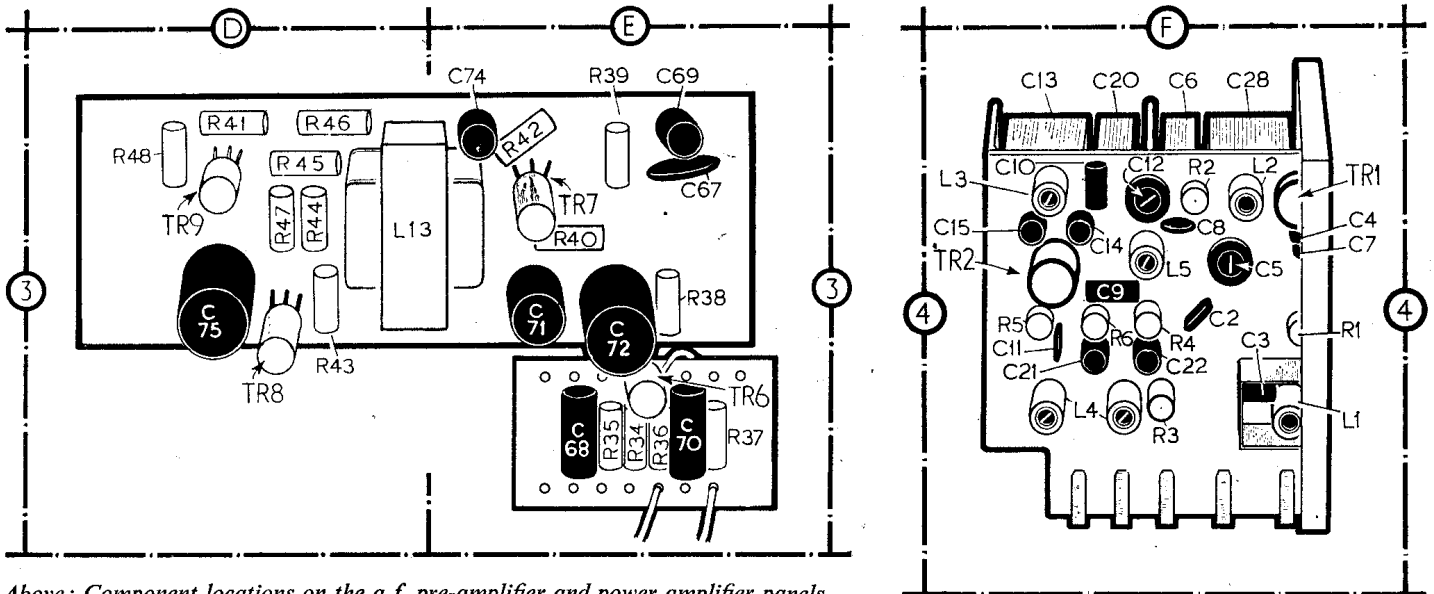

Above: Component locations on the a.f. pre-amplifier and power amplifier panels. Right: F.m. tuner with screen removed showing location of components.

connect f.m. signal generator output lead to junction of S4 and C23, the other lead should be connected to chassis on the printed panel.

- 3.—Feed in a 10.7Mc/s (22kc/s deviation) signal. Adjust L9a and b, L11a and b, L12a and b for maximum output. Repeat until no further increase can be obtained.
- 4.—Connect signal generator to aerial input terminals. Increase signal. Adjust L4a and b for maximum output.
- 5.—Switch signal generator to a.m. position, feed in 10.7Mc/s a.m. 30 per cent modulated signal. Adjust VR1 for minimum output.
- 6.—Repeat operations 3, 4 and 5.
- 7.—Check that the cursor lines up with calibration marks at the low frequency end of tuning scale with tuning gang fully closed.
- 8.—Tune receiver to 88Mc/s as marked on scale. Switch signal generator to f.m. Feed in an 88Mc/s (22kc/s deviation) signal via aerial socket. Adjust L2 and L3 for maximum output.
- 9.—Feed in 100Mc/s (22kc/s deviation) signal, tune receiver to 100Mc/s as marked on scale. Adjust C12 and C5 for maximum output. Tune to 95Mc/s as marked on scale. Maintain input at 100Mc/s. Adjust L1 and L5 for maximum output.
- 10.—Set signal generator to a.m. Switch radio to m.w. disconnect at L6, the lead connecting L6 to S3. Connect signal generator between the free end of lead and chassis. Rotate tuning capacitor to maximum capacitance.
- 11.—Feed in a 472kc/s signal. Adjust L9c and d, L11c and d, L12d, for maximum output. Repeat as necessary.
- 12.—Disconnect signal generator and reconnect lead to L6. Connect signal

generator output via the 1kΩ resistor to aerial socket, the other lead to chassis.

- 13.—Tune receiver to 500 metres as marked on scale. Feed in a 600kc/s signal. Adjust L10 for maximum output.
- 14.—Position L6 on ferrite rod for maximum output.
- 15.—Tune receiver to 200 metres as marked on scale. Feed in a 1.5Mc/s signal. Adjust C29 and C17 for maximum output.
- 16.—Repeat operations 13-15 until no further improvement is effected.
- 17.—Switch receiver to l.w. Tune to 1,765 metres as marked on scale. Feed in a 170kc/s signal. Adjust position of L8 on ferrite rod, and C31 for maximum output.
- 18.—Tune receiver to 1,250 metres as marked on scale. Feed in a 240kc/s signal. Adjust C18 for maximum output.
- 19.—Repeat operations 17 and 18 until no further improvement is effected.

GENERAL NOTES

Dismantling.—Remove the case back after turning the two plastics coin slotted screws one quarter turn. Remove the battery. Unscrew two Phillips head screws "A", three 4BA nuts "B", and two Phillips head 4BA screws "C". (See main chassis illustration). Disconnect the loudspeaker leads. Withdraw chassis to the extent of the telescopic aerial lead, and unsolder this

Drive cord assembly viewed from above, with tuning gang at maximum capacitance.

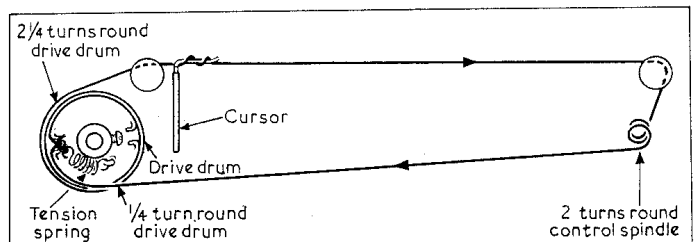

lead at the aerial end. The main chassis and subsidiary panels can now be removed.

Audio sockets.—A suitable plug for the earphone socket is a McMurdo TRP3 two pin D.I.N. plug switch. A normal three-pin D.I.N. plug is used for tape recorder connection. Note: Pin 2 is the signal connection.

Press Button Switch Assembly.—The switch diagram below is drawn with the connecting tags as they appear when

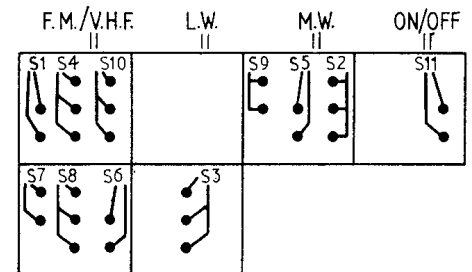

looking at the chassis from the front (printed circuit side) of the panel. The centre tag of each trio is the common connection which makes contact with the remote tag when the button is depressed and with the near tag when the button is released.