

# EKCO A104 & U109

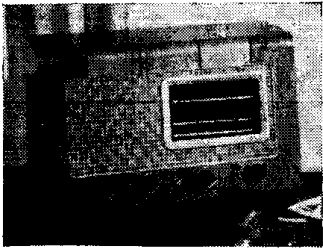

Five-valve three-waveband superhet fitted with sockets for external aerial, earth, high-resistance pickup and low-impedance extension speaker. Figured walnut veneered cabinet. Suitable for 200 to 250V, 50-100c/s AC mains. Made by E. K. Cole, Ltd., Somerton Works, Arterial Road, Southend-on-Sea.

AERIAL signal is fed to series connected aerial coupling coils L2 (SW), L4 (MW), L6 (LW), and to IF filter circuit L1, C1. C2 (SW), and C3 (MW), are bypass capacitors. The grid coils L3 (SW), L5 (MW), L7 (LW), which are trimmed by T1, T2, and T3, C4 respectively, are switched by S1 to aerial tuning capacitor VC1 and coupled by C6 to triode-hexode frequency changer V1. S2 shorts the unwanted aerial coils.

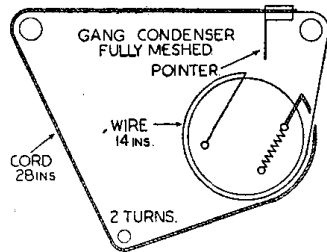
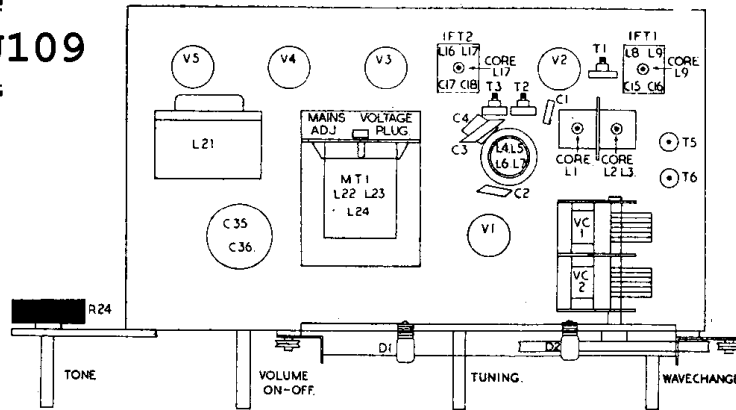

## RESISTORS

R	Ohms	Watts
1 ...	27K	...
2 ...	470K	...
3 ...	33K	...
4 ...	330	...
5 ...	47K	...
6 ...	33K	...
7 ...	47	...
8 ...	68K	...
9 ...	330	...
10 ...	2.2K	...
11 ...	47K	...
12 ...	1M Potr. with Switch	...
13 ...	680K	...
14 ...	1M	...
15 ...	1M	...
16 ...	4.7K	...
17 ...	100K	...
18 ...	15K	...
19 ...	470K	...
20 ...	470K	...
21 ...	47K	...
22 ...	680K	...
23 ...	120	...
24 ...	500K Potentiometer	...
25 ...	12K	...

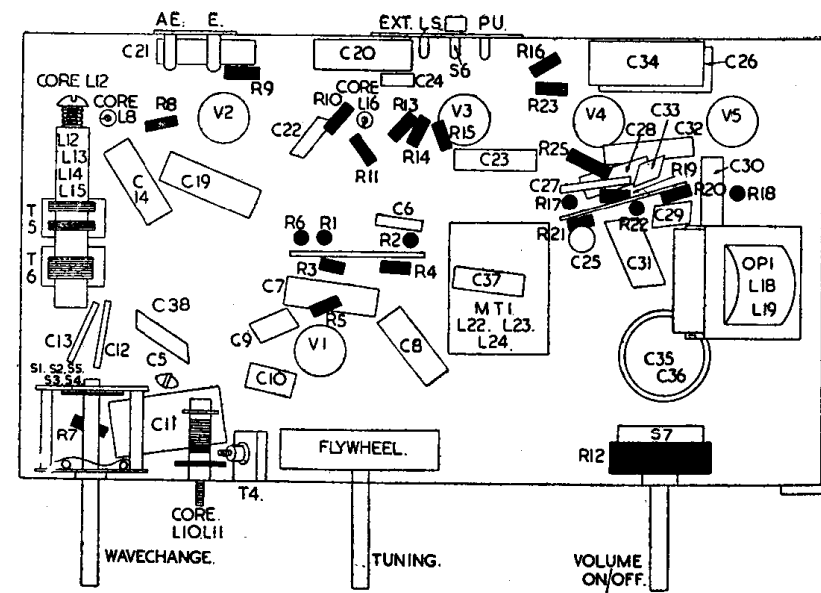

R	7	8	9	10	11	13, 14	15	16, 25, 26	17	18		
C	13	12	14	5, 21	19	9, 10	22, 20, 24	6	23	27	34, 28, 32, 26, 30	18
L	12, 13	14, 15	10, 11					22, 23, 24			18, 19	

## INDUCTORS

L	Ohms
1 ...	60
2 ...	.25
3 ...	Very low
4 ...	18
5 ...	4
6 ...	45
7 ...	28
8 ...	32
9 ...	32
10 ...	Very low
11 ...	4
12 ...	3
13 ...	1.5
14 ...	6
15 ...	2
16 ...	15
17 ...	15
18 ...	350
19 ...	.5
20 ...	2.5
21 ...	350
22 ...	115 Tapped 80
23 ...	8
24 ...	40

## CAPACITORS

C	Capacity	Type
1 ...	100pF Silver Mica	
2 ...	220pF Silver Mica	
3 ...	680pF Silver Mica	
4 ...	56pF Silver Mica	
5 ...	1pF Disc	
6 ...	300pF Silver Mica	
7 ...	.1 Tubular 350V	
8 ...	.1 Tubular 350V	
9 ...	47pF Silver Mica	
10 ...	.001 Mica	
11 ...	4700pF Silver Mica	
12 ...	630pF Silver Mica	
13 ...	420pF Silver Mica	
14 ...	.1 Tubular 350V	
15 ...	56pF Silver Mica	
16 ...	56pF Silver Mica	
17 ...	100pF Silver Mica	
18 ...	100pF Silver Mica	
19 ...	.1 Tubular 350V	
20 ...	.1 Tubular 350V	
21 ...	.1 Tubular 350V	
22 ...	50pF Silver Mica	
23 ...	.005 Tubular 350V	
24 ...	15pF Tubular Ceramic	
25 ...	.005 Tubular 1000V	
26 ...	25 Electrolytic 25V	
27 ...	1600pF Silver Mica	
28 ...	.01 Tubular 500V	
29 ...	82pF Silver Mica	
30 ...	.0025 Tubular 500V	
31 ...	820pF Silver Mica	
32 ...	.005 Tubular 500V	
33 ...	82pF Silver Mica	
34 ...	2 Electrolytic 350V	
35 ...	32 Electrolytic 350V	
36 ...	32 Electrolytic 350V	
37 ...	.0025 Tubular 600V AC	

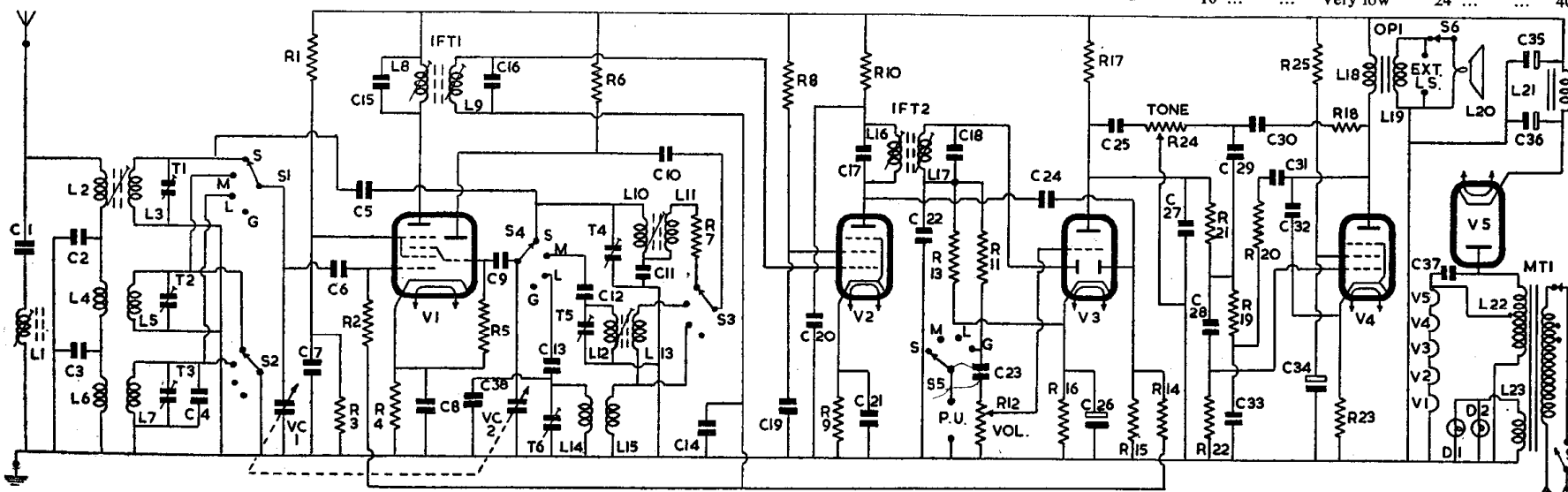
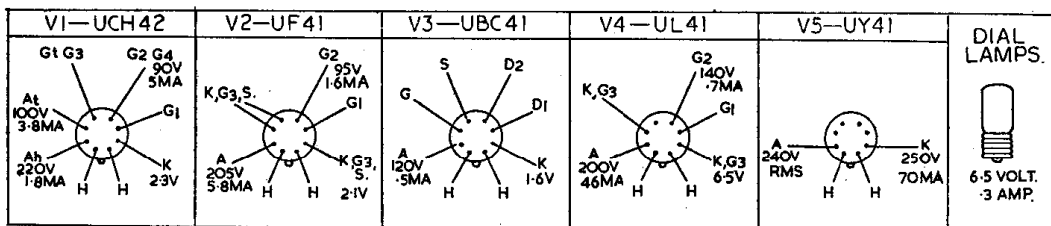

A VC decoupled by R14, C14 is fed by R2 to g1 of V1.

Oscillator is connected in a tuned-grid shunted circuit. The grid coils L10 (SW), L12 (MW), L14 (LW), which are trimmed by T4, T5, T6, and padded by C11, C12, C13, respectively, are switched by S4 to oscillator tuning capacitor VC2 and coupled by C9 to grid of triode oscillator section of V1. Automatic bias for grid is developed on C9 with R5 as leak resistor.

C5, connected between the SW aerial and oscillator tuned coils, is a small neutralising capacitor.

Anode reaction voltages are developed inductively on L11 (SW), L13 (MW), L15 (LW), and are switched by S3, through coupling capacitor C10, to oscillator anode of V1. R6 is its anode load and R7 a series limiter for SW band.

IF amplifier operates at a frequency of 460kc/s. Secondary L9, C16, of IFT1 feeds signal and AVC voltages to g1 of IF amplifier V2. AVC decoupling is given by R14, C14.

Cathode bias is provided by R9 and decoupled by C21. Screen (g2) voltage is obtained from R8 and decoupled by C19. Suppressor grid (g3) is internally strapped to the cathode. Primary L16, C17, of IFT2 are in the anode circuit, the HT supply to which is decoupled by R10, C20.

Signal rectifier.—Secondary L17, C18 of IFT2 couples signal from anode of IF amplifier V2 to one diode of V3. R13 is its load resistor and C22 a filter capacitor.

AVC.—C24 feeds signal from anode of IF amplifier V2 to second diode of V3. R15 is its load and R14 with C14 decouples the AVC feed to V1 and V2. The cathode bias developed across R16, C26 provides AVC delay voltage.

AF amplifier.—The rectified signal developed across signal diode load R13 is fed through R11, C23, to volume control R12 and thence to grid of triode section of V3.

Cathode bias is provided by R16 decoupled by C26. R17 is the anode load and C27 a bypass capacitor.

Pickup.—Sockets are provided for connection of high-resistance pickup. Signal from pickup is switched by S5 through C23 to top of volume control R12. S5 is ganged to the wavelength switches S1 to S3, which in the gram. position, remove aerial and oscillator tuned circuits from frequency-changer V1 to prevent radio break-through.

Output stage.—The signal at anode of V3 is fed through R21 and C28 to g1 of pentode output valve V4, of which R22 is the grid resistor. Cathode bias is provided by undecoupled resistor R23.

Screen (g2) voltage is obtained from R25 and decoupled by C34. Suppressor grid (g3) is internally connected to cathode. Primary L18 of output matching transformer OPI is the anode circuit. C32 gives fixed tone correction.

Secondary L19 of OPI feeds signal to an 8in. PM speaker L20. Sockets are fitted on L19 for connection of a low-impedance extension speaker. S6 located on the extension socket panel at the rear of chassis enables the internal speaker to be silenced when an extension is used.

Negative Feedback and adjustable tone control circuit, consisting of C25, C29, C30, C31, C33, R18, R19, R20, R21, R24, is connected between anodes of V3, V4.

HT is provided by an indirectly heated half-wave rectifier V5. Its anode voltage is obtained from secondary L22 of mains input transformer MT1. Choke-capacity smoothing is given by L21, C35, C36. Reservoir capacitor C36 should have a ripple current rating in excess of 150 mA. C37 eliminates modulation hum.

Heaters of V1 to V5 are connected in series and obtain their current of 100mA from tapping on secondary L22 of MT1.

Dial lights are supplied from a separate secondary winding L23. Primary L24 of MT1 is tapped for inputs of 200-210, 220-230, 240-250V, 50-100 c/s. S7, which is ganged to the volume control spindle, is the ON/OFF switch.

Chassis removal.—Remove the four push-on type control knobs and rear panel of cabinet. Remove the four chassis bolts on underside of cabinet and the two wood screws securing top of dial assembly to cabinet.

Chassis can now be withdrawn as far as LS leads will permit. Speaker can be removed by loosening nuts holding clamping bars on edge of LS chassis.

MODEL U109

Model U 109 which is the AC-DC version of the A104 differs from the circuit printed overleaf as follows:

Aerial is coupled to L2 through a .0025mF isolating capacitor.

PU sockets are isolated by a .05mF capacitor on the earthy side and a .01mF on the live side.

Secondary L19 and LS earthed to chassis through .1 mF capacitor.

Heaters of V1 to V5 obtain their current from the mains through a 1,230 ohms resistor tapped at 150 and 300 ohms for voltage adjustment.

Dial lights connected in series across a 3,000 ohms (cold resistance) in the mains lead to chassis.

Rectifier anode voltage obtained from mains through a 130-ohm limiter resistor.

Mains input fitted with a .1mF bypass capacitor. S7 is a double pole ON/OFF switch.

TRIMMING INSTRUCTIONS

Apply signal as stated below	Tune receiver to	Trim in order stated for max. output
(1) 460 kc/s to g1 of V1 VIA .1 mF	MW Band gang at max.	Cores of L17, L16, L9, L8
(2) With gang at max. setting adjust dial pointer to coincide with datum mark at low frequency end of scale.		
(3) 1.3 mc/s to AE socket via dummy aerial	250 metres	T5, T2
(4) 800 kc/s as above ...	375 metres	Core L12
(5) 600 kc/s as above ...	500 metres	Check calibration and repeat (3), (4) and (5) if necessary
(6) 250 kc/s as above ...	1200 metres	T6, T3
(7) 150 kc/s as above ...	2000 metres	Check calibration
(8) 6.5 mc/s as above ...	46.15 metres	Core L10, L3
(9) 15 mc/s as above ...	20 metres	T4, T1. Repeat (8) and (9)
(10) 460 kc/s as above...	—	Core L1 for minimum

SERVICE CASEBOOK

This popular page is contributed by readers. If you haven't had a go yet, what about that "sticky one" you solved yesterday?

EKCO TS46

I RECENTLY had a TV set to repair which had a rather unusual fault. It was an Ekco TS46. After running for a few minutes the picture seemed to move to and from the viewer, the size and focus of the picture varying in a regular pulsating rhythm. Line and frame scans altered together and so it was obvious that either the HT to timebases or the EHT was varying.

HT being found normal, the HF oscillator and HV rectifier became suspect. The oscillator seemed stable but it was noted that the U22 rectifier had a slight blue glow which varied with the picture movement. The valve was replaced and the fault cleared.—L. REEVE, Romford.

IF TRIMMER OC

A FOUR-VALVE battery portable was brought in with the complaint that reception was weak until the top cap of one of the HF valves was touched with the aerial, when volume became quite good.

Being pressed for time a new valve was substituted with no effect; then it dawned on me that the receiver was a superhet and not a straight, and that the valve in question was the IF amplifier.

The trouble was found to be due to the picofarad condenser shunted across the secondary of the first IFT having come unsoldered at one end. The application of the aerial increased volume, not by applying an extra EMF but by adding extra capacity to the IFT secondary circuit and thus bringing it more in tune.—G. R. WILDING, Liverpool.

AN ELUSIVE CRACKLE

A PRE-WAR Ferranti AC superhet crackled on MW but was OK on LW and SW. Reception otherwise was perfect, and the lower down the waveband the worse the crackle became. Round about 450 metres the crackle was hardly noticeable, but at 250 metres was unbearable.

Removing the aerial did not affect it, neither did changing the VHT4 frequency changer, cleaning the tuning condenser earthing springs, or cleaning the wave change switch.

Eventually a badly soldered connection to the noise suppressor toggle switch on the back of the chassis was observed, remade, and the fault disappeared. But why it mainly affected only the lower half of the MW remains a puzzle.—G.R. WILDING, Liverpool.

PHILCO 444

WITH a Philco model the customer's complaint was that the set had failed to function, and emitted an unpleasant howl when it was tuned towards the low frequency end of the scale.

The usual voltage checks were applied, valves checked for mutual conductance, and by substitution, also decoupling condensers and all found to be in reasonable condition. The IFT's, which had drifted considerably, were readjusted to the recommended frequency.

The set remained unstable and modulated RF signals applied to the AE sockets manifested

themselves at the speaker only in a very weak and intermittent form. Calibration of the scale was very much out, a 1mc/s signal appearing at approximately the 1.25mc/s point. Coil resistance (DC) was then checked on both aerial and oscillator coils and found to be of the right order. The AVC line was suspected and removed but with no effect.

At this stage, as things were becoming a little perplexing, it was noted that a small capacitance was shorting. It was constructed of a pair of short covered wires used to capacitively couple the stator vanes of the aerial and oscillator sections of the two-gang condenser. This fault was put right and the set then found to be in good condition again.—C. H. WINDSOR, Enfield.

EVER READY PORTABLES

SEVERAL Ever Ready battery portables have come in for repair recently with the symptom of performance a little below standard, and distorting easily with the volume turned at all high.

The trouble was found to be due to the  $\frac{1}{2}$ W 2.2 meg. resistor in the screen feed of the diode pentode DAF91. These resistors seem prone to increase their value to upwards of 10 meg.

As the screen current is very small, the voltage when correct is only measurable on a high resistance voltmeter, and this should be borne in mind when checking.—E. J. BENNETT, Shepley.

EFFECT OF FAULTY CONTACT

A 3HP three-phase squirrel cage motor geared to a small mill would stall after a long period of satisfactory service. Starter connections and contacts were in order and no fuses had melted.

Finally, it was found that the difficulty was experienced only when a nearby 15hp three-phase motor was in use. As the motors were supplied through the same distribution fuse box, the circuit was checked carefully and a badly burnt contact and blade were located in the three-pole combined switch and fuse box through which the distribution box was supplied.

There had been a considerable volt drop at the faulty contact when this was loaded by the current for the two motors. This drop was sufficient to cause unbalanced voltages on the three-phase lines to such a degree that the small motor stalled on peak loads. It was rather surprising that the 15hp motor ran quite well; this was probably due to the fact that this machine was not overloaded.—J.L.W.

