

FERGUSON**MODEL 384 U**

Schedules A & B Production

PRELIMINARY SERVICE DATA**SPECIFICATION****GENERAL**

A 6-valve (including tuning indicator) AM/FM receiver with piano-key waverange switching and separate AM and FM tuning controls. Internal aerials are fitted as well as sockets for external aerials and earth connection. Switched pick-up sockets and external loudspeaker sockets are also provided.

MAINS SUPPLY

200-250 Volts AC or DC, 50-60 c/s AC. Power consumption approximately 50 Watts.

WAVEBAND COVERAGE

Long Wave	- 1160—1940
	Metres
Medium Wave	- 188—545
	Metres
VHF/FM	- 88—101
	Mc/s

CABINET

Moulded plastic table model, 17 $\frac{3}{4}$ in. wide x 13 in. high x 6 $\frac{3}{4}$ in. deep.

DRIVE CORD REPLACEMENT**A.M. TUNING**

Allow 4ft. 3in. of nylon braided cord and, starting with the tuning gang fully open, proceed as follows:—

Knot one end of the cord and anchor in the slot provided in the drive drum at the end nearest the gang. Wind the cord one turn in a clockwise direction round the drum and continue as shown in the accompanying diagram. Before winding the final turns round the drum, ensure that the tensioning pulley is exerting tension on the cord. When the winding is completed, the end of the cord must be secured round the moulded peg in the top of the drum and tucked into the groove provided. A little cellulose adhesive should be applied to the two turns round the peg.

Fit the cursor so that, with the gang fully closed, the cursor is aligned with the markers at the right-hand end of the scale. The tip of the cursor should ride on the outside of the guide loop.

F.M. TUNING**Cursor Drive**

Allowing 4ft. 3in. of nylon braided cord, tie one end to the self-tapping screw in the FM drive drum. Arrange the cord as shown in Figure 2, finishing with one complete turn round the drum.

Attach the tension spring to the end of the cord and anchor to the peg moulded in the drum so that the cord is under sufficient tension to ensure that the drive is free from any backlash. Fit the cursor so that the tip rides within the guide loop and, with the tuning spindle turned fully anti-clockwise, adjust the cursor position to align it with the scale marker at the left-hand end of the scale.

Tuner Drive

The arrangement of the tuner unit drive cord is clearly shown in Figure 2, but the following points should be noted:—

If a replacement cord is required, fit service replacement Z17223 which comprises a length of cord with tuning slugs already fitted. Difficulty will otherwise be found in fitting the slugs to a length of cord with sufficient accuracy to ensure satisfactory tracking.

Note that the tuning cores must be inserted with the closed and open ends of the cores in their correct positions as indicated in the diagram.

Check that the cursor is correctly positioned on the cursor drive cord and untie the knot in cord "A", preparatory to threading it

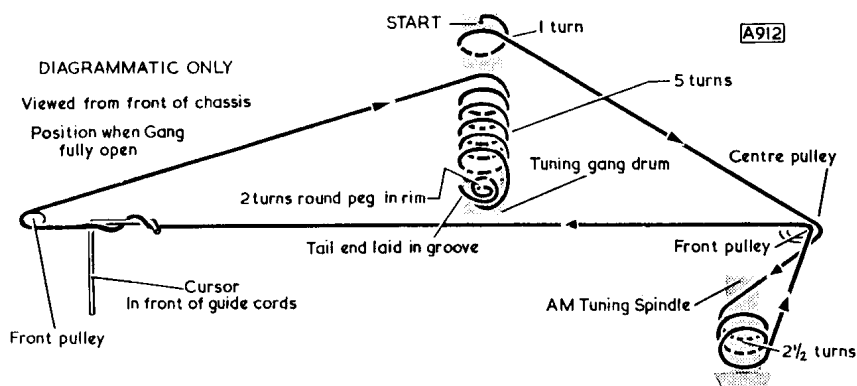

Fig. 1. The AM tuning drive cord.

SERVICE MANUAL for 384 U

FM TUNING

DIAGRAMMATIC ONLY
Viewed from front of chassis

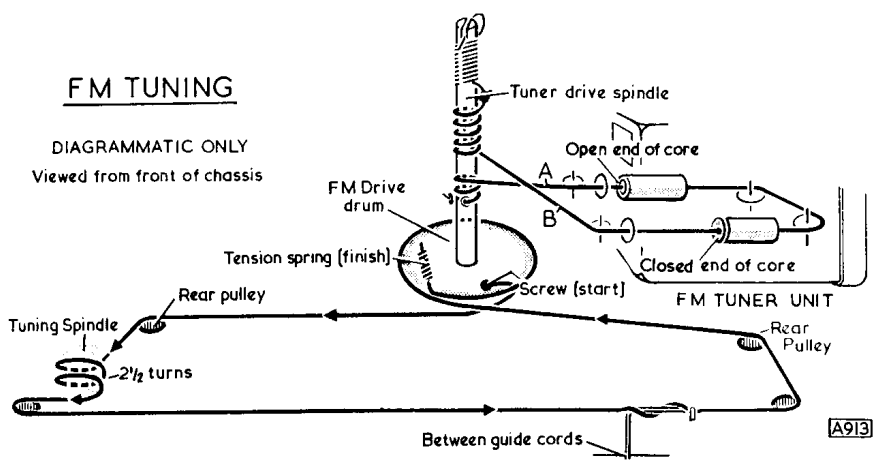

Fig. 2. The FM tuning drive cords.

through the hole in the FM drive spindle. The cord should then be re-knotted 1 in. beyond the spindle when cord "B" is pulled out to

its limit. Pull the knot up against spindle and, with the drum locking screw slackened off to allow the spindle to be rotated separately,

turn the spindle clockwise to take up any slack.

Attach the tension spring to cord "B" at approximately 4 in. from the tuner unit pulley. Tighten up the drive drum locking screws and rotate the tuning control one turn clockwise. Cord "B" may then be wound round the tuner drive spindle in an anti-clockwise direction and the tension spring anchored in the slot in the spindle as shown in the diagram. The cord must be under sufficient tension to ensure freedom from backlash.

The unit should then be re-aligned as described in "RF Alignment (FM)". After alignment, check that at extremes of cursor sweep, at least one turn of cord remains around the spindle.

Fig. 3. Locations of trimming adjustments, valves, etc. As the chassis is directly connected to one side of the mains, isolating capacitors of adequate working voltage should be used when connecting a signal generator into circuit.

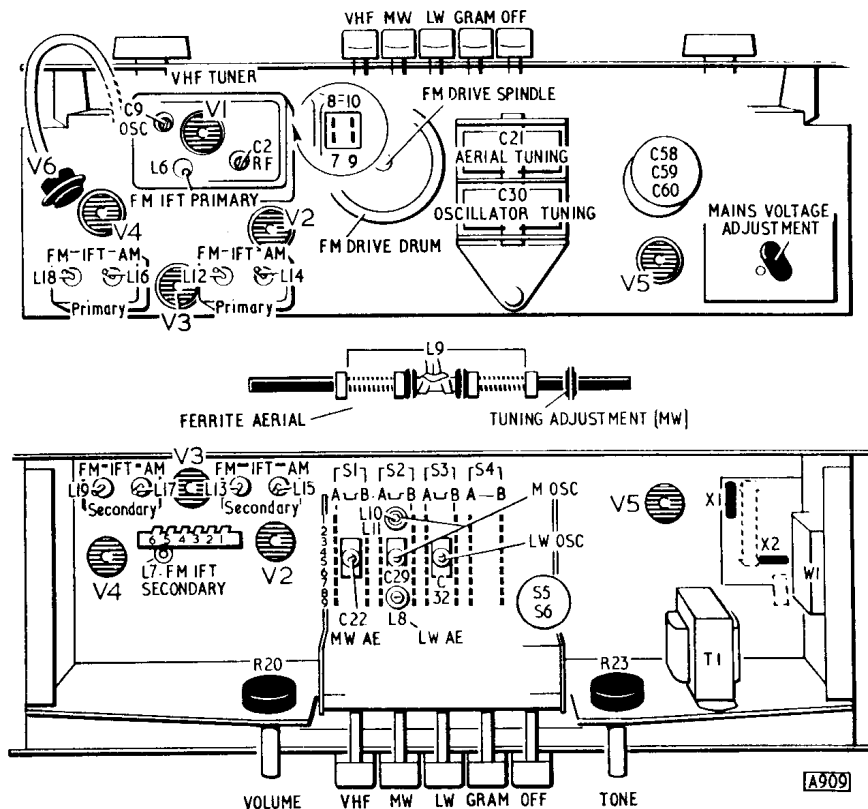

UCC85

UCH81

VOLTAGE READINGS TAKEN WITH MODEL B AVOMETER

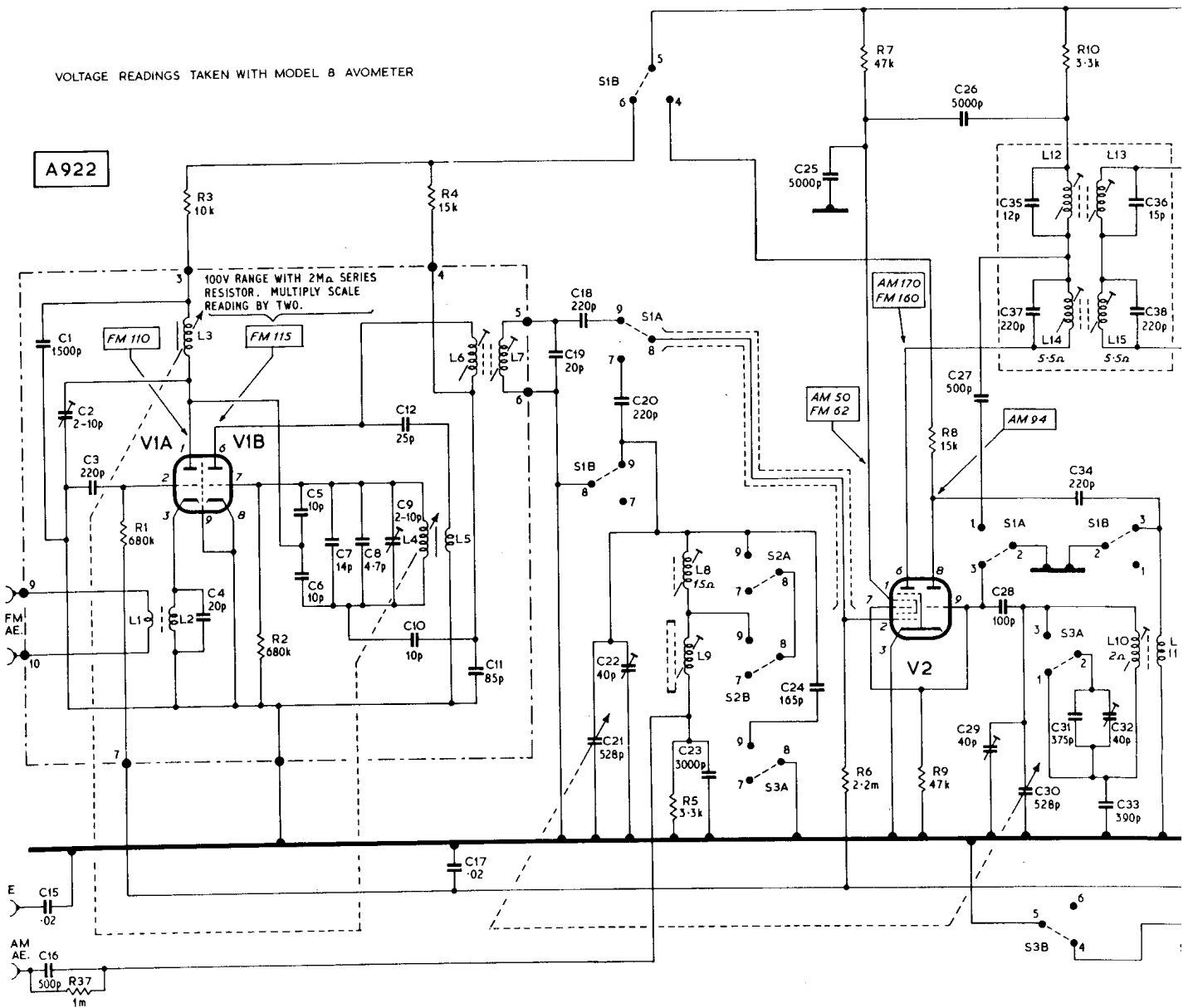
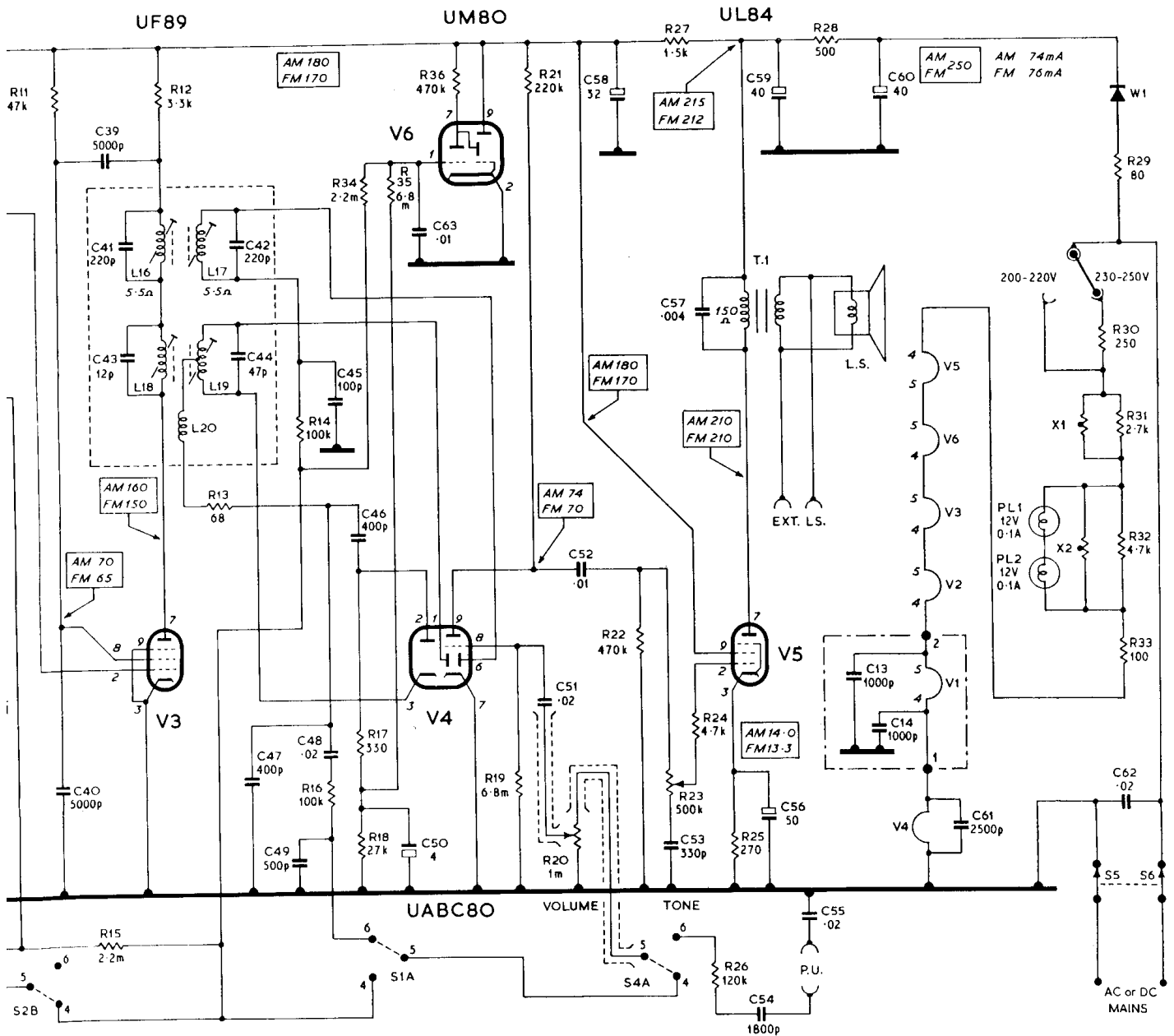
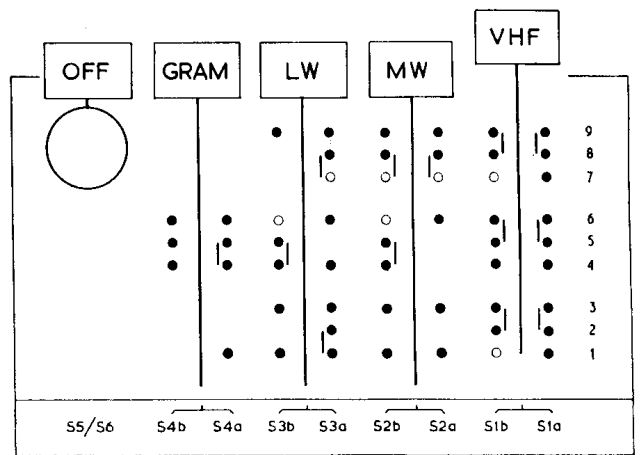

Fig. 4. Circuit diagram of model 384U, schedule B production. In schedule A production, R37 (AM aerial discharge resistor) was not fitted. The wavechange switching is shown with the VHF/FM key depressed. The single pole changeover switches shown in the diagram represent sections of the contact wafers associated with the press key switch unit. The actual arrangement of contacts on the switchbank is also shown and the groups of contacts are lettered and numbered so that they may be identified in the main diagram.



VOLTAGES—Measurements were taken with a model 8 Avometer with a mains input of 240 Volts AC (50 cycles) and the mains voltage adjustment set to 230-250 V. Readings were taken with the receiver switched to MW as well as VHF/FM.

INDUCTANCES—DC resistances, if 1 ohm or greater, are given in the diagram.



PIANO KEY SWITCH CONTACTS SHOWN IN VHF-FM POSITION. SWITCH VIEWED FROM UNDERSIDE OF CHASSIS.

ALIGNMENT DATA

A.M. CIRCUITS

I.F. Alignment

Switch the receiver to MW, turn gang to minimum capacitance position and volume control to maximum. Inject a 470 Kc/s modulated signal through a 0.1uF capacitor at the grid of **V3** (pin 2) and adjust **L17** and **L16** for maximum output.

Inject the signal at **V2** control grid (pin 2 via 0.1uF) and adjust **L15** and **L14** for maximum output. Do not make any further adjustment to **L17/L16**. Throughout alignment, adjust input signal level to maintain output at approximately 50mW.

R.F. Alignment

MW must be aligned first. Signals to be injected via a loop, loosely coupled to the ferrite rod aerial. Input level to be adjusted to maintain output at approximately 50mW.

1. With the gang at maximum capacitance, set cursor to the marker at the extreme right-hand end of the scale.
2. Switch to MW, inject 1,400 Kc/s signal and set cursor to the alignment marker near the 200 Metre calibration point. Adjust **C29** and **C22** for maximum output.
3. Set the cursor to the marker at approximately 500 Metres, inject 580 Kc/s signal and adjust **L10** and the adjusting ring on the ferrite-rod aerial for maximum output.
4. Repeat 2 and 3 until no further improvement results.
5. Switch to LW, inject 223 Kc/s signal, set cursor to the alignment marker near 1300 Metres and adjust **C32** and **L8** until no further improvement results.

F.M. CIRCUITS

The various trimming adjustments associated with the VHF/FM band must not be disturbed unless suitable equipment is available to re-align the tuned circuits. If a component is replaced in the VHF tuner unit, care must be taken to restore the wiring to its original position and ensure that the lead lengths of the replacement part are the same as in that originally fitted.

I.F. Alignment

Switch the receiver to VHF and allow to warm up for at least ten minutes. Set the volume control to maximum.

Adjustment	Signal Frequency	Point of Injection
L19, L18	10.7 Mc/s	V3 control grid (Pin 2 via .01uF)

With signal generator output of 20mV, adjust **L19**, followed by **L18**, for maximum audio output. This should be approximately 100mW.

Adjustment	Signal Frequency	Point of Injection
L13, L12	10.7 Mc/s	V2 control grid (Pin 2 via .01uF)

Adjust **L13, L12** for maximum audio output reducing input level as required so that the audio output does not exceed 100mW.

Adjustment	Signal Frequency	Point of Injection
L7, L6	10.7 Mc/s	Junction R3 and L3 (Tag 3 on VHF tuner via 500pF)

Using a non-metallic trimming tool, adjust **L7** and **L6** for maximum audio output, reducing input level as necessary.

R.F. Alignment

1. Rotate tuning control to bring cursor to the left-hand end of scale and check that the cursor coincides with the marker provided.
2. Adjust tuning control to set cursor to 91 Mc/s on scale.
3. Slacken off the locking screws of the FM drive drum and, without altering the position of the cursor, rotate the drum spindle in an anti-clockwise direction until the internal stop in the tuner prevents any further rotation. The slotted end to the spindle facilitates this adjustment.
4. Tighten up drum to spindle.
5. Rotate tuning control to bring cursor to 99 Mc/s.
6. Inject 91 Mc/s signal, frequency modulated, at the aerial sockets and adjust the oscillator trimmer **C9** for maximum output. A non-metallic trimming tool must be used.
7. Slacken off drive drum locking screws and, whilst holding the drum spindle to keep the tuner on 91 Mc/s, rotate the tuning control to bring the cursor to 91 Mc/s on tuning scale.
8. Adjust **C2** for maximum output (91 Mc/s signal).
9. Check calibration over the band and if necessary repeat 1 to 6.

SERVICE MANUAL for 384 U

CAPACITORS

Electrolytics excepted, tolerance $\pm 20\%$ unless otherwise stated. Where no working voltage is given, this should be taken as 350 Volts D.C.

Ref.	Value	Rating	Function	Part No.
C 1	1500pF	750V	V1A H.T. decoupling	
C 2	2-10pF	Pre-set	L3 tuning	Z13903
C 3	220pF	750V	V1A grid coupling	
C 4	20pF	5%	L2 tuning	
C 5	10pF	$\pm 0.5pF$ P100	Oscillator/mixer signal injection	C100H75/F13
C 6	10pF	$\pm 0.5pF$ P100		
C 7	14pF	10% P100	Part L4 tuning and temp. compensating	C140S75/F13 C47XH75/F14
C 8	4.7pF	$\pm 0.5pF$ N750		
C 9	2-10pF	Pre-set	Oscillator trimmer (F.M.)	Z13903
C10	10pF	$\pm 0.5pF$ P100	Oscillator balancing	C100H75/F13
C11	85pF	2.5%	Mixer I.F. feedback	Y850R35/SU4
C12	25pF	5%	V1B anode coupling and L6 tuning	
C13	1000pF	$-20\% + 80\%$	V1 heater R.F. bypass	
C14	1000pF	$-20\% + 80\%$		
C15	0.02uF	350V A.C.	Earth isolating	
C16	500pF	500V	A.M. aerial isolating	
C17	0.02uF	150V	A.G.C. decoupling	
C18	220pF	750V	V2 I.F. coupling (F.M.)	
C19	20pF	5%	L7 tuning	
C20	220pF	750V	V2 signal coupling (A.M.)	
C21	528pF†	Variable	Aerial tuning (A.M.)	Z25115
C22	4-40pF	Pre-set	M.W. aerial trimmer	Z13920
C23	3000pF	5%	A.M. aerial coupling	
C24	165pF	5%	L.W. aerial trimmer	S/N45753
C25	5000pF		V2 H.T. decoupling and neutralizing	
C26	5000pF		I.F. bypass	
C27	500pF	500V	V2 osc. grid coupling	
C28	100pF	750V	M.W. oscillator trimmer	Z13920
C29	4-40pF	Pre-set	Oscillator tuning (A.M.)	Z25115
C30	528pF†	Variable	L.W. oscillator trimmer	45752 Z13920
C31	375pF	Pre-set		
C32	4-40pF	Pre-set	Oscillator padder (A.M.)	Y391R35
C33	390pF	2%	V2 osc. anode coupling	
C34	220pF	750V	L12 tuning	
C35	12pF	5%	L13 tuning	
C36	15pF	5%	L14 tuning	
C37	270pF	2%	L15 tuning	
C38	220pF	2%	V3 H.T. decoupling and neutralizing	
C39	5000pF			
C40	5000pF		L16 tuning	
C41	220pF	2%	L17 tuning	
C42	220pF	2%	L18 tuning	
C43	12pF	5%	L19 tuning	
C44	47pF	5%	I.F. bypass (A.M.)	
C45	100pF	750V	I.F. filter (F.M.)	
C46	400pF	10%	Audio coupling (F.M.)	Z13210
C47	400pF	10%		
C48	0.02uF	150V	F.M. de-emphasis	
C49	500pF	500V	Ratio det. stabiliser	
C50	4uF	Electro. 100V	V4 grid coupling	
C51	0.02uF	150V	V5 C.G. coupling	
C52	0.01uF	150V	Part tone control	
C53	330pF		Pick-up isolating	Z13202
C54	1800pF	350V A.C.		
C55	0.02uF	750V	V5 cathode bypass	
C56	50uF	Electro. 25V	Tone correction	
C57	0.004uF	350V A.C.	H.T. smoothing and reservoir	Z13200
C58	32uF	Electro. 275V	V4 heater bypass	
C59	40uF	Electro. 275V		
C60	40uF	Electro. 275V	Mains R.F. bypass	
C61	2500pF	$-20\% + 80\%$	V6 grid decoupling	
C62	0.02uF	350V A.C.		
C63	0.01	150V		

† Swing value.

MISCELLANEOUS

Ref.	Function and Description	Part No.
L.S.	P.M. 3Ω speech coil, 6½" diameter	Y16002/4
PL1	Pilot lamps, 12V 0.1A	33774
PL2		
S1-S6	Piano-key switch assembly	X25149/1
W1	H.T. rectifier	Z25420
X1	Thermistors, Varite V1010	Z4558/7
X2		

RESISTORS

All carbon types unless otherwise stated. Where no tolerance or power rating is given for fixed resistors, these should be taken as $\pm 20\%$ and $\frac{1}{4}$ Watt respectively.

Ref.	Value	Rating	Function	Part No.
R 1	680KΩ		V1A grid leak	
R 2	680KΩ		V1B grid leak	
R 3	10KΩ	10%	V1A anode feed	
R 4	15KΩ	10%	V1B anode feed	
R 5	3.3KΩ		A.M. aerial shunt	
R 6	2.2MΩ		V2 hep. grid leak	
R 7	47KΩ	10%	V2 S.G. H.T. feed	
R 8	15KΩ	10%	V2 osc. anode load	
R 9	47KΩ	10%	V2 osc. grid leak	
R10	3.3KΩ		V2 hep. anode feed	
R11	47KΩ	10%	V3 S.G. H.T. feed	
R12	3.3KΩ		V3 anode H.T. feed	
R13	68Ω		L20 series	
R14	100KΩ		I.F. filter (A.M.)	
R15	2.2MΩ		A.G.C. decoupling	
R16	100KΩ		F.M. de-emphasis & I.F. filter	
R17	330Ω		Ratio detector load	
R18	27KΩ	10%		
R19	6.8MΩ		V4 grid leak	
R20	1MΩ	Log. Pot.	Volume control	Z13069/1
R21	220KΩ		V4 triode anode load	
R22	470KΩ		V5 grid leak	
R23	500KΩ	Log. Pot.	Tone control	Z13069/5
R24	4.7KΩ		V5 grid stopper	
R25	270Ω	10%	V5 cathode bias	
R26	120KΩ	10%	Pick-up series	
R27	1.5KΩ	10%	H.T. smoothing	
R28	500Ω	5%		
R29	80Ω	5%	W1 current limiter	
R30	250Ω	10%	Mains dropper	
R31	2.7KΩ	10%	X1 shunt	
R32	4.7KΩ	10%	X2 shunt	
R33	100Ω	10%	Mains dropper	
R34	2.2MΩ		Tuning indicator feed (A.M.)	
R35	6.8MΩ		Tuning indicator feed (F.M.)	
R36	470KΩ		V6 anode load	
R37	1MΩ		A.M. aerial discharge	

INDUCTORS AND TRANSFORMERS

Ref.	Function and Description	Part No.
L 1	V.H.F. aerial input transformer	Z10475
L 2		
L 3		
L 4	V.H.F. amplifier tuning	
L 6	V.H.F. oscillator feedback	
L 7	1st F.M. I.F. transformer	Y10474
L 8		
L 9	L.W. loading coil	Y25154
L10	Ferrite rod aerial	Y25424
L11	M.W. & L.W. oscillator tuning	Y25153
L12	M.W. & L.W. oscillator feedback	
L13	2nd F.M. I.F. transformer	X25651
L14		
L15	1st A.M. I.F. transformer	
L16		
L17	2nd A.M. I.F. transformer	X25144
L18		
L19	Ratio detector transformer	
L20		
T1	Audio output transformer	Z10395



FERGUSON RADIO CORPORATION LTD.
Great Cambridge Road, Enfield, Middlesex

SERVICE DEPOTS

LONDON: 145 Kentish Town Road, N.W.1 • Gulliver 6633
BIRMINGHAM: 24 Sheepcote Street, 15 • Midland 5291
MANCHESTER: 9 Stevenson Square • Central 3185
GLASGOW: 9-15 Waverley St., Shawlands, S.1 • Langside 1242

The name FERGUSON is the registered trade mark of
THORN ELECTRICAL INDUSTRIES LTD.