

H.M.V.**Model 1360**

General Description : Five-valve (including rectifier), three-waveband transportable receiver with internal frame and plate aerials and provision for external aerial.

Power Supply : A.C./D.C. mains, 190–255 volts (A.C. 40–100 c/s.). On early models, three voltage-adjustment tapplings provide coverage of the above range. On later models, a barretter (V6) is employed and no voltage adjustment is required.

Wavebands : S.W. 16.3–51.7 m.; M.W. 187–575 m.; L.W. 900–2000 m.

Valves : (V1) X142; (V2) W142; (V3) DH142; (V4) N142; (V5) U142; (V6) Barretter type 101. Typical valve voltages are shown on the circuit diagram.

Modifications : On early models a mains dropping resistor was used in place of the barretter; see diagram. In later production models R7 is 33k.

Alignment Procedure : *I.F.* : With gang fully open, inject a 470-kc/s. signal via a 0.1- μ F. capacitor to signal grid of V1 (pin 6) and earth socket. Adjust cores L14, L13, L12 and L11 in that order for maximum output. Repeat adjustments until no further improvement can be obtained.

R.F. : Inject test signals into aerial and earth sockets via standard dummy aerials.

| Operation | Test Oscillator | | Tuning Gang | Adjust for Maximum Output |
|-----------|-----------------|--------|---------------------|---------------------------|
| | kc/s. | metres | | |
| (1) M.W. | 522 | 575 | Almost maximum | L7 |
| (2) | 1602 | 187 | Almost maximum | TC5 |
| (3) | 588 | 510 | Tune in | L3 |
| (4) | 1427 | 210 | Tune in | TC3 |
| (5) | | | Repeat (1) to (4) | |
| (6) L.W. | 150 | 2000 | Almost maximum | L9 |
| (7) | 333 | 900 | Almost minimum | TC6 |
| (8) | 162 | 1852 | Tune in | L4 |
| (9) | 300 | 1000 | Tune in | TC1 |
| (10) | | | Repeat (6) to (9) | |
| (11) S.W. | 5.8 Mc/s. | 51.7 | Almost maximum | L5 |
| (12) | 18.4 Mc/s. | 16.3 | Almost minimum | TC4* |
| (13) | 6 Mc/s. | 50 | Tune in | L2 |
| (14) | 17.8 Mc/s. | 16.85 | Tune in | TC2 |
| (15) | | | Repeat (11) to (14) | |

* Take care to avoid image channel, *i.e.*, when TC4 is adjusted from the underside of the chassis the first peak from the fully "screwed in" position is the correct one.

Notes : Scale lamps, two 5-volt, 0.15 amp. Two 500-mA. cartridge-type fuses.

Before replacing the chassis in the cabinet, check the calibration at about the centre of the wave scale on each waveband. Adjust pointer to provide a compromise if necessary.

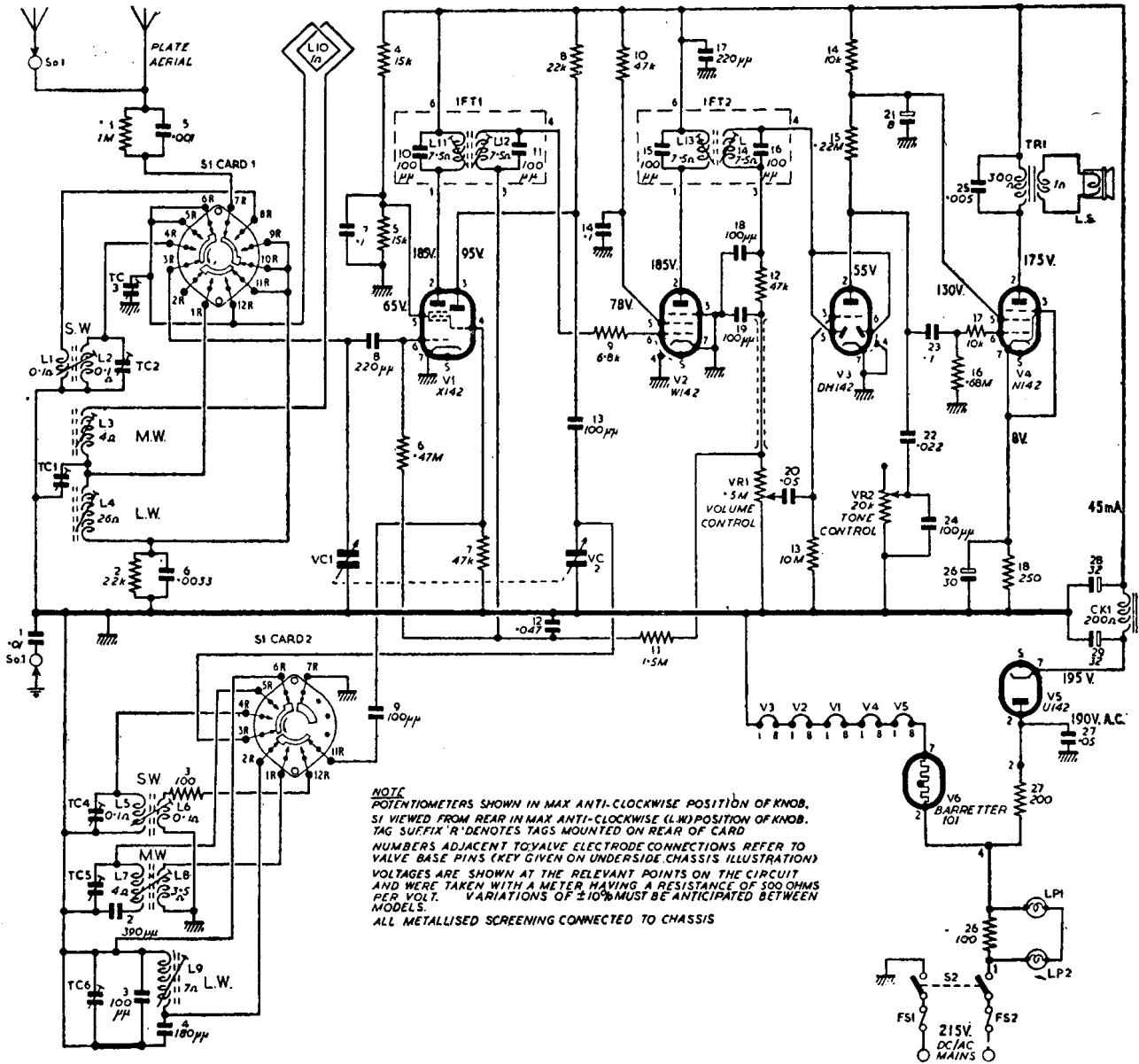

CIRCUIT DIAGRAM—H.M.V. MODEL 1360

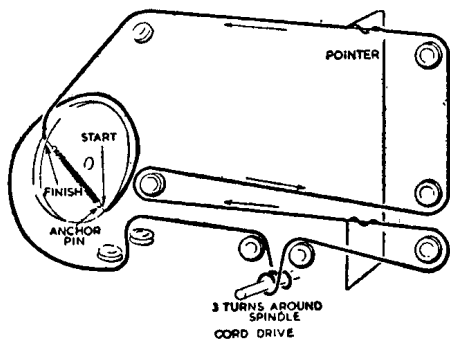

CORD-DRIVE SYSTEM

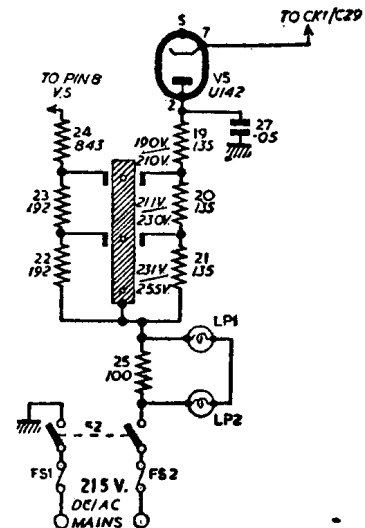

MODIFIED MAINS INPUT CIRCUIT USED
 ON EARLY MODELS

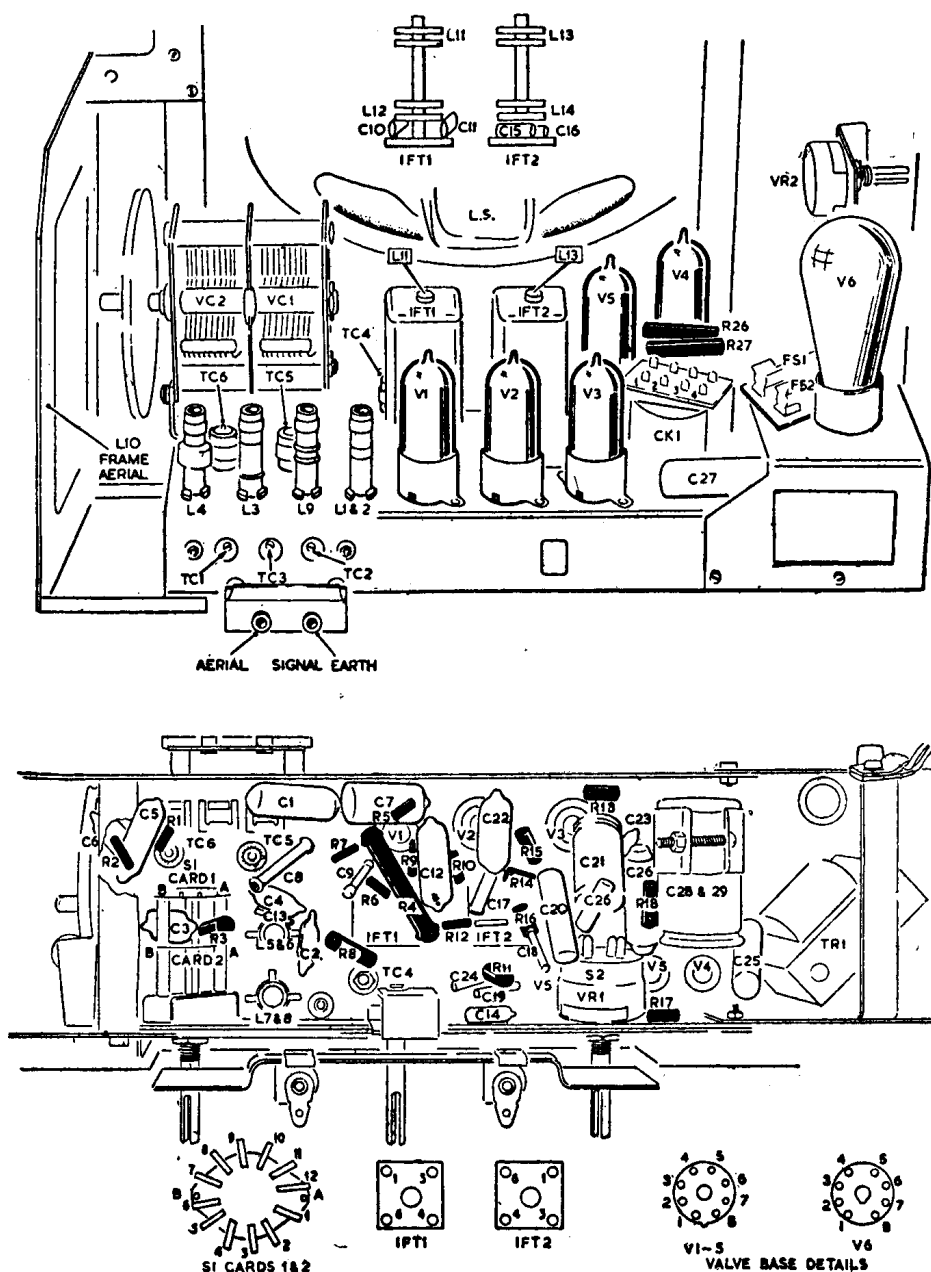

CHASSIS LAY-OUT DIAGRAMS—H.M.V. MODEL 1360

Cord Drive : Use specified nylon cord Type 6370 × 0012. Approximately 67 in. required. (1) Form loop at one end of cord and pass loop through the hole (nearest the anchor pin) in periphery of drum. (2) Fix loop on to anchor pin. (3) Wind cord on to pulleys as shown and pass end of cord through other hole in drum periphery. (4) Attach this end of cord to one end of spring and fix free end of spring on to anchor pin. (5) Seal knots with shellac to prevent slipping.

Removing Chassis : Disconnect from mains supply. Complete access to the chassis can be gained by removing the card back and underside cover (four screws). The chassis, complete with baffle board and escutcheon, may be withdrawn by removing the tone-control knob and the six bolts securing the baffle board to the cabinet moulding.