

# 'TRADER' SERVICE SHEETS

## LISSEN 8118 4-VALVE TRANSPORTABLE

A FRAME aerial is fitted in the Lissen 8118 receiver, which is a transportable type for battery operation. The circuit consists of a variable-mu tetrode H.F. amplifier, a triode detector, a triode driver and a double-triode Class B output valve. Provision is made for a gramophone pick-up and an external aerial and earth.

### CIRCUIT DESCRIPTION

Tuned frame aerial input **L2, L3, C13** (with provision for external aerial coupling by **L1**) to variable-mu tetrode H.F. amplifier (**V1, Ever Ready metallised K40N**). Gain control by variable potentiometer **R2** which varies G.B. applied.

Choke-fed tuned grid coupling by **L4, C3, L7, L8, C16** to triode detector (**V2, Ever Ready metallised K30C**) operating on grid leak system with **C4** and **R4**. Reaction is applied from anode by coils **L5, L6** and controlled by variable condenser **C15**. H.F. filtering in anode circuit by choke **L9** and by-pass condenser **C6**. Provision for connection of gramophone pick-up in grid circuit.

Parallel-fed transformer coupling by **R6, C7** and **T1** to triode driver valve (**V3, Ever Ready metallised K30E**), which is coupled by **T2** to positive drive Class B output valve (**V4, Ever Ready K33B**). Fixed tone correction by condensers **C9, C10** and **C11**; two-point tone control by condenser **C12** and plug and socket device. Coupling to speaker by special input transformer **T3**.

Gain control **R2** and fixed resistance **R3** are connected in parallel and together form G.B. battery load. The rate of discharge is arranged to provide a

degree of G.B. compensation as the H.T. voltage falls.

### COMPONENTS AND VALUES

Resistances		Values (ohms)
R1	V1 cont. grid decoupling ..	100,000
R2	V1 gain control ..	5,000
R3	Part of G.B. battery load ..	2,000
R4	V2 grid leak ..	2,000,000
R5	V2 anode decoupling ..	20,000
R6	V2 anode load ..	30,000
R7	V3 grid H.F. stopper ..	100,000

Condensers		Values ( $\mu F$ )
C1	V1 cont. grid decoupling ..	0.1
C2	V1 S.G. by-pass ..	0.1
C3	H.F. coupling to L7, L8 ..	0.0001
C4	V2 grid condenser ..	0.00005
C5	V2 anode decoupling ..	0.5
C6	V2 anode H.F. by-pass ..	0.0003
C7	L.F. coupling to T1 ..	0.1
C8	H.T. reservoir ..	1.0
C9	Tone correctors ..	0.002
C10		0.002
C11		0.002
C12		0.005
C13	Frame aerial tuning ..	—
C14	Frame aerial trimmer ..	—
C15	Reaction control ..	0.0005
C16	H.F. circuit tuning ..	—
C17	H.F. circuit trimmer ..	—

† Variable. ‡ Pre-set.

Other Components		Approx. Values (ohms)
L1	External aerial coupling ..	1.4
L2	Frame aerial windings ..	1.3
L3		12.4
L4	V1 anode H.F. choke ..	500.0
L5	Reaction coils ..	2.2
L6		4.6
L7	H.F. tuning coils ..	1.4
L8		19.6
L9	V2 anode H.F. choke ..	500.0

Other Components (contd.)		Approx. Values (ohms)
L10	Speaker speech coil ..	2.4
T1	Intervolve trans. { Pri ..	1,100.0
	Sec. ..	10,000.0
T2	Driver trans. { Pri ..	480.0
	Sec. total ..	390.0
T3	Speaker input trans. { Pri total ..	550.0
	Sec. ..	0.6
S1, S3	Waveband switches ..	—
S2	G.B. switch ..	—
S4	L.T. switch ..	—

### DISMANTLING THE SET

**Removing Chassis.**—To remove the chassis from the cabinet, remove the back (four coin-slot screws), and disconnect and remove the batteries. Remove the three control knobs (pull off) and disconnect the five frame aerial connections, the three leads to the speaker transformer and the "earthing" lead to the speaker frame. Remove the nuts, washers and collars from the two bolts holding the chassis to the front of the cabinet, and the threaded collars and washers from the two bolts holding the chassis to the sides of the cabinet. The chassis is now free.

**When replacing,** note that the frame lead nearest to the back of the chassis goes to the top connection on the frame and the others are connected in order, that the two black speaker leads go to the outside tags, with the red lead to the centre tag, that the control knobs are marked with their purpose so that they must be placed on the correct spindles, and that the two knurled coin-slot screws are used for that part of the back which covers the battery compartment.

**Removing Speaker.**—To remove the speaker from the cabinet, take off the nuts, lock washers and washers from the four bolts holding it to the sub-baffle. **When replacing,** see that the transformer is pointing to the bottom right-hand corner of the cabinet, do not forget to replace the tag for the earthing lead on the top bolt, and connect as above.

**Removing Frame Aerial.**—If it is necessary to remove the frame aerial, remove the cross support across the back of the cabinet (four countersunk-head wood screws) and remove the nuts and

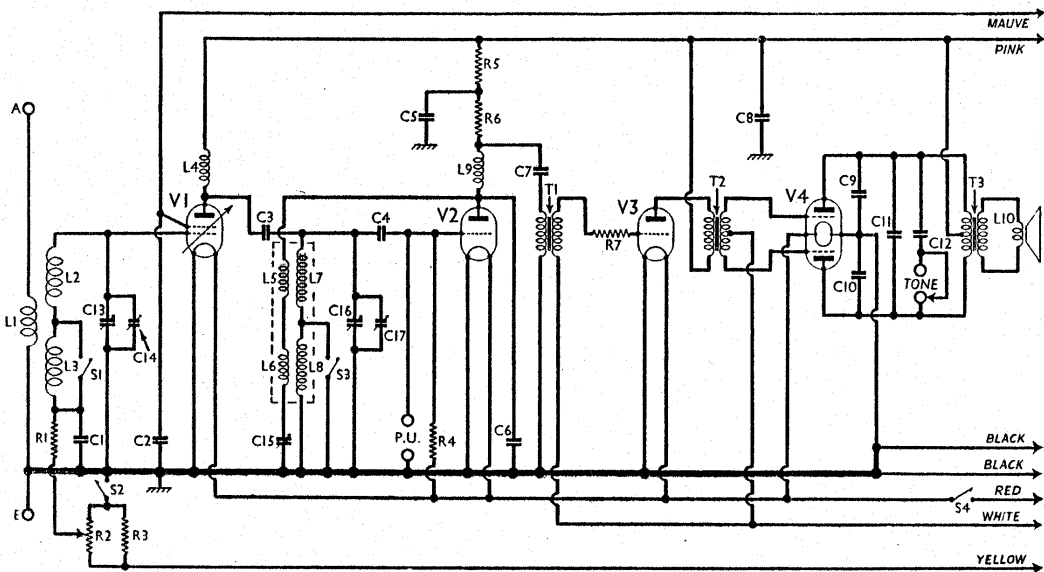

Circuit diagram of the Lissen 8118 transportable receiver. L2 and L3 are the frame windings, L1 being an external aerial coupling coil.

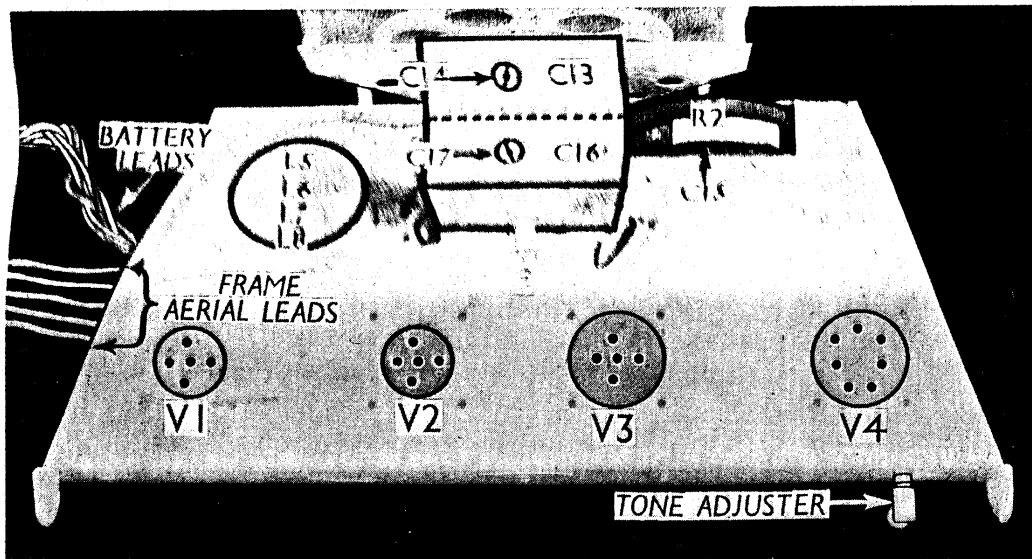

Plan view of the chassis. R2 and C15 form a combined gain and reaction control. Note the tone adjuster plug and socket device.

washers from the four bolts with ornamental heads holding the frame to the front of the cabinet. When replacing, see that the frame connections are on the left and connect as above.

**VALVE ANALYSIS**

Valve voltages and currents given in the table below were measured with the receiver operating from new batteries.

Valve	Anode Volts	Anode Current (mA)	Screen Volts	Screen Current (mA)
V1 K40N	118	0.5	55	0.2
V2 K30C	55	1.1	—	—
V3 K30E	115	2.4	—	—
V4 K33B	115†	1.7†	—	—

† Each anode.

the H.T. reading 128 V. The volume control was turned so that the slider was at the end of the winding but the plates of the reaction condenser were not fully in mesh, that is the control was turned through an angle of about 125 degrees. There was no signal input, the frame aerial connections being shorted together.

Voltages were measured on the 1,200 V scale of an Avometer, chassis acting as negative.

Under-chassis view. R5, R6 and C7 are mounted above T1. L4 is an H.F. choke.

**GENERAL NOTES**

**Switches.**—The two waveband and two battery switches are ganged in a single unit beneath the chassis. S1 and S3, the waveband switches, are both closed on the M.W. band and open on the L.W. band. S2 and S4 are both open when the set is "Off," and closed on both the M.W. and L.W. positions.

**Coils.**—The frame aerial and aerial coupling coils L1-L3, are in the cabinet of the set. The remaining tuning and reaction coils, L5-L8, are in a single screwed unit on the chassis deck, L5 and L7 being iron cored.

L4 and L9 are two flat H.F. chokes, mounted beneath the chassis.

**External Speaker.**—No provision is made for this, but a low resistance type (about 2.5 Ω) could be connected across the two secondary tags of the internal speaker transformer.

**Transformer T1.**—This is beneath the paxolin panel carrying R5, R6 and C7.

**Batteries.**—The L.T. cell is a Lissen

2 V 28 AH celluloid type, No. LN88or8. The H.T. and G.B. battery is a Lissen 120 V, No. LN3010. Note that this battery has the first 9 V tapped in 1.5 V steps from negative upwards. Consequently the plug which is inserted into the H.T. negative socket is the maximum G.B. tapping, while that in the 9 V positive socket is the H.T. negative and G.B. positive connection.

**Battery Leads and Voltages.**—Black with spade tag, L.T.—; Red with spade tag, L.T.+; Yellow, H.T.—socket; white, H.T. 6 V socket; Black, H.T. 2 V socket; Mains, H.T. 50 V socket; Pink, H.T. 120 V socket.

**Components, R2, C15.**—These form the combined gain and reaction control, in a single unit, arranged so that the vanes of C15 do not begin to mesh until the slider of R2 has passed the end of the resistance element.

**Tone Adjuster.**—This is a simple plug and 2-socket device. When the plug is in the right-hand socket ("Low" position) condenser C12 is connected across the primary of T3, in parallel with C11. With the plug in the left-hand socket ("High"), C12 is not connected.

