

# Wireless Retailer & BROADCASTER SERVICE ENGINEER Section

## MARCONIPHONE 219 FIVE-VALVE A.C. SUPERHET

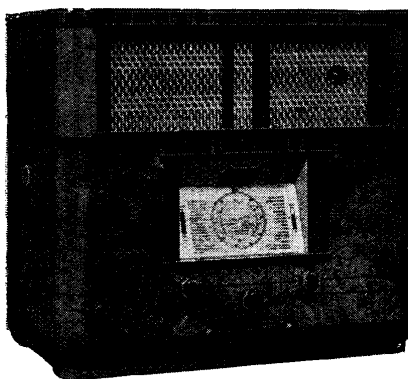

The 219 is automatically silenced between stations by a switch associated with the tuning control. The four-valve plus rectifier chassis is also used in the 239 radiogram.

**CIRCUIT.**—Aerial signals are fed by a band-pass filter to the hexode mixing valve V1. The I.F. signal, which is 125 k.c., is passed through the I.F. band-pass transformer and on to the H.F. pentode, V2, the I.F. valve. The second I.F. transformer is coupled to the separate double-diode, V3.

The L.F. signal is passed through the volume control, V.R.I., on to the L.F. amplifying valve V4. To the grid of this valve is applied the bias for operating a mechanical "Q" circuit. This valve is coupled to the output pentode V5 via a resistance capacity network.

Tone correction is applied to the grid of this valve by the use of C16 and the choke coil CK1. S4 is the tone control switch, a double-gang type, the second gang switching the pentode correction circuit consisting of C33, C36 and R35.

A.V.C. is applied to the grids of V1 and V2 in the usual manner.

**Removing Chassis.**—Remove the speaker cable and mains cord from their respective cleats. Remove the volume, tuning and wave-change knobs by taking out the sunken self-threading screws. The tone control and "Q" control knobs are fitted with hollow shanks, and are removed by pulling off.

Remove the four fixing bolts found underneath the cabinet. The chassis will then slide out of the cabinet far enough to enable close inspection and testing.

If it is necessary to remove the chassis entirely, unscrew the mains switch (S2)

leads located on the mains transformer terminal strip on top of the chassis (these are marked "switch"). Then, to remove the speaker, unscrew the two bolts holding the speaker bar.

**Special Notes.**—The main pilot lamp and the tuning indicator lamp are easily accessible. The wave-change pilot light is clamped on to the scale assembly, and can be removed by pulling up. To replace the tuning scale pilot lamp it is only necessary to turn the condenser to minimum. The lamp rating is 6.2 v., .3 amp.

The mechanical "Q" circuit switch, S3, is mounted on the front of the chassis, and is operated by a forked friction member on the main tuning condenser shaft. The "Q" circuit is put out of action by turning S5 to the left.

The output transformer is mounted to the left-hand side of the speaker in the cabinet.

### ALIGNMENT NOTES

**I.F. Circuits.**—Connect a modulated oscillator between the grid of V2 and earth and adjust the trimmer condenser TC6 (this is the top trimmer on the back of IFT2), and TC7 (bottom trimmer on IFT2) for maximum output at 125 kc.

Remove the oscillator from V2 and

### QUICK TESTS

Voltages between chassis and terminal plate on the right-hand side on back of chassis, are as follows:—

Red lead (7), smoothed H.T. . . . . 240 volts  
 Yellow-red lead (8), V5 anode . . . . . 220 volts  
 Black lead (3), chassis link . . . . . 0 volts  
 Yellow-black lead (6), neg. bias volts . . 150 volts  
 Yellow, speech coil.

When measuring neg. bias volts, the chassis is positive in respect to the yellow-black terminal.

### VALVE READINGS

No signal. Volume control maximum.

V	Type.	Electrode.	Volts.	M/a.
1	Marconi MX40 (7) met.	Anode ..	210	2.0
		Screen ..	60	2.0
		Osc. anode	90	2.5
2	Marconi VMP4 G (7) met.	Anode ..	152	3.5
		Screen ..	80	2.8
3	D 41 Marconi (5) met.	Diode ..	—	—
4	Marconi MH4 (5) met.	Anode ..	96	2.0
5	Marconi MPT4 (5) met.	Anode ..	220	30.0
		Screen ..	208	5.0
6	Marconi U12 (4)	Rectifier	—	—

### USING "SERVICE ENGINEER"

**VOLTAGE** readings given in the new SERVICE ENGINEER reviews are measured with highly efficient instruments. When voltmeters of average efficiency are employed, readings slightly lower than those given will usually be obtained.

This is due to the greater current passed by the meter. The voltage drop is most considerable when there are high resistances in circuit between the meter and H.T. +.

In referring to chassis lay-outs, the identification of a component is greatly facilitated by remembering that resistors are indicated in solid black and condensers are shown in outline. Top-of-chassis diagrams are distinguishable from underneath diagrams at a glance by the "tint."

connect to the grid of V1 and adjust TC4 (bottom trimmer on IFT1) to 127 kc., and TC3 (top trimmer on IFT1) to 123 kc.

Check up by repeating the preceding and make a final check by sweeping the oscillator between 123, 125 and 127 kc. The output should be greatest at 125 kc. If the results are not correct, then re-adjust TC6 and TC7.

The output of the oscillator should be kept below the A.V.C. level, and it is best to put the "Q" circuit out of operation.

**Medium-wave Band.**—Connect modulated oscillator to the aerial and earth of the set and adjust both the oscillator and the set to 220 m. Adjust VC3 (oscillator trimmer) for maximum output. Next adjust VC2 (B.P.2 trimmer) for maximum output, and, lastly, adjust the series aerial condenser TC1.

Tune the oscillator and set to 525 m. and adjust the trimmer on top of oscillator coil for maximum output.

Recheck the above procedure.

**Long-wave Band.**—Tune the oscillator and the set to 1,000 m. and adjust the long-wave padding condenser TC5 and the long-wave TC2 for maximum.

(For Circuit and Layout see next page.)

**Service Engineer  
Section**

**MARCONIPHONE 219 (Continued)**

CONDENSERS		
C.	Purpose.	Mfd.
1	Trap circuit shunt ..	.023
2	Trap circuit series ..	.023
3	V1 bias decoupling ..	.1
4	V1 osc. grid ..	.0001
5	V1 screen decoupling ..	.1
6		
7	V1 osc. H.T. decoupling ..	1.0
8	V2 H.T. decoupling ..	.1
9	V2 screen decoupling ..	.1
10	AVC decoupling ..	.1
11	V2 cathode bias decoupling ..	.0001
12	Diode coupling ..	.0001
13	Diode decoupling ..	.0001
14	Bias decoupling (B) ..	.25
15	L.F. feed ..	.1
16	Part of tone control ..	.0023
18	V4 anode decoupling ..	1.0
19	Coupling to V5 ..	.1
20	Coupling to V4 ..	.1
21	"Q" circuit decoupling ..	.1
22	V5 screen decoupling ..	1.0
23	H.T. smoothing ..	4.0
24	V5 bias decoupling ..	.1

*Continued in next Column.*

RESISTANCES		
R.	Purpose.	Ohms.
1	V1 bias cathode ..	500
2	V1 DSC grid leak ..	50,000
3	AVC decoupling ..	100,000
4	V1 and V2 screen decoupling ..	15,000
5	V1 osc. anode decoupling ..	50,000
6	V1 osc. anode ptr. ..	23,000

*Continued in next column*

CONDENSERS (Continued).		
C.	Purpose.	Mfd.
25	H.T. smoothing ..	8.0
26	Mains aerial ..	.00035
27	V2 AVC decoupling ..	.1
28	V1 anode by-pass ..	.0001
29	H.F. by-pass ..	.00023
30	Bias decoupling ..	.1
32	L.W. padding ..	.0023
33	Pentode correction ..	.001
34	Trap circuit ..	.01
35	H.T. decoupling for V1 ..	.01
36	Pentode correction ..	.1
TC1	Series aerial ..	—

RESISTANCES (Continued).		
R.	Purpose.	Ohms.
7	V1 osc. anode ptr. ..	35,000
8	V2 cathode bias ..	500
9	Part of AVC ptr. ..	.23 meg.
10	AVC decoupling ..	.5 meg.
12	Diode decoupling ..	.23 meg.
13	Diode load ..	50,000
14	Part of V4 anode ptr. ..	35,000
15	Part of V4 anode ptr. ..	35,000
16	Part of "Q" circuit ptr. ..	750
17	Part of "Q" circuit ptr. ..	1,500
18	"Q" circuit decoupling ..	.5 meg.
19	V4 grid stabiliser ..	.15 meg.
20	"Q" circuit decoupling ..	.23 meg.
21	V5 bias ..	.1 meg.
22	V5 grid stabiliser ..	5,000
23	V5 screen decoupling ..	5,000
24	Part of "Q" circuit ..	1.5 meg.
25	V5 bias decoupling ..	.35 meg.
26	V5 bias ptr. ..	.5 meg.
28	V5 bias ptr. ..	50,000
29	V1 osc. anode decoupling ..	5,000
30	Part of AVC ptr. ..	.5 meg.
31	AVC decoupling ..	.75 meg.
33	Part of "Q" circuit ..	1.5 meg.
35	Pentode correction ..	23,000
VR1	Volume control ..	.5 meg.
VR2	Hum control ..	48

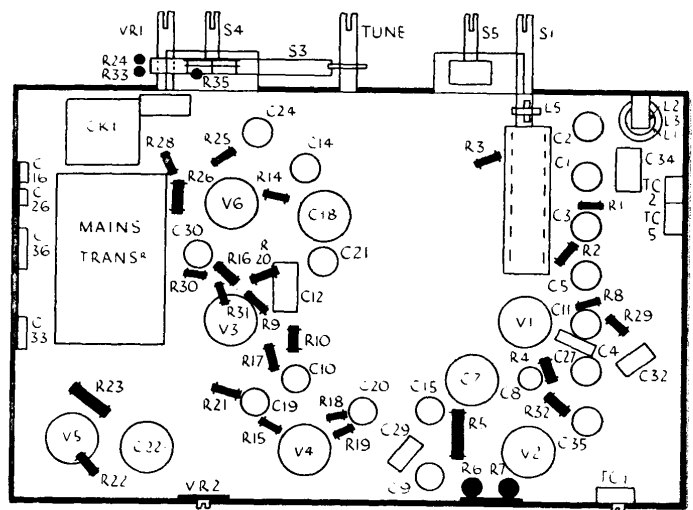
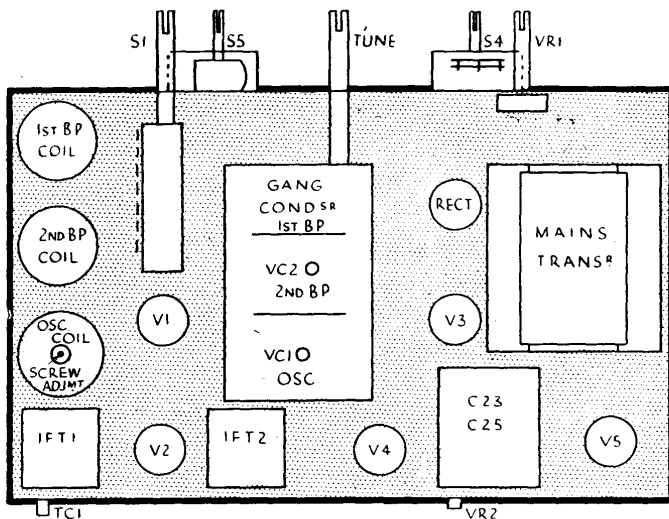

These diagrams show (left) how the components are arranged on the top of the 219 chassis, and (right) the "below deck" arrangement. Reference is made to the mechanical silencing switch under "Special Notes" on the previous page.

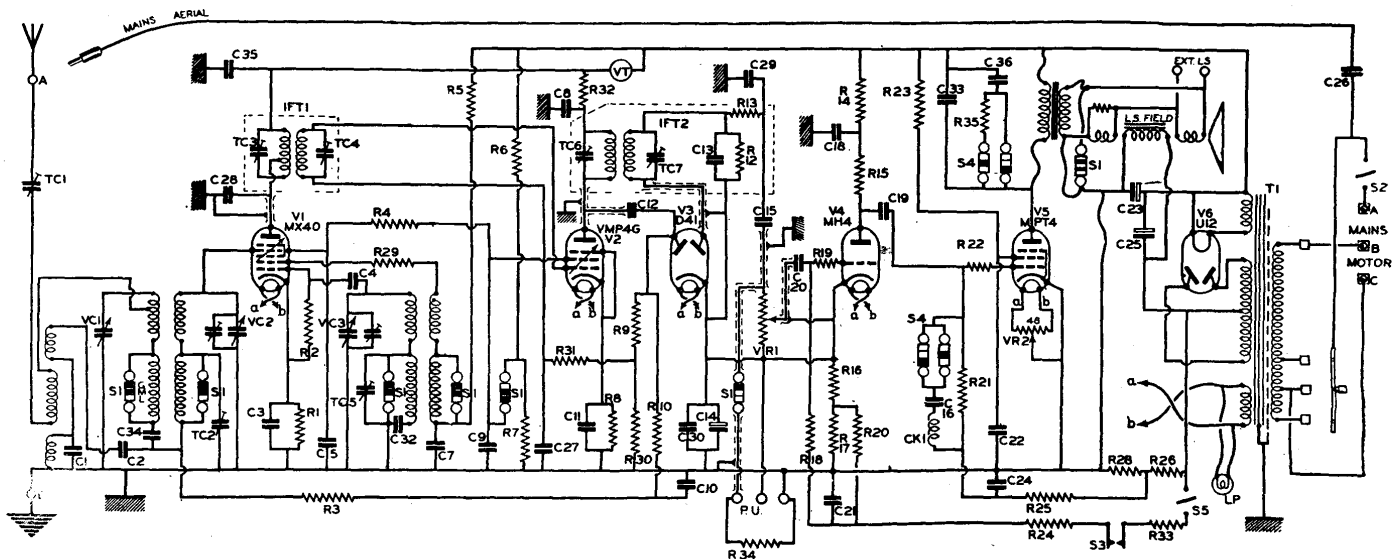

A comparatively straightforward four-valve plus rectifier superhet arrangement is employed in the 219. The "Q" switch applies a silencing bias to V4.