

Wireless Retailer & BROADCASTER SERVICE ENGINEER Section

MARCONIPHONE 345 ALL-WAVE SET

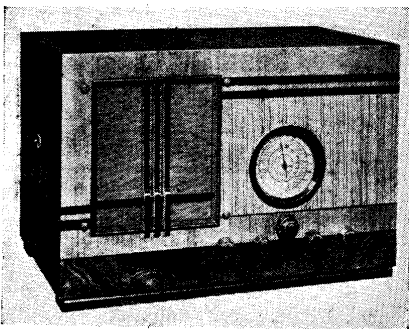

The model 345 receiver by Marconiphone is a 6-valve A.C. mains superhet with provision for four wavebands.

CIRCUIT.—An H.F. valve (V1) is preceded by a tuned secondary aerial transformer, in which separate switching is used for the four wavebands. An additional resistance R67 in the cathode lead acts as a whistle suppressor. This is short-circuited on the short wavebands.

Bias is by cathode resistance and A.V.C., and coupling to the next valve is by a tuned secondary H.F. transformer.

The first detector oscillator (V2) is used in the orthodox manner with tuning in the grid circuit, and is coupled to the I.F. valve (V3) by a band-pass I.F. transformer.

The second detector and L.F. amplifier (V4) is resistance capacity coupled to the output pentode (V5).

Special Features.—The switch at the back of the chassis is for "gram."

The tone controls are simple. The top note control places condensers of different values across the primary of the output transformer. The bass adjuster connects condensers of different values into the coupling between V4 and V5.

The A.V.C. is operative on V1, V2 and V3 on the three higher wavelengths, but on the shortest wavelength the grid coils are connected direct to chassis, and therefore A.V.C. is not applied.

The pilot lamps are 6 v. .3 amp. type, and are clipped on to the brackets.

Removing the Chassis.—Undo the knobs (grub screws), free the speaker and switch leads from the cleats at the side of the cabinet and the mains cable from that in the bottom. Remove the holding screws from underneath.

General Notes.—The trimming condensers are reached from underneath the chassis and are shown as T's in the lay-out diagram. The M.W. and L.W. tracking condensers T21 and C24 with T25 are situated at the back of the chassis, while

the two short-wave trimmers are under their respective coil.

The tuning arrangement in this set is novel, and as it requires careful handling the following removal instructions will be useful:—

- (1) Turn moving vanes fully out.
- (2) Remove pilot lamps by pulling the clips sideways.
- (3) Gently remove the pointers by easing the bosses (similar to clock hands). The groove in the centre spindle does not unscrew. It is intended to help the grip of the black pointer.
- (4) Remove the scale by releasing the bent clips round the periphery.
- (5) Unscrew the nut holding the two gear wheels and spring cage. Remove the nut while holding the outer gear wheel and the spring cage together to prevent the spring being released.

(6) Remove the centre pinion (note that the centre gear wheel is riveted to the spindle, and no attempt should be made to remove it).

(7) Slacken both the grub screws of the friction disc and condenser spindle.

(8) Remove the top bolt fixing the scale housing to the end plates of the condenser. (revealed when the top gear wheels are removed). The lower fixing bolt can be reached through the hole just below the centre gear wheel.

(9) The tuning drive assembly may then be removed complete.

In refitting the reverse order of proce-

dures should be used, with the following precaution:—

When replacing the outer gear wheel and spring cage (operation 5 in removal), the correct tension for the spring will be obtained by twisting the spring cage one turn in an anti-clockwise direction before tightening the locking-nut. If there is any tendency to backlash in the drive the spring should be tightened still further.

ALIGNMENT NOTES

In carrying out the ganging the bass control should be at minimum, the brilliance control at maximum, and the volume control at maximum.

I.F. Circuits.—Turn set to M.W. and tune to maximum capacity of the tuning condenser. Inject output from modulated oscillator between the fixed vanes of VC2 and chassis.

Proceed as follows: (1) Tune oscillator to 460 kc.; (2) adjust trimmers, T32, T33, T35, T36, in that order, for maximum on the output meter; (3) check these adjustments.

H.F. Circuits.—Connect mod. oscillator to A. and E. terminals and make sure that for maximum capacity the pointer is 0 on the big scale and 50 on the small one.

Long Waveband.—(1) Set mod. oscillator and receiver to 750 m.; (2) trim T22 to maximum; (3) set mod. oscillator to 775 m. and adjust T9 and T1 for maximum; (4) change oscillator to 1,700 m. and tune in the signal on the receiver; (5) adjust T21 for maximum irrespective of the calibration, at the same time slightly rocking the tuning condenser; (6) check these adjustments.

Medium Waveband.—(1) Adjust receiver and mod. oscillator to 185 m.; (2) tune T23 for maximum; (3) adjust oscillator to 205 m. and tune in on receiver; (4) adjust T10 and T2 for maximum; (5) adjust oscillator to 500 m. and tune in on receiver; (6) adjust T25 for maximum irrespective of calibration; (7) check these adjustments.

S1 Waveband.—Adjust oscillator and receiver to 46 m.; (2) trim T26 for maximum; (3) adjust oscillator to 50 m. and tune in on receiver; (4) adjust T11 and T3.

S2 Waveband.—(1) Adjust oscillator and receiver to 16.7 m.; (2) trim T28 (there are two points at which the signal will be received, and the position of minimum capacity is the correct one); (3) adjust oscillator to 17.5 m. and tune in the signal on the receiver; (4) trim T12 and T4 for maximum (the adjustment of T12 is particularly critical); (5) check these adjustments.

For Circuit and Chassis Layouts, see next page.

QUICK TESTS

Voltages between the following numbered terminals on the speaker transformer and chassis should be:—

- (4) Red with black tracer (H.T. smoothed) 265 volts.
- (5) Red (H.T. unsmoothed) 365 volts.
- (3) Red with yellow tracer (output valve anode) 232 volts.

The speaker field is between (5) and (4) and the speaker transformer primary between (4) and (3).

VALVE READINGS

On Medium Waves with No Signal.

V.	Type.	Electrode.	Volts.	M.A.
1	VMP4G met (7)	anode	250	.5
		aux. grid	65	2
2	X41 met (7)	anode	250	2.5
		aux. grid	65	2.5
		osc. anode	100	5
3	VMP4G met (7)	anode	250	4.5
		aux. grid	65	2
4	MHD4 met (7)	anode	105	2
		aux. grid	220	41
5	N41 (7)	anode	220	41
		aux. grid	265	10
	U 12 Rectifier.	filament	365	—

Service Engineer Section

MARCONIPHONE 345 (Continued)

Left, the plan chassis diagram. Right, the layout of the underside.

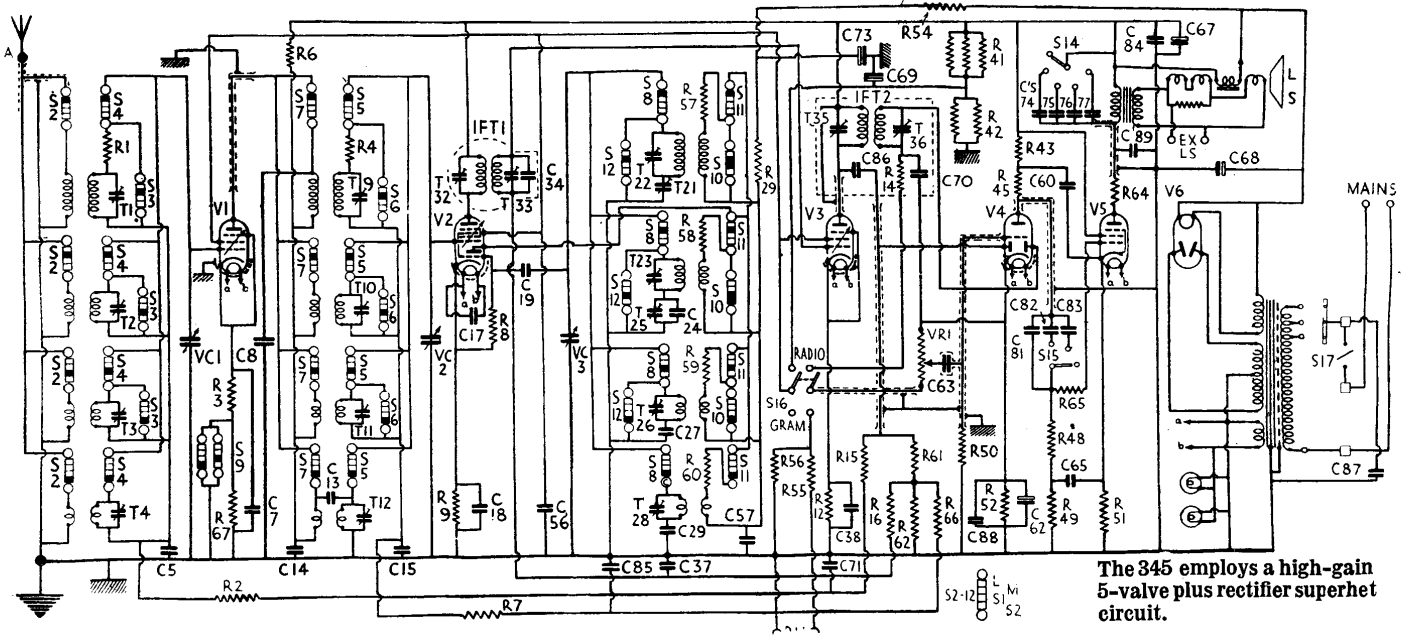
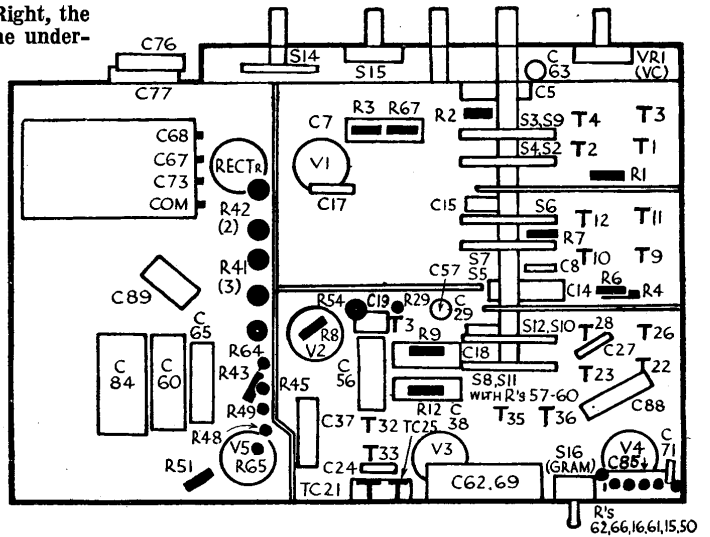
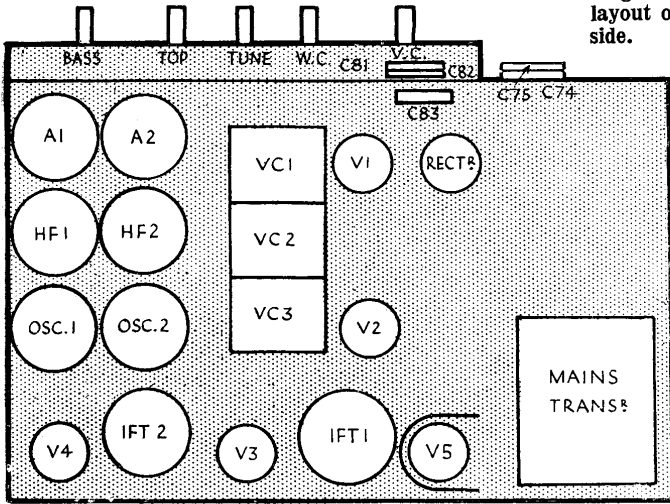

The 345 employs a high-gain 5-valve plus rectifier superhet circuit.

RESISTANCES		
R.	Purpose.	Ohms.
1	V1 grid stabilising	100
2	Decoupling V1 grid	100,000
3	V1 bias	150
4	Stabilising V2 grid	100
6	Decoupling V1 anode	1,000
7	Decoupling V2 grid	100,000
8	V2 osc. grid leak	50,000
9	V2 cathode bias	150
12	V3 cathode bias	150
14	H.F. stopper	50,000
15	Decoupling A.V.C.	1.5 meg.
16	Decoupling A.V.C.	1 meg.
29	Decoupling V2 osc. anode	5,000
41	Diode bias ptr.	3 x 23,000
42	Diode bias ptr.	2 x 7,500
43	Decoupling V4 anode	50,000
45	V4 anode I.F. coupling	35,000
48	V5 grid leak	.25 meg.
49	V5 grid decoupling	5,000
50	V4 grid leak	1 meg.
51	V5 cathode bias	1,000
52	V4 cathode bias	1,000
54	H.T. feed to V2 osc. anode	35,000
55	Gram ptr.	.23 meg.
56	Gram ptr.	150,000

(Continued in next column)

RESISTANCES (Continued)		
R.	Purpose.	Ohms.
57	Osc. "stabilising"	15,000
58	Osc. "stabilising"	2,300
59	Osc. "stabilising"	500
60	Osc. "stabilising"	150
61	A.V.C. ptr.	35 meg.
62	A.V.C. ptr.	.23 meg.
64	V5 anode stabiliser	500
65	V5 grid stabiliser	1,000
60	Decoupling A.V.C.	.75 meg.
67	V1 silencing bias	10,000
VR1	V.C.	.25 meg.
	Field coil	1200

CONDENSERS		
C.	Purpose.	Mfd.
5	Decoupling V1 grid	.05
7	V1 cathode by-pass	.1
8	V1 screen by-pass	.0003
14	Decoupling V1 anode	.1
15	Decoupling V2 grid	.05
17	H.F. by-pass across V2 heater	.002
18	V2 cathode by-pass	.1
19	V2 osc. grid reservoir	.00005
24	M.W. tracking in osc.	.00035

(Continued in next column)

CONDENSERS (Continued)		
C.	Purpose.	Mfd.
27	S.W. tracking in osc.	.00184
29	U.S.W. tracking in osc.	.00285
34	Across I.F.T.1 secondary	.001
37	Decoupling A.V.C.	.05
38	V3 cathode by-pass	.1
56	V2 aux. grid by-pass	.1
57	Decoupling H.T. to V2 osc. anode	.05
60	V4 anode decoupling	.5
62	V4 cathode by-pass	.4
63	I.F. coupling to V4 grid	.05
65	V5 grid decoupling	.1
67	H.T. smoothing	.8
68	H.T. smoothing	.8
69	Decoupling diode bias ptr.	.4
70	H.F. by-pass from diode	.00035
71	Decoupling A.V.C.	.001
73	Decoupling R 54	.4
74	Top note tone control	.0023
75	Top note tone control	.005
76	Top note tone control	.02
77	Top note tone control	.05
81	Tone control (bass) circuit	.001
82	Tone control (bass) circuit	.0015
83	Tone control (bass) circuit	.05
84	H.T. decoupling	.25
85	Decoupling V3 grid	.1
86	I.F. coupling to A.V.C.	.0001
87	Mains H.F. by-pass	.005
88	V4 cathode by-pass	.1
89	V5 anode tone compensating	.0023