

# MARCONIPHONE 855 PUSH BUTTON

**CIRCUIT.**—The input to V1, a heptode frequency changer, is by means of high Q iron-cored coils for medium and long waves, and image rejector circuits are included. Switching changes the input for automatic working to a complete press-button tuner and switch bank. The frequency changing circuit is normal, and the anode circuit of V1 contains the first I.F. transformer, which is condenser trimmed and has an iron core.

A similar transformer is used between the I.F. amplifier, V2, and the demodulation diode of the double-diode triode V3. This is resistance capacity coupled to the output valve, V4, which is provided with a negative feedback tone control circuit with variable resistance and fixed condenser connected between the anode and control grid.

All bias voltages are obtained from a common series bias resistor in the negative H.T. return, the bias resistor being in shunt with a potentiometer, by which the voltages are tapped off to the various valves.

H.T. supply is taken from a full-wave rectifier *via* conventional circuits.

The press-button unit uses fixed condensers and permeability tuned coils. No alteration is made to the 465 kc. I.F. circuits when working on push-button control.

**Chassis Removal.**—Remove the four knobs on the front of the cabinet and release the four chassis retaining bolts.

The two long bolts should be withdrawn first. The short bolts can be removed from inside the cabinet.

The multiple cable to the speaker should be released from the clip. It is long enough to permit the chassis to be withdrawn from the cabinet for minor service operations.

The speaker is withdrawn by releasing the four retaining screws and removing the extension speaker clip from the top of the cabinet.

Five self-tapping bolts enable the push-button unit to be detached. Electrical connections consist of an earth (Continued on page viii.).

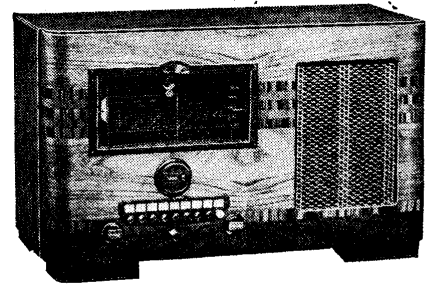

The Marconiphone model 855 is a four-valve, plus rectifier, superhet covering three wavebands and with six-station automatic tuning as well as manual. A pre-set permeability system is employed.

## CONDENSERS

C.	Purpose.	Mfds.	C.	Purpose.	Mfds.
1	Rejector condenser ..	.00005	20	V4 grid coupling ..	.023
2	L.W. input fixed trimmer ..	.00005	21	V4 bias decoupling ..	.23
3	V1 A.V.C. decoupling ..	.05	22	V4 negative feed back ..	.001
4	S.W. aerial coupling ..	.000015	23	H.T. smoothing ..	8
5	M.W. aerial top coupling ..	.0000023	24	H.T. shunt ..	.1
6	V1 osc. grid ..	.00005	25	H.T. smoothing ..	16
7	L.M. fixed padder ..	.0003	26	H.T. line decoupling ..	.4
8	M.W. fixed padder ..	.00055	27	V1 and V2 screen decoupling ..	4
9	Osc. anode coupling ..	.005	38	I.F. T.1 sec. swamp (P.U. position) ..	.0001
10	S.W. fixed padder ..	.005	42	Press-button input coupling ..	.00001
11	Osc. anode decoupling ..	4	43	Press-button fixed input tune ..	.00014
12	V1 and V2 screen shunt ..	.05	44	Push-button osc. fixed trimmer (part) ..	.00005
13	V2 A.V.C. decoupling ..	.05	45	Push-button osc. fixed trimmer (part) ..	.000015
14	A.V.C. coupling ..	.0001	46	L.W. osc. fixed trimmer ..	.000175
15	H.F. bypass ..	.0001			
16	L.F. coupling ..	.001			
17	V3 bias decoupling ..	50			
19	V3 anode shunt ..	.000035			

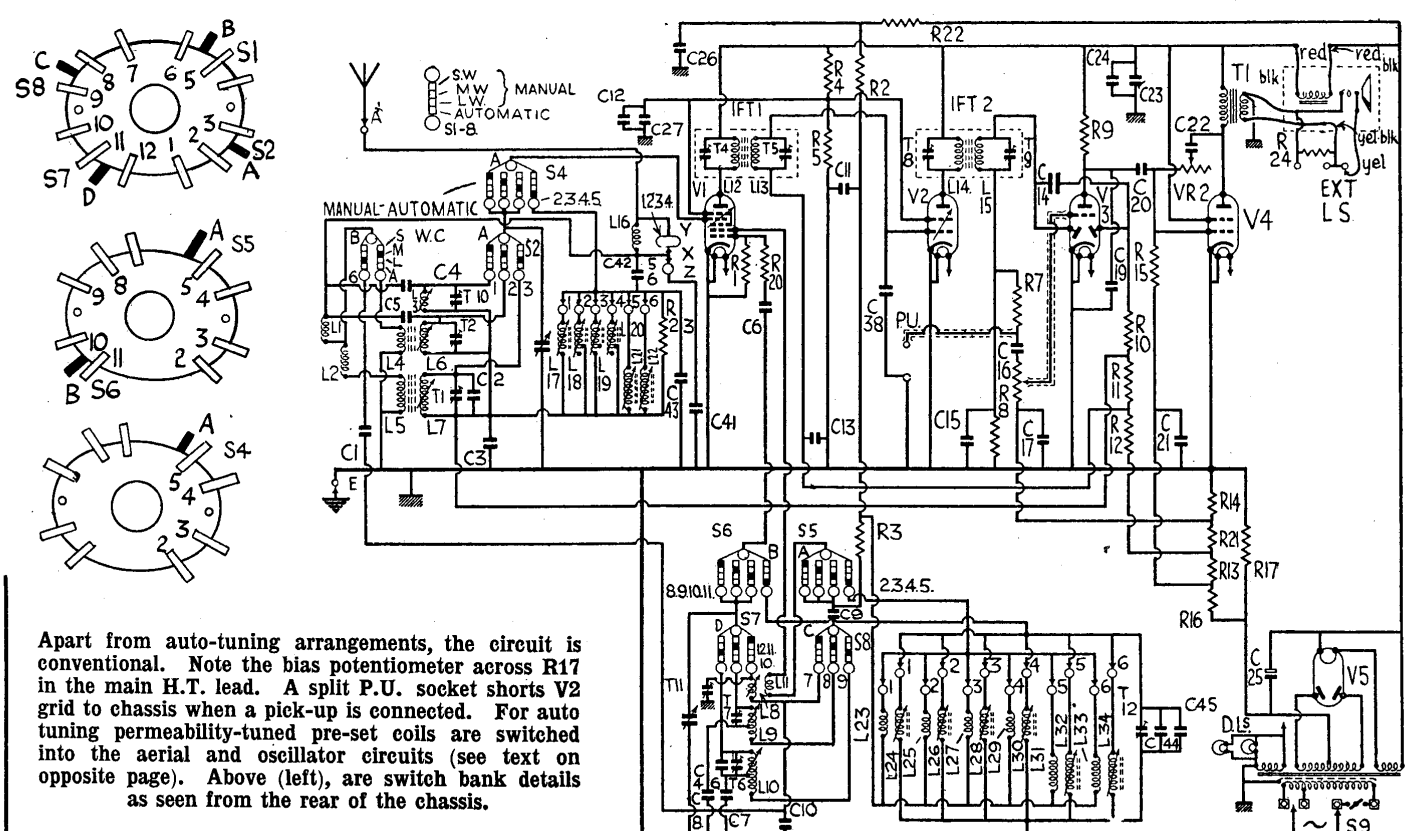

Apart from auto-tuning arrangements, the circuit is conventional. Note the bias potentiometer across R17 in the main H.T. lead. A split P.U. socket shorts V2 grid to chassis when a pick-up is connected. For auto tuning permeability-tuned pre-set coils are switched into the aerial and oscillator circuits (see text on opposite page). Above (left), are switch bank details as seen from the rear of the chassis.

## Push-button Trimmer Adjustment

**A**UTOMATIC tuning is provided in the 855 by six push-buttons providing four medium-wave and two long-wave stations. The permeability-tuned pre-set system is employed.

Certain contacts on the wave-change switch disconnect the normal tuning coils and connect the pre-set circuits. This switching is shown in the circuit diagram above the normal wave-change switching.

Each push-button is associated with two coils, one in the aerial circuit and the other in the oscillator circuit. These

coils are switched across fixed capacities (C43 in the aerial circuit and C44, C45 and T12 in the oscillator circuit) by the push-buttons. The buttons also connect the appropriate image rejector circuit (L16 or C41) for the waveband concerned.

To adjust the push-buttons proceed as follows:—

(1) Remove the panel covering the trimmers, tune in the required station and press a suitable button.

(2) Adjust first the oscillator coil screw and then the aerial coil for maximum. Shorten the aerial if tuning is too flat. Screwing trimmers in increases wavelength.

(3) Replace trimmer cover and stick new station name over old one.

Six pairs of coils are required to cover the normal medium- and long-wave ranges. One type is duplicated, so actually there are five types in the standard receiver. Three coils can be adjusted to a somewhat higher wavelength by substituting the additional lead (tied to the side of the coil) for the existing connection.

A special aerial coil for 1,700-2,000 metres is obtainable from E.M.I. Service, Ltd.

If waveranges of buttons are not realised or T12 is out of adjustment:—

(1) Connect oscillator to aerial and earth and an output meter.

(2) Fully unscrew inductance trimmer of oscillator coil for button No. 1 (L23, L24).

(3) Tune oscillator to 180 metres (1,666.7 kc.), set receiver to auto and press button 1.

(4) Adjust T12 for maximum.  
(See also Alignment Notes.)

### RESISTANCES

R.	Purpose.	Ohms.
1	Osc. grid leak .. .. .	50,000
2	Osc. decoupling .. .. .	15,000
3	Osc. feed .. .. .	15,000
4	V1, V2 screen pot. (part) ..	23,000
5	V1, V2 screen pot. (part) ..	23,000
6	Demodulating load .. .. .	500,000
7	H.F. filter .. .. .	230,000
8	Volume control .. .. .	2 meg.
9	V3 anode load .. .. .	75,000
10	A.V.C. diode load (part) ..	1 meg.
11	A.V.C. diode load (part) ..	500,000
12	A.V.C. diode load (part) ..	2.3 meg.
13	Bias pot. part .. .. .	1 meg.
14	Bias pot. part .. .. .	100,000
15	V4 grid leak .. .. .	230,000
16	Bias pot. part .. .. .	100,000
17	Series bias .. .. .	270
20	Osc. grid suppressor .. .. .	20
21	Bias pot. part .. .. .	100,000
22	H.T. line volt drop .. .. .	5,000
23	Push-button input shunt ..	2.3 meg.
24	Speech coil load .. .. .	50
25	Tone control .. .. .	2 meg.

## Marconi 855 on Test

**M**ODEL 855.—For A.C. mains, 195-225 volts, 50-100 cycles. Price, 13½ gns.

**DESCRIPTION.**—Four-valve, plus rectifier, three-waveband manual and press-button model, using pre-set inductance system.

**FEATURES.**—Full-vision scale with horizontally travelling pointer and a vernier scale visible through slot. Controls for tuning, volume with master switching, tone, and wave selection, including auto-position. Six press-buttons, two for long waves, controlling pre-set inductances. Sockets for aerial, earth, pick-up and extension speaker.

**LOADING.**—65 watts.

### Sensitivity and Selectivity

**SHORT WAVES** (16.5-50 metres).—Good gain and selectivity, with well-maintained sensitivity over the whole band. Easy handling.

**MEDIUM WAVES** (195-580 metres).—Excellent selectivity and gain, with clean background. Local station spread on adjacent channels only.

**LONG WAVES** (900-2,000 metres).—Excellent selectivity and good sensitivity. All main stations easily received and very little side splash on Deutschlandsender.

### Acoustic Output

Ample volume for an ordinary room, with very pleasing tone. Attack is crisp and clean and the medium and low registers radiate well. Orchestral balance is pleasing and there is little colouration on speech.

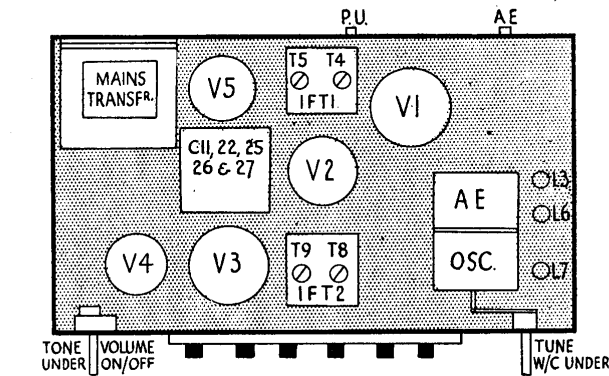

Left, the top of the chassis is very clean and logical with only the I.F. coils in view. Below, the layout diagram identifying parts below the chassis. Most of the coils are un-screened and mounted on two strips by the wavechange switch rod. Auto tuning components are on a separate assembly.

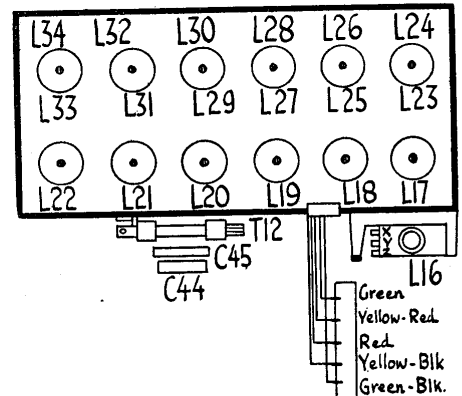
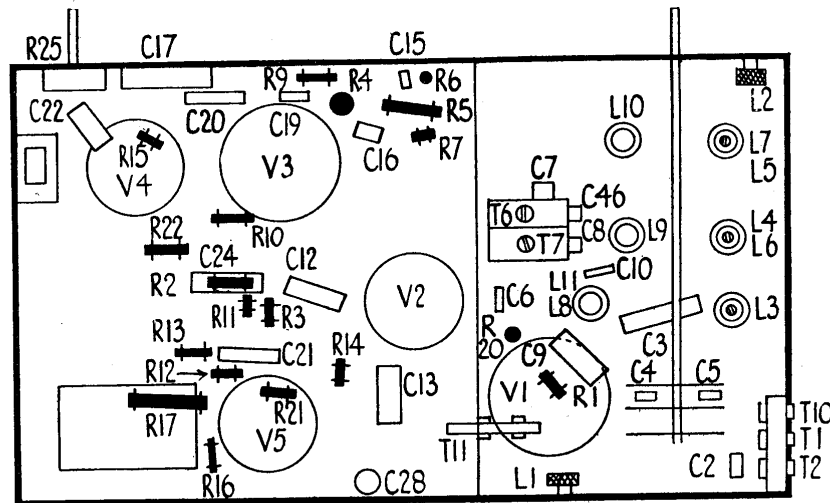
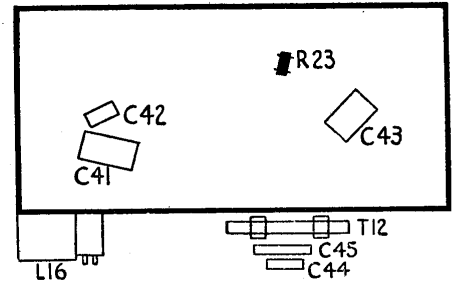

These diagrams show the two sides of the push-button switch, coil and trimmer unit. Details of the switch side of the assembly are given in the top drawing.

# Marconiphone Push-button 855

(Continued from page vi.)

lead, five colour coded leads and two leads to a small switch on the side. The cover for the main tuning pack can be withdrawn by removing three self-tapping bolts.

**Special Notes.**—The condensers C41 and C45 and the resistance R23 are on the upper side of the special switch in the press-button coil unit and are only accessible by removing the cover. Certain of the condensers in the coil unit are not very accessible. Should it ever be necessary to remove these the padder must also be released.

It should be particularly noted that the 16 mfd. condenser has two insulated leads, as the negative H.T. line does not return to the chassis. This condenser is the first smoothing unit, and the second smoothing condenser is in the condenser block with the negative side returned to chassis.

It will also be noted that no cathode bias resistors are used, all bias being derived from a potentiometer consisting of a network of resistances across a common 270-ohm resistance, R17. The 50-ohm resistor across the speaker is located at the back of the extension speaker socket.

The "earthy" socket of the pick-up is a split type. Insertion of the pick-up plug joins the two halves of the socket and puts into circuit a fixed condenser which detunes the first I.F. transformer, thereby preventing radio breakthrough.

## Circuit Alignment Notes

In carrying out ganging operations, the input to the receiver from the oscillator must be kept low and progressively reduced as the circuits are brought into line, so that the output meter reading does not exceed 50 mw. or 0.45 volt with the receiver volume control at maximum.

The output meter should be connected between the anode of V4 (KT63) and chassis. If an A.C. voltmeter is used it must be connected across the L.S. speech coil.

**I.F. Ganging.**—Switch receiver to L.W., set gang condenser to maximum capacity, volume control to maximum, and tone control to maximum top (fully anti-clockwise).

Tune oscillator to 465 kcs. (654.2 metres) and connect output leads to fixed vane tag of VC1 (via a 0.1 mfd. condenser) and to chassis, leaving grid lead connected to V1 and the cap in place.

- (1) Switch on receiver and oscillator.
- (2) Adjust T4, T5, T8 and T9 in that order for maximum output.
- (3) Check adjustment in the same order.

**Medium Waves.**—Set receiver to M.W., volume to maximum and tone control fully anti-clockwise. Connect oscillator to aerial and earth sockets.

It is essential that before ganging, the position of the pointer is checked. Turn the gang condenser to maximum and adjust the pointer to coincide exactly with

the small mark which will be found at the bottom right-hand corner of the scale. All ganging is now done to settings on the scale itself, and the gang condenser must not be rocked, or the positioning of the pointer altered in any way.

(1) Set receiver (by spot on scale) and oscillator to 225 metres (1,335.3 kcs.).

(2) Adjust T7 for maximum output.

(3) Set receiver (by spot on scale) and oscillator to 530 metres (566 kcs.).

(4) Adjust spade trimmer of L9 for maximum output.

(5) Repeat operations 1, 2, 3 and 4.

(6) Repeat operations 1 and 2.

(7) Tune receiver (by scale) and oscillator to 225 metres.

(8) Adjust T2 for maximum.

(9) Tune receiver (by scale) and oscillator to 530 metres.

(10) Rotate upper core of L6 for maximum by means of the special tool (obtainable for E.M.I. Service, Part No. 20730A), which consists of a pointed rod of insulating material with a rubber bush.

It should be inserted through the hole in the chassis, the point located in the hole in the paxolin coil mounting strip, and the rubber bush bearing on the core. The core may now be rotated by turning the tool.

(11) Repeat operations 7 and 8.

**Long Waves.**—Switch receiver to L.W., volume and tone controls as for M.W.

(1) Set receiver (by scale) and oscillator to 1,100 metres (272.7 kcs.).

(2) Adjust T6 for maximum output.

(3) Set receiver (by scale) and the oscillator to 1,900 metres (158 kcs.).

(4) Adjust L10 for maximum.

(5) Repeat operations 1, 2, 3 and 4.

(6) Repeat operations 1 and 2.

(7) Adjust T1 for maximum output (1,100 metres).

(8) Set receiver (by scale) and the oscillator to 1,900 metres.

(9) Adjust hexagonal-headed screw core for L7 for maximum.

(10) Set oscillator and receiver (by scale) to 1,400 metres (214.3 kcs.).

(11) Readjust T1 for maximum output.

**Short Waves.**—The trimmers used for the S.W. oscillator circuit (T11) and the

## WINDINGS (D.C. RESISTANCES)

L.	Ohms.	Range.	Where measured.
1 .. .. .	9.5	S.W.	S1 and (L16+C42)
2 .. .. .	33	—	S1 and (L2+L5)
3 .. .. .	.1	S.W.	Grid V1 and C3
4 .. .. .	.4	—	Chassis and S1-5
5 .. .. .	1.6	—	Chassis and (L3+L2)
6 .. .. .	2	M.W.	Grid V1 and C3
7 .. .. .	9	L.W.	Grid V1 and C3
8 .. .. .	.1	S.W.	S7-10 and S8-7
9 .. .. .	2.8	M.W.	S7-11 and S8-8
10 .. .. .	3.6	L.W.	S7-12 and S8-9
11 .. .. .	1.2	S.W.	S5 and osc. anode.
12 .. .. .	4.5	—	Anode V1 and HT plus.
13 .. .. .	4.5	—	Grid V2 and C13
14 .. .. .	4.5	—	Anode V2 and HT plus.
15 .. .. .	4.5	—	Demodulating diode and R6 and R7.
O.T. prim.	288	—	Anode V4 and HT plus.
M.T. prim.	25	—	Mains plug.
Field ..	1660	—	Red and red-black leads.

push-button oscillator circuit are of a special type. Adjustment is done as follows:—

(a) Slightly slacken the hexagonal lock-nut (sufficiently for the rod to be moved up or down with a piece of bent wire).

(b) Slide rod up or down to adjust, and tighten lock-nut.

For short-wave ganging the oscillator output should preferably be terminated with a 100-ohm non-inductive resistance in parallel, and a 400-ohm non-inductive resistance in series with the "hot" lead.

(1) Set receiver (by scale) and oscillator to 16.5 metres (18.2 mcs.).

(2) Adjust T11 and T10 for maximum output.

(3) Set receiver and oscillator to 50 metres (6 mcs.) and adjust inductance loops of L8 and L2 for maximum output. These loops are accessible through holes, and a strip of insulating material with a slot in it should be used to move the wire up or down.

(4) Repeat operations 1 and 2.

(5) Repeat operation 3 if necessary.

(6) Repeat operations 1 and 2.

Do not alter the position of the pointer after ganging.

Do not "rock" the gang condenser.

## Replacement Condensers

**E**XACT replacement condensers are available from A. H. Hunt, Ltd., Garratt Lane, Wandsworth, London, S.W.18, for two units in the 855. For the block containing Cs. 25, 24, 26, 27 and 11, there is unit list number 4268, price 12s. 6d., and for C17, unit 2915, 1s. 9d.

## Leaky Speaker Strip

**H**ERE is a most unusual fault. A receiver came in, the trouble being that after it had been running about 20 minutes severe distortion accompanied by a frying noise occurred.

None of the usual tests revealed the cause, and it was not until I was at my wits' end that the trouble was found. The insulation of the speaker terminal strip had broken down and arcing was occurring between two tags. The leak in the strip seemed partly due to soldering flux having saturated the material.—THOMAS W. NELLIST, Edinburgh.

## QUICK TESTS

Quick tests are available on this set between the chassis and the speaker strip.  
Chassis and red, 235 volts, smoothed H.T.  
Chassis and red-black, 340 v., unsmoothed H.T.

## VALVE READINGS

V.	Type.	Electrode.	Volts.	Ma.
1	All Marconi X63 ..	Anode ..	235	2
		Screen ..	80	2.5
		Osc. anode ..	—	—
2	KTW 63 ..	Anode ..	235	5
		Screen ..	80	1
3	DH 63 ..	Anode ..	130	1
		Screen ..	225	36
4	KT63 ..	Anode ..	235	6
		Screen ..	235	—
5 Pilot lamps	U50 Osram ..	Heater ..	340	—
		—	6.5	300