

MURPHY A34, A34RG

Three-valve, plus rectifier and tuning indicator, superhet covering medium and long waves. Marketed in 1938 by Murphy Radio, Ltd., Welwyn Garden City, Herts.

Circuit.—The aerial is coupled to V1, the frequency-changer by a band-pass circuit on both the wavebands. L5 and L6 provide inductive coupling and C8 decouples the A.V.C., which is applied to V1 via the grid coils.

The aerial itself is connected down to chassis via LO and CO, coupled to the grid circuit so as to provide image suppression.

The triode oscillator section of V1 is used so as to modulate the cathode emission of the mixer section, i.e., the reaction windings are included in the cathode circuit.

The oscillator tuned coils are connected directly in the anode line, although the condensers go down to chassis and, therefore, have the H.T. across them.

R3 and R4 bias the mixer section of V1, but the oscillator section develops its own bias across the grid leak and

condenser, R2 and C10, which are returned to the top end of the bias components.

V1 anode circuit includes a trimmer-tuned I.F. transformer and decoupling components R6, C14.

V2 is the I.F. amplifier with minimum bias by R9 and A.V.C. via R11 (decoupled by C20). In the radiogram model, the pick-up is included in the grid circuit of V2.

On gramophone R4 is brought into the cathode of V1, producing a high bias which stops the valve operating. R8 is brought into the feed of V2 screen, which performs as an anode. Amplified I.F. developed by R8 is passed by C26 to the volume control (R19), and hence to the grid of V3.

For radio, R8 is shorted out and the I.F. is passed by a second I.F. transformer to V3. R19, the volume control, is the signal diode load. R16 with C28 and C29 forms an I.F. filter. L.F. is passed by C30 to the grid of V3 via a stabiliser R23.

The potentiometer R17-R18 taps off a proportion of the rectified D.C. across R19, to operate V5, the cathode-ray type tuning indicator. It will be seen that the maximum demodulated D.C. can be applied via R15, and a switch to a screen of V2. This arrangement forms an inter-station noise suppressor.

The cathode of V3 is biased by R24

and R25, but only the drop across R24 is applied to the pentode section.

Energy for A.V.C. is taken from V2 anode by C25, and the control voltage developed across R12 and R13.

The anode circuit of V3 contains a heterodyne whistle filter and a switched resistance R26, which modifies the tone on gramophone. R21 and C35 form a variable tone control across the speaker.

H.T. is derived from a full-wave rectifier, with the smoothing choke, L13, which is the speaker field, in the negative lead.

The extension speaker should be a low impedance of 2-4 ohms and in the radiogram the pick-up has a D.C. resistance of 4,500 ohms.

GANGING

I.F. Circuits.—Tune to 2,000 m. Inject 119 kc. to V1 signal grid and adjust the four I.F. trimmers for maximum on an output meter, reducing the input as the circuits coming into line to keep below point at which A.V.C. operates.

M.W. Band.—Tune to frequency of a known broadcast signal near to 220 m. Adjust T1 for maximum volume on station judged by ear or tuning indicator.

Disconnect aerial and connect oscillator via dummy aerial. Adjust oscillator for maximum signal on output meter, ignoring actual calibration. Adjust T2 for maximum. Adjust T3.

Continued in end column

Layout diagram of the underside of the Murphy chassis indicating the positions of the trimmers, switches and other main components.

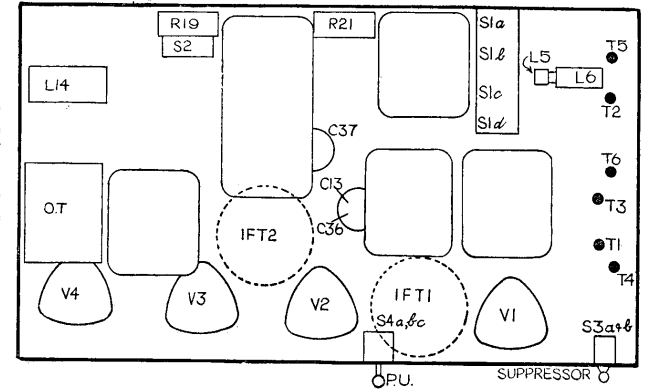

VALVE READINGS

V.	Type	Electrode	Volts
1	AC/TP	Anode	168
		Screen	160
		Cathode	3.8
2	AC/VP2	Osc. Anode	80
		Anode	235
		Screen	220
3	AC/2PenDD	Cathode	2.5
		Anode	210
		Screen	235
4	UU4	Cathode	16
		Anode	350
5	AC/ME	Anode	235
		Cathode	40

Repeat T2 and T3 adjustments.
L.W. Band.—The above method of using a broadcast station as a known frequency may be used. Alternatively

Continued end column, opposite page

CONDENSERS

C.	Mfds.	C.	Mfds.
CO	.0095	25	.00005
8	.1	26	.05
9	.00035	27	.05
10	.0005	28	.0001
11	.05	29	.0002
12	.001	30	.005
13	.8	31	.002
14	.01	32	.0003
19	.001	33	.002
20	.05	34	.25
21	.1	35	.04
22	.05	36	.8
23	.05	37	.8
24	.01	38	.2

RESISTANCES

R.	Ohms	R.	Ohms
1	5,000	14	2 meg.
2	50,000	15	1 meg.
3	500	16	100,000
4	20,000	17	2 meg.
5	100,000	18	1 meg.
6	5,000	19	500,000
7	100,000	20	1 meg.
8	50,000	21	50,000
9	300	22	1 meg.
10	3,000	23	5,000
11	1 meg.	24	140
12	800,000	25	320
13	600,000	26	10,000

WINDINGS

L.	Ohms	L.	Ohms
0	.1	12	.8
1	1.2	13	2,250
2	.9	14	360
3	.4	15	40
4	.12	16	40
5	.3	17	40
6	.2	18	40
7	.4	19	40
8	.12	20	27-34
9, 10	2.5	21	.1
11	3.5		

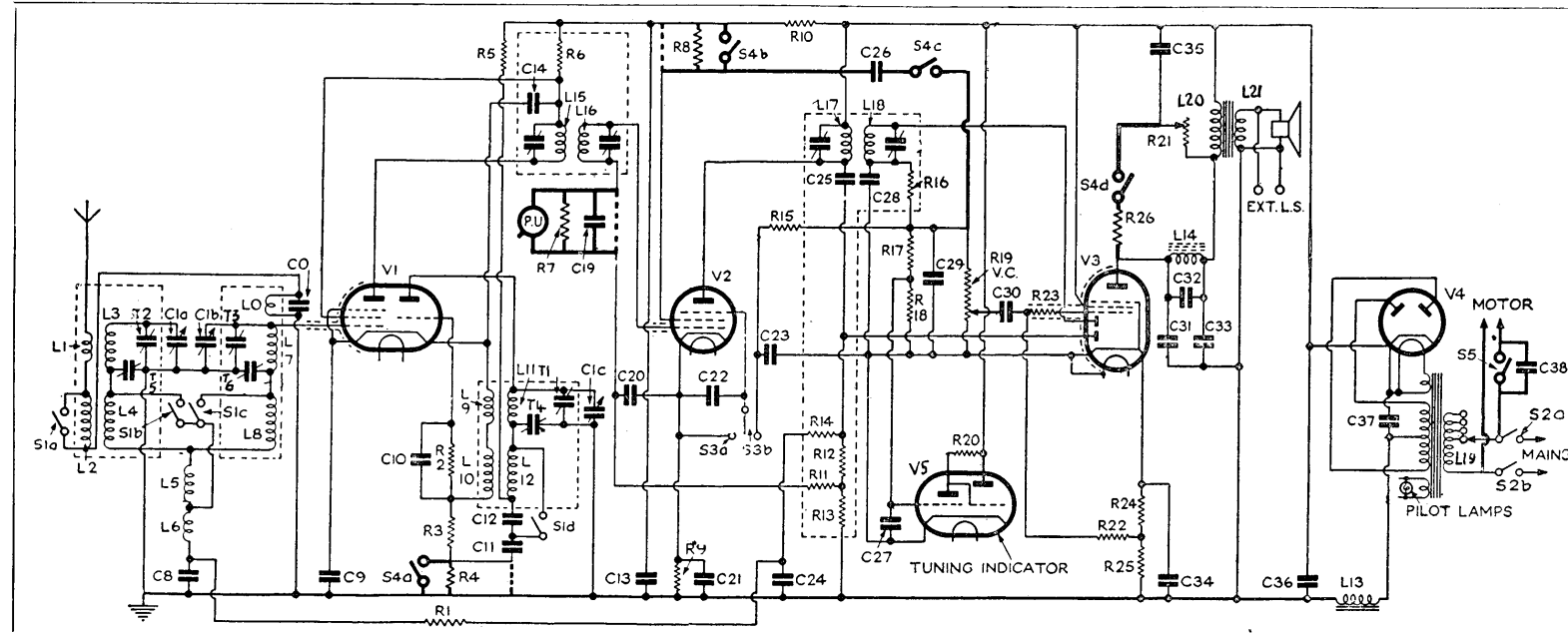

MURPHY —Continued from opposite page

for both bands the conventional system may be used as follows :—

Tune to 1,500 m., inject 1,500 m. and adjust T4.

Tune to 1,000 m., inject 1,000 m., and adjust T5 and T6 until no further improvement results.

Image Filter.—Inject powerful 333 m. signal to aerial and earth. Tune to 453 m. or thereabouts where image is heard.

With insulated screwdriver, adjust erinoid screw on top of band-pass secondary coil for minimum signal.