

"TRADER" SERVICE SHEET
1413

MURPHY A272

A.M./F.M. Table Receiver for A.C. Mains Operation

THE Murphy A272 is a five-valve (plus rectifier) A.M./F.M. table receiver housed in a wooden cabinet and designed to operate from A.C. mains of 200-250V, 50-100c/s. Total mains consumption is approximately 53W. It employs an internal F.M. aerial, which may also be used for local station reception on the A.M. bands. The wavebands covered are 87.5-100 Mc/s (F.M.), 187-568m (M.W.) and 1,200-2,000m (L.W.). Provision is made for the connection of external aerials, a gramophone pick-up and a low impedance external speaker.

The A272C is a console version of the A272, employing a baffle form of cabinet construction. Differences between chassis used in these models are described under "Model A272C" overleaf.

Release dates and original prices: A272, September 1957, £22 6s; A272C, August 1956, £27 17s 6d. Purchase tax extra.

CIRCUIT DESCRIPTION

For A.M. operation, external A.M. aerial is coupled via L11, C17 to tuned circuits L12, C19, C21 (M.W.) and L13, C18, C21 (L.W.) which precede triode-heptode frequency changer V2.

Triode section a of V2 operates as a tuned anode oscillator with M.W. reaction coil L15 tuned by C28, C31, C32. Series tracking by C25. For L.W. operation, L15 and L16 are connected in series and tuned by C28, C29, C30, with additional series tracking by C27.

Variable-mu R.F. amplifier V3 is em-

ployed as intermediate frequency amplifier with tuned A.M. transformer couplings L19, L20; L24, L25.

A.M. intermediate frequency 470kc/s.

Diode section c of triple-diode-triode valve V4 is employed as detector. The audio frequency component in its rectified output is developed across R18, and is passed via S19, volume control R20, and C52 to the control grid of the grid current biased A.F. amplifier V4d. I.F. filtering by R15, C49.

The D.C. potential developed across R18 is fed back via decoupling components R16, C40 and R9, C20 to the control grid circuits of V2b and V3, giving automatic gain control.

Resistance-capacitance coupling by R23, C58 and R25 between V4d anode and tetrode output valve V5. Tone correction by C60, R27, and by negative feedback between T1 secondary winding and the input circuit of V4d via R30, R31, C62, R32. Tone control in V4d anode circuit by R24, C55.

H.T. current is supplied by full-wave rectifying valve V6. Smoothing by electrolytic capacitors C59, C57; R29, and winding a on output transformer T1.

Operation on F.M.

80Ω balanced aerial input via oscillator radiation filter L1, L2, C1 and aerial coupling transformer L3, L4 to the earthed-grid R.F. amplifier V1a. The output of V1a is developed across capacitively tuned circuit L5, C3, C4 and coupled via C6, L6 to the control grid of the self-oscillating frequency changer V2.

Tuned oscillator reaction circuit is formed by C8, L7, C10 and variable tuning capacitor C11. To minimize local oscillator radiation via the R.F. and aerial circuits, a bridge neutralizing circuit is formed by C7, L6 tapping, together with the input capacitance of V1b, and the R.F. output from V1a is connected to the point of minimum oscillator potential at the tapping on L6.

V2b and V3 operate in a conventional I.F. amplifier circuit with tuned F.M. transformer couplings L9, L10; L17, L18; and discriminator transformer L21, L22 and L23. To prevent excessive damping of the first F.M. I.F. transformer primary winding L9, a small amount of positive feedback is applied from the anode to the grid circuit of V1b. A.M. oscillator section a of V2 is muted on F.M. by opening S10.

F.M. intermediate frequency 10.7Mc/s.

Diode sections a and b of V4 are employed in an unbalanced ratio detector circuit. Tertiary winding L23 is connected to the capacitive centre tap at the junction of C42, C43. A.F. output is taken from one side of L22, and fed via de-emphasis circuit R14, C44; C48, S18 and volume control R20 to the control grid of A.F. amplifier V4d.

CIRCUIT ALIGNMENT

Equipment Required.—An A.M. signal generator covering the range 150kc/s to 100Mc/s, modulated 30 per cent at 400c/s; an A.C. voltmeter for use as A.F. output meter; a 20,000Ω/V D.C. voltmeter or D.C. valve voltmeter for use as D.C. output meter; an R.F. valve voltmeter; two matched 100kΩ

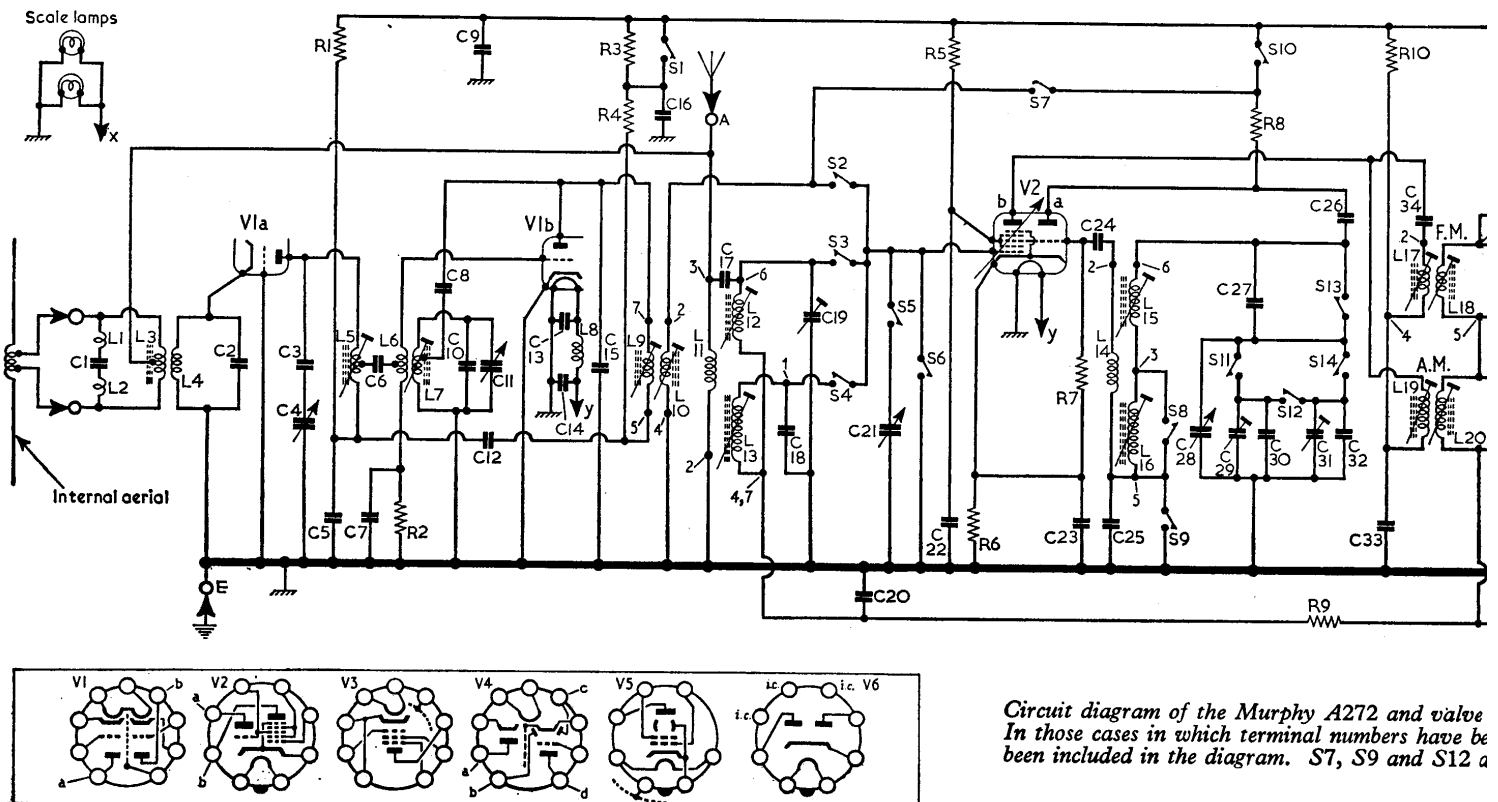

Circuit diagram of the Murphy A272 and valve pinout diagrams. In those cases in which terminal numbers have been included in the diagram, S7, S9 and S12 are also shown.

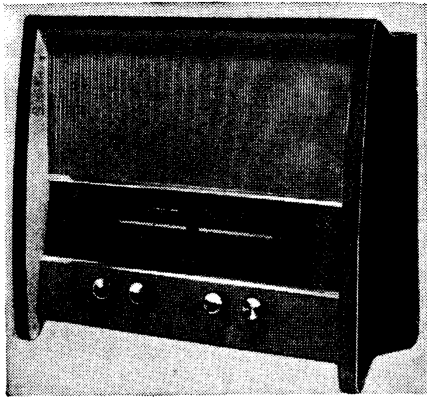

Appearance of the Murphy A272.

resistors; a 2.2kΩ resistor and a 0.01μF capacitor connected in series for use as a damping unit; a 0.01μF capacitor; an 80Ω resistor; and a non-metallic screwdriver-type trimming tool.

As the tuning scale remains fixed to the cabinet when the chassis is removed for alignment purposes, an alignment tuning scale, calibrated in centimetres, is fixed beneath the lower edge of the tuning scale backing plate.

In the A272, a rearward bend in the crank in the centre of the bottom limb of the cursor assembly is used as a pointer, while for model A272C the rim of the eyelet on the drive cord is used as the pointer.

For A.M. alignment, adjust the signal generator attenuator so that the reading on the A.F. output meter does not exceed 0.7V. For F.M. alignment, adjust it so that the reading on the D.C. output meter is maintained as near as possible to 8V without the damping unit in circuit, or 4V with it.

Except where otherwise indicated, adjust the cores of all coils for the first peak ob-

tained from the adjusting end of the coil former.

A.M. Alignment

- 1.—Remove the chassis from the cabinet. Stand the chassis on the mains transformer end and check that with the tuning gang at maximum capacitance the tuning pointer coincides with 5.5 (A272) or 5.0 (A272C) on the centimetre tuning scale.

- 2.—Connect the A.F. output meter to the external speaker sockets (A272) or to T1 secondary winding (A272C). Connect signal generator via the 0.01μF capacitor to V3 control grid (pin 2).

- 3.—Switch receiver to M.W. and turn the gang to maximum capacitance. Unscrew the cores of L19, L20 (C1) and L24 (B1).

(Continued overleaf col. 1)

COMPONENT VALUES AND LOCATIONS

Resistors			Capacitors		
R1	10kΩ	H4	R31	6.8kΩ	A2
R2	220kΩ	C2	R32	150Ω	F4
R3	470kΩ	G3			
R4	4.7kΩ	H4			
R5	27kΩ	F4			
R6	150Ω	G3			
R7	68kΩ	C2			
R8	220kΩ	F4			
R9	1MΩ	H4			
R10	4.7kΩ	F4			
R11	39kΩ	F4			
R12	82Ω	F4			
R13	3.3kΩ	F4			
R14	100kΩ	F4			
R15	100kΩ	F4			
R16	1.5MΩ	G4			
R17	330Ω	E4			
R18	470kΩ	F4			
R19	18kΩ	E4			
R20	500kΩ	F3			
R21	10MΩ	E4			
R22	100kΩ	E4			
R23	150kΩ	E4			
R24	250kΩ	E3			
R25	470kΩ	E4			
R26	22kΩ	E4			
R27	5.6kΩ	A2			
R28	220Ω	E4			
R29	†1.35kΩ	A2			
R30	1.8kΩ	A2			
			C1	22pF	C1
			C2	18pF	D1
			C3	56pF [‡]	C1
			C4	17pF [‡]	C1
			C5	500pF [‡]	D1
			C6	82pF [‡]	D1
			C7	3.3pF [‡]	C2
			C8	10pF [‡]	D2
			C9	1,800pF	H4
			C10	22pF [‡]	C1
			C11	17pF [‡]	C2
			C12	0.005μF	H4
			C13	0.001μF	D2
			C14	0.001μF	D2
			C15	5pF [‡]	D2
			C16	1,800pF	H4
			C17	2.7pF [‡]	H4
			C18	120pF [‡]	H4
			C19	40pF	H3
			C20	0.04μF	H4
			C21	528pF [‡]	C2
			C22	0.01μF	F3
			C23	0.04μF [‡]	G4
			C24	68pF [‡]	F3
			C25	520pF [‡]	F3
			C26	100pF [‡]	F3
			C27	390pF	G3
			C28	528pF [‡]	C1
			C29	40pF	G3
			C30	140pF [‡]	G4
			C31	40pF	F3
			C32	15pF	F3
			C33	0.01μF	G4
			C34	100pF [‡]	F4
			C35	10pF [‡]	C1
			C36	100pF [‡]	F4
			C37	0.01μF	F4
			C38	0.04μF	F4
			C39	0.01μF	F4
			C40	0.04μF	F4
			C41	15pF [‡]	B2
			C42	100pF [‡]	B2
			C43	100pF [‡]	B2
			C44	220pF	F4
			C45	100pF [‡]	B1
			C46	180pF	B1
			C47	100pF	F4
			C48	0.04μF	F4
			C49	100pF	F4
			C50	470pF	F4
			C51	5μF	E4
			C52	0.02μF	E4
			C53	0.1μF	E4
			C54	1,800pF	F4
			C55	0.04μF	E3
			C56	0.001μF [‡]	E4
			C57	50μF	G4
			C58	0.005μF	E4
			C59	50μF	G4
			C60	0.01μF	A2
			C61	50μF	E4
			C62	0.25μF	A2
			C63	470pF	B2
			C64	470pF	B2

If the component numbers in these tables are used when ordering spare parts, dealers are requested to mention the fact on the order, as these numbers may differ from those used in the manufacturers' service manual.

Coils*		
L1	—	D1
L2	—	D1
L3	—	D1
L4	—	D1
L5	—	C1
L6	—	C2
L7	—	D2
L8	—	D2
L9	1.5	D2
L10	1.4	D2
L11	51.0	D1
L12	2.7	D1
L13	30.0	D1
L14	—	C2
L15	5.0	C2
L16	9.5	C2
L17	1.5	C1
L18	1.5	C1
L19	13.6	C1
L20	13.6	C1
L21	1.3	B1
L22	—	B1
L23	—	B1
L24	15.0	B1
L25	10.0	B1
L26	3.0	—

Miscellaneous*		
T1	{ a 13.8 b 475.0 c — d — e —	A2
T2	{ a 140.0 b — c 146.0 d 26.5 (total)	A2
S1-S20	—	G3
S21, S22	—	E3

*Approximate D.C. resistance in ohms.
†Two 2.7kΩ in parallel.
‡Swing value.
±0.5pF.
1%
2%
5%
10%
15%
20% Negative temperature coefficient.
25% Negative temperature coefficient.
10%.

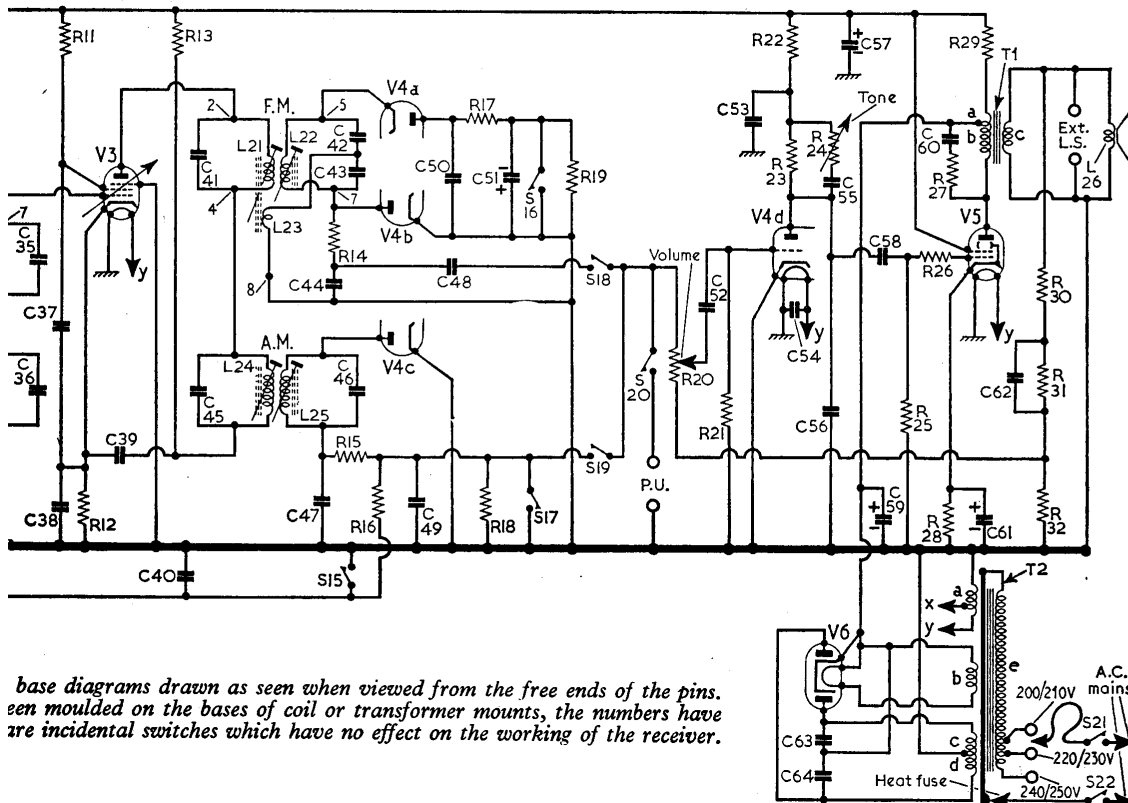

base diagrams drawn as seen when viewed from the free ends of the pins. When moulded on the bases of coil or transformer mounts, the numbers have incidental switches which have no effect on the working of the receiver.

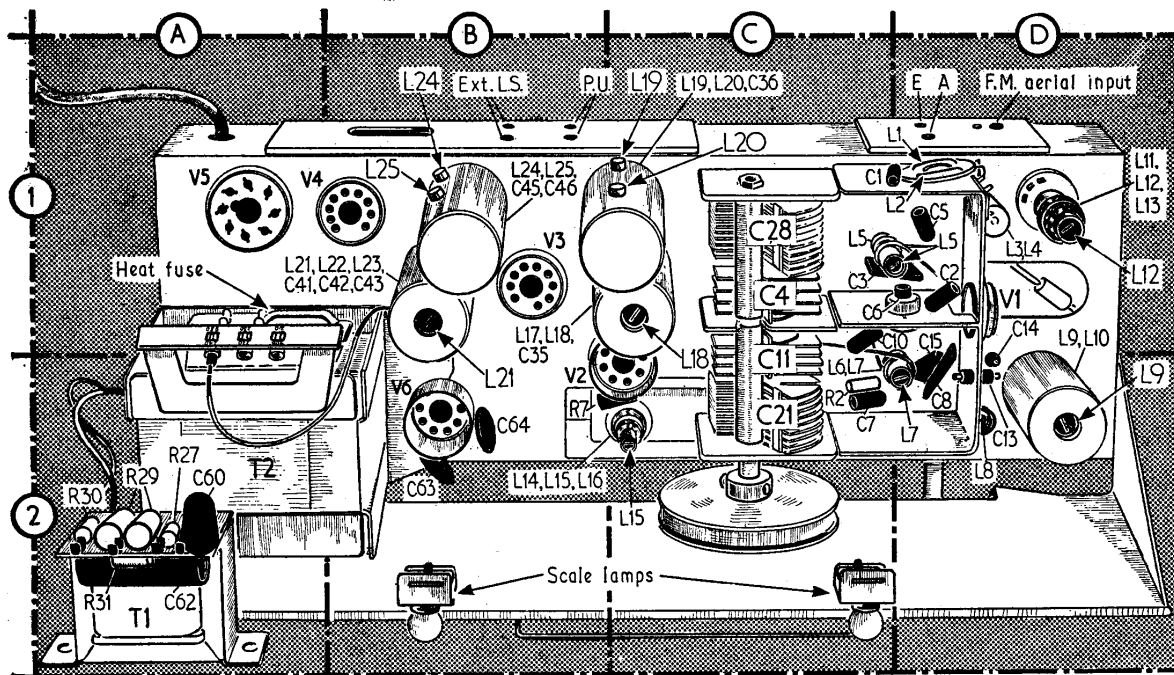

Plan view of the chassis. T1 is fitted behind the front of the cabinet.

Circuit Alignment—continued

- Feed in a modulated 470kc/s signal and adjust the cores of L25 (B1) and L24 for maximum output. Do not readjust L25.
- Transfer the signal generator, still via the 0.01μF capacitor, to C19 (H3). Feed in a modulated 470kc/s signal and adjust the cores of L20 and L19 (C1) for maximum output. Do not readjust L20.
 - Transfer signal generator output, via a dummy aerial, to the A.M. aerial socket. With the receiver still switched to M.W., tune it to 7.3 (A272) or 6.8 (A272C). Feed in a modulated 600kc/s signal and adjust the cores of L15 (C2) and L12 (D1) for maximum output.
 - Tune the receiver to 13.65 (A272) or 13.15 (A272C). Feed in a modulated 1,364kc/s signal and adjust C31 (F3) and C19 (H3) for maximum output.
 - Repeat operations 5 and 6.
 - Switch receiver to L.W. and tune it to 8.25 (A272) or 7.75 (A272C). Feed in a modulated 176.5kc/s signal and adjust L16 (F3) for maximum output, then ad-

just L13 (H4) to the second peak obtained from the adjusting end of the coil former.

- Tune the receiver to 14.55 (A272) or 14.05 (A272C). Feed in a modulated 300kc/s signal and adjust C29 (G3) for maximum output. Disconnect signal generator and A.F. output meter.

F.M. Alignment

- Connect the D.C. output meter, switched to its 10V range, across C51 (E4), positive terminal to chassis. Connect signal generator via the 0.01μF capacitor to V1a cathode (pin 3).
- Switch the receiver to F.M. Turn tuning gang to maximum and volume control to minimum. Feed in an unmodulated 10.7Mc/s signal and adjust L21 (B1) for maximum output. Adjust the signal generator attenuator to obtain an 8V reading exactly on the D.C. output meter, then disconnect the D.C. output meter.
- Connect the two matched 100kΩ resistors in series across C51 (E4). Set the pointer of the meter accurately to zero, then connect it between C44 (F4) and the junction

of the two 100kΩ resistors. Without altering the signal generator attenuator setting, adjust L22 (F4) for a zero reading exactly on the D.C. output meter. Disconnect the meter and the 100kΩ resistors.

- Reconnect the D.C. output meter across C51, positive terminal to chassis. Connect the damping unit between chassis and the junction of L17, C34 (F4). Feed in an unmodulated 10.7 Mc/s signal and adjust L18 (C1) for maximum output, progressively adjusting the signal generator attenuator to maintain a 4V reading on the D.C. output meter.
- Transfer damping unit to V3 control grid (pin 2) and chassis. Feed in an unmodulated 10.7 Mc/s signal and adjust L17 (F4) for maximum output, while still maintaining a 4V reading on the D.C. output meter.
- Disconnect damping unit and re-check setting of L21 core.
- Connect damping unit between chassis and V1b anode (pin 6). Feed in an unmodulated 10.7 Mc/s signal and adjust L10 (H3) for maximum output.
- Transfer damping unit to L10. Feed in an unmodulated 10.7 Mc/s signal and adjust L9 (D2) for maximum output. Disconnect damping unit and signal generator.
- Connect signal generator, terminated with the 80Ω resistor, to the F.M. aerial sockets. Tune receiver to 8.65 (A272) or 8.15 (A272C). Feed in an unmodulated 91 Mc/s signal and adjust L7 (D2) and L5 (D1) for maximum output, then disconnect signal generator.
- In early versions of the A272C, C7 is a pre-set oscillator neutralizing capacitor (see "Model A272C" col. 4). To adjust the neutralizing capacitor, connect the R.F. valve voltmeter, switched to its 1V range, between V1a anode (pin 1) and chassis. Tune the receiver to 11.2 and adjust the neutralizing capacitor for minimum reading (dip between two peaks) on the R.F. valve voltmeter. Then disconnect the valve voltmeter and re-adjust L7 as explained in operation 9.

- After replacing the chassis in its cabinet, set the gang to maximum and see that the right-hand edges of the cursors (A272) or their centres (A272C) coincide with the right-hand ends of the tuning scale apertures.

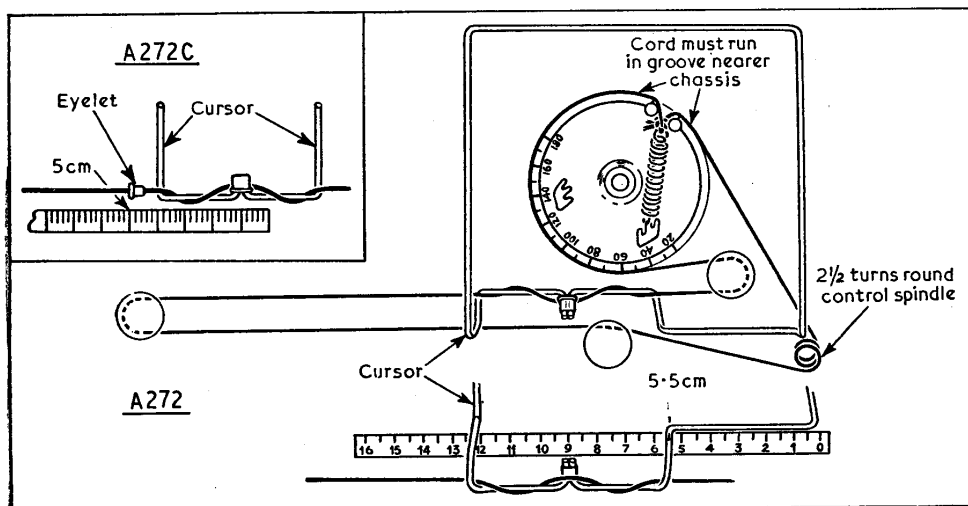
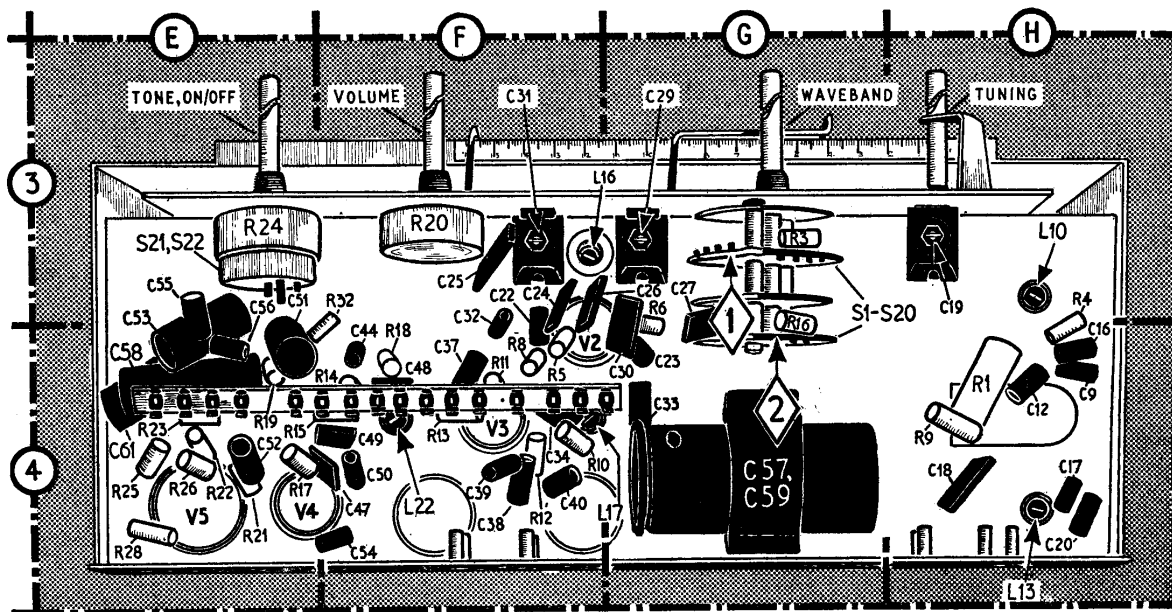

Diagram of the tuning device system. The inset diagram shows how the alignment scale and cursor of model A272C differ from those of model A272.

Underside view of the chassis. The alignment scale is seen fitted to the lower edge of the tuning scale reflector. Its use is made clear under "Circuit Alignment" and in the diagram at the foot of cols. 1 and 2.



MODEL A272C

The differences in the original design of the A272C as compared with the A272 are that it is provided with a switch to mute the external speaker and that R30, R31 and C62 in the feedback circuit are replaced by a 1.5kΩ resistor. In early versions, too, C7 was a 3-9pF pre-set capacitor, and its adjusting screw was located just to the rear, and to the right, of the waveband switch unit. Its adjustment is explained in operation 10 under "F.M. Alignment." In addition C47 and C49 formed a dual unit, and the link between heater and cathode of V6 was omitted in some versions.

In later models, however, a number of modifications were introduced which are not included in the A272. They were added to improve performance, and if necessary they may be added to models in which they are not present if the following difficulties are encountered.

Parasitic Oscillation on Gram.—To prevent the

possibility of parasitic oscillation when the receiver was switched to Gram, a 47Ω stopper was inserted in the lead to V2b control grid and the co-axial lead was removed. As this modification tended to alter the F.M. I.F. bandwidth slightly, the 47Ω resistor was removed and the co-axial lead restored when a modified waveband switch was fitted to later models.

In addition, S6 and S17 which were not present in the original version, were added, and an 18MΩ resistor was connected between chassis and V2b control grid. S6 was added to remove

harmonic of the F.M. I.F., the chassis connection of C44 (F4) is made to a chassis tag near the discriminator transformer L21, L22, instead of to the chassis point on its base.

GENERAL NOTES

Switches.—S1-S20 are the waveband and A.M./F.M. changeover switches, ganged in two rotary units beneath the chassis. The units are indicated in our underside view of the chassis, where they are identified by the numbers 1 and 2 in diamond surrounds, and shown in detail in col. 4, where they are drawn as seen when viewed in the direction of the arrows in the under-chassis illustration.

The associated table in column 5 shows the switch positions for the four control settings, starting from the fully anti-clockwise position of the control knob. A dash indicates open and C closed.

Drive Cord Replacement.—About 38in of braided line is required for a new drive cord. It should be run as indicated in the sketch of the tuning drive system shown in cols. 1, 2, where it is drawn as seen when viewed from the front of the chassis with the tuning gang at maximum capacitance.

Scale Lamps.—These are two 6.5V, 0.3A lamps with clear spherical bulbs and M.E.S. bases.

VALVE ANALYSIS

Valve voltages given in the table below are those derived from the manufacturers' information. They were measured with a 20,000Ω/V meter, chassis being the negative connection in every case. The receiver was operating from A.C. mains of 240V with the mains adjustment set at the 240-250V tapping. There was no signal input.

Valve Table

Valve	Anode (V)	Screen (V)	Cath. (V)
V1a ECC85 ..	114	—	—
V1b ECC85 ..	109	—	—
	24	—	—
V2a 6C9 ..	172	—	—
	30	—	1.1
V2b 6C9 ..	—	—	1.3
	200	73	1.1
V3 6F18 ..	174	78	1.3
	178	82	1.3
V4d EABC80	166	76	1.1
	72	—	—
	71	—	—
V5 6P1 ..	248	210	7.8
	242	200	7.3
V6 UU9 ..	245 ¹	—	265.0
	245 ¹	—	260.0

*Measured with receiver switched to M.W.
 †Measured with receiver switched to F.M.
¹A.C. reading.

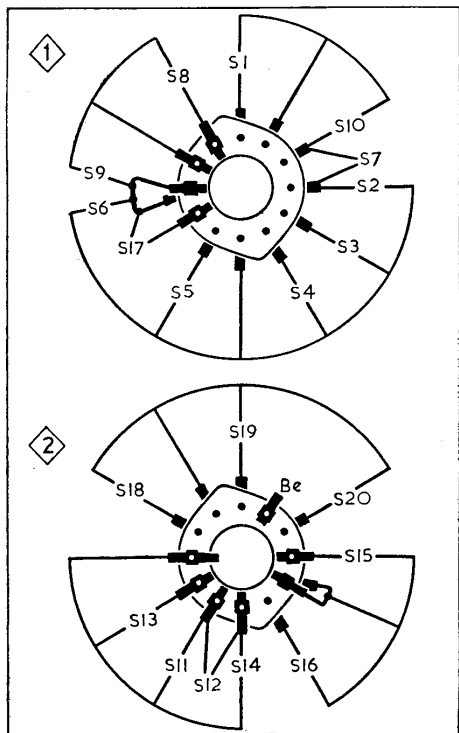

Diagram of the switch unit drawn as seen from the rear of an inverted chassis as indicated in location G3 of the picture at the top of this page.

Switch Table

Switches	FM	MW	LW	Gram
1	C	—	—	—
2	C	—	—	—
3	—	—	—	—
4	—	C	—	—
5	—	—	C	—
6	—	C	C	C
7	—	—	—	C
8	—	C	—	C
9	—	—	—	C
10	C	C	C	C
11	—	—	C	C
12	—	—	—	C
13	—	C	—	C
14	—	—	—	C
15	C	C	—	C
16	—	C	C	C
17	—	—	C	C
18	—	C	—	C
19	C	—	C	C
20	—	—	—	C

a slight hiss on Gram at high volume control settings, while S17 was added to prevent the possibility of parasitic oscillation on Gram. (See also "A.M. interference on F.M." below.)

L.W. Instability.—C60 was originally 560pF and was transposed with R27, C60 being connected to V5 anode. These changes were made to prevent the possibility of instability on the L.W. band.

Modulation Hum.—C63 and C64 were added to prevent the possibility of modulation hum on F.M.

I.F. Feedback.—In early receivers, C9 and C16 were omitted. They were introduced to prevent the possibility of I.F. feedback.

A.M. Interference on F.M.—A 330pF capacitor and a 220kΩ resistor were connected in series between the junction of R20, C52 and the junction of R18, C49. These components were removed on later receivers to reduce the breakthrough of A.M. interference (ignition, etc.) from a strong nearby source during the reception of an F.M. transmission. In receivers not fitted with the modified waveband switch described previously, the removal of these components also results in the removal of hiss on Gram at high volume control settings.

F.M. Interference on Channel III.—In later receivers, to reduce the radiation of the 5th