

"TRADER" SERVICE SHEET
1375

MURPHY U198H & U198M

2-band Table Receivers for A.C. or D.C. Mains Operation

U198H, April 1954, £10 1s 5d; U198M, March 1954, £10 1s 5d. Purchase tax extra.

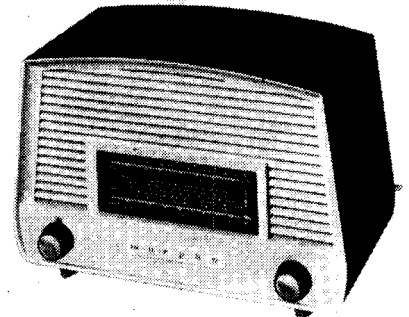

THE Murphy U198H is a 2-band superhet receiver housed in a maroon plastics moulded cabinet and employing five valves and a ferrite rod aerial. It is designed to operate from A.C. or D.C. mains of 200-250V, 25-100c/s in the case of A.C. Average mains consumption is 41W.

Model U198M employs an identical chassis, but is housed in a two-tone maroon and cream cabinet.

Release dates and original prices:

CIRCUIT DESCRIPTION

Tuned ferrite rod aerial input **L1, C1, C3** (M.W.) and by **L2, C2** and **C3** (L.W.) precede triode-hexode frequency changer **V1**.

Parallel-fed local oscillator **V1a** is tuned by **L6, C12** and **C16** (M.W.) and by **L7, C11, C13, C14** and **C16** (L.W.). Series damping by **R3** on M.W.

Intermediate frequency 470 kc/s.

Variable- μ R.F. pentode **V2** operates as intermediate frequency amplifier with tuned

Appearance of the U198M. This has a two-tone cabinet; the U198H is similar but has a single-tone cabinet.

transformer couplings **C6, L3, L4, C7; C17, L8, L9, C18**.

Diode signal detector is part of a double-diode-triode valve **V3**. Audio frequency component in its rectified output is developed across **R9** and volume control **R8**, and passed via **C20** to the control grid of **V3** triode section, which operates as A.F. amplifier. I.F. filtering by **C19**. The D.C. potential developed across **R8, R9** is fed back as bias via decoupling circuit **R7, C8** to **V1** and **V2**, giving automatic gain control.

Resistance-capacitance coupling by **R10, C24** to the control grid of pentode output valve **V4**. Tone correction is by frequency selective negative feedback derived from the un-bypassed cathode bias resistor **R16**, and fed via **R12, C21** to the coupling network formed by volume control **R8** and **R9**. High and middle frequencies are progressively at-

(Continued col. 1 overleaf)

Resistors			Capacitors		
R1	1M Ω	F4	C1	35pF	F3
R2	47k Ω	F4	C2	110pF	F4
R3	10 Ω	G4	C3	528pF	C2
R4	27k Ω	F4	C4	470pF	G4
R5	27k Ω	F4	C5	0.04 μ F	G4
R6	68k Ω	F4	C6	100pF	B1
R7	1.5M Ω	F4	C7	100pF	B1
R8	500k Ω	D3	C8	0.04 μ F	F4
R9	1.5k Ω	D3	C9	68pF	C1
R10	220k Ω	E4	C10	520pF	G4
R11	10M Ω	F4	C11	390pF	C2
R12	10k Ω	D4	C12	35pF	C1
R13	470k Ω	E4	C13	145pF	G3
R14	100k Ω	E4	C14	35pF	C2
R15	1.5k Ω	B2	C15	100pF	G4
R16	220 Ω	D4	C16	528pF	C2
R17	934 Ω	A1	C17	100pF	B1
R18	160 Ω	A1	C18	390pF	E4
R19	168 Ω	A1	C19	270pF	E4
			C20	0.01 μ F	A2
			C21	0.02 μ F	D3
			C22	0.001 μ F	E4
			C23	0.01 μ F	E4
			C24	0.005 μ F	D4
			C25	32 μ F	B2
			C26	0.01 μ F	B2
			C27	32 μ F	B2

Coils*		
L1	—	G3
L2	10.0	E3
L3	14.5	B1
L4	14.5	B1
L5	—	C1
L6	5.2	C1
L7	9.8	C1
L8	14.5	B1
L9	5.5	B1
L10	2.5	A2

Other Components*		
T1	{ a 6.3 } B2	
	{ b 185.0 }	
	{ c — }	
F1	250mA	E4
S1-S8	—	G4
S9	—	E4
S10, S11	—	D3

*Approximate D.C. resistance in ohms.

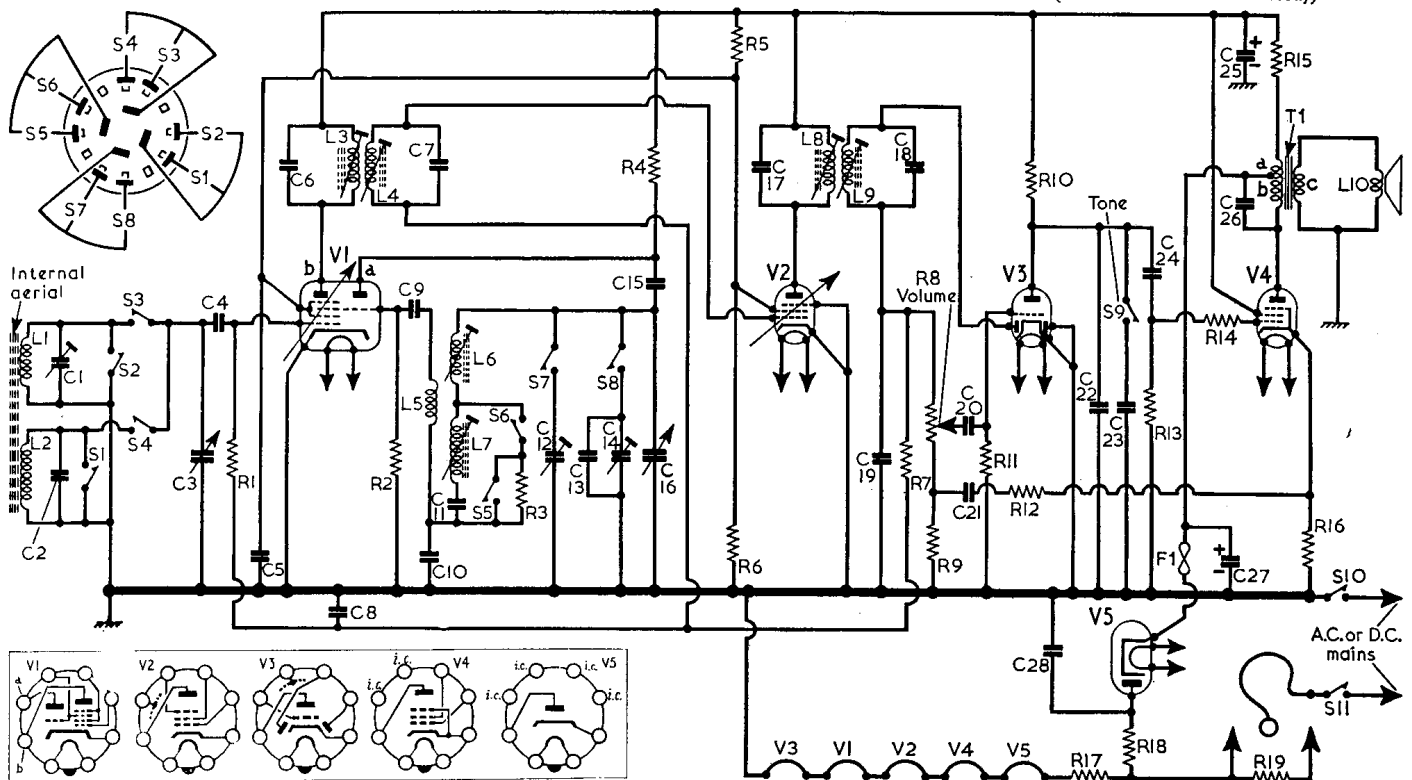

Circuit diagram, valve base connections and switch diagram of the U198H.

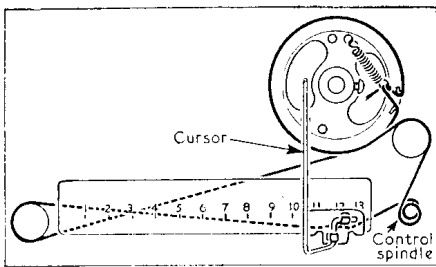

Above.—Sketch of the tuning drive system as seen from the front of an upright chassis.

Circuit Description—continued

tenuated as the volume control settings are reduced, thus compensating for loss of low frequencies at low volume control settings. Tone control by C23 via 2-position switch S9.

H.T. current is supplied by half-wave rectifying valve V5. Smoothing by C27, R15 and C25. Hum neutralizing is achieved by passing H.T. current through winding of output transformer T1.

CIRCUIT ALIGNMENT

Equipment Required.—An accurately calibrated signal generator; an A.C. voltmeter for use as output meter; a coupling coil for use during R.F. alignment and consisting of 20 turns of wire wound on a 6in diameter former; a non-metallic trimming tool.

As it is necessary to remove the chassis from the cabinet for alignment purposes, an alignment calibration scale is provided, and is situated below the tuning scale backing plate.

I.F. Stages

- 1.—Switch the receiver to M.W. and turn the volume control to maximum. Connect output meter across T1 secondary winding. Connect signal generator via a 0.01 μ F capacitor to V2 control grid (pin 6) and chassis. Tune the receiver to the 10.00 calibration mark on the alignment scale.
- 2.—Detune L9 (B1) by unscrewing its core several turns. Feed in a 470kc/s signal and adjust L8 (E4) and then L9 (B1) for maximum output. Do not readjust L8.
- 3.—Connect signal generator across C1 (F3). Unscrew L4 (B1) several turns. Feed in a 470kc/s signal and adjust L3 (F4) and then L4 (B1) for maximum output. Do not readjust L3.

R.F. and Oscillator Stages

- 4.—When the chassis is in the cabinet, check that with the gang at maximum the cursor coincides with the right-hand ends of the tuning scales. Connect the R.F. coupling coil to the signal generator output and place it about 1ft away from the R.F. end of the receiver, with its axis in line with the ferrite aerial rod.
- 5.—Switch the receiver to M.W. and tune it to 8.15 on the calibration scale. Feed in a 609kc/s signal and adjust L6 (C1) for maximum output.
- 6.—Tune the receiver to 1.85 on the calibration scale. Feed in a 1,364kc/s signal and adjust C12 (C1) and C1 (F3) for maximum output.
- 7.—Repeat operations 5 and 6.
- 8.—Switch the receiver to L.W. and tune it to 7.35 on the calibration scale. Feed in a 176.5kc/s signal and adjust L7 (C2) for maximum output.
- 9.—Tune the receiver to 1.05 on calibration scale. Feed in a 300kc/s signal and adjust C14 (C2) for maximum output.
- 10.—Repeat operations 8 and 9.

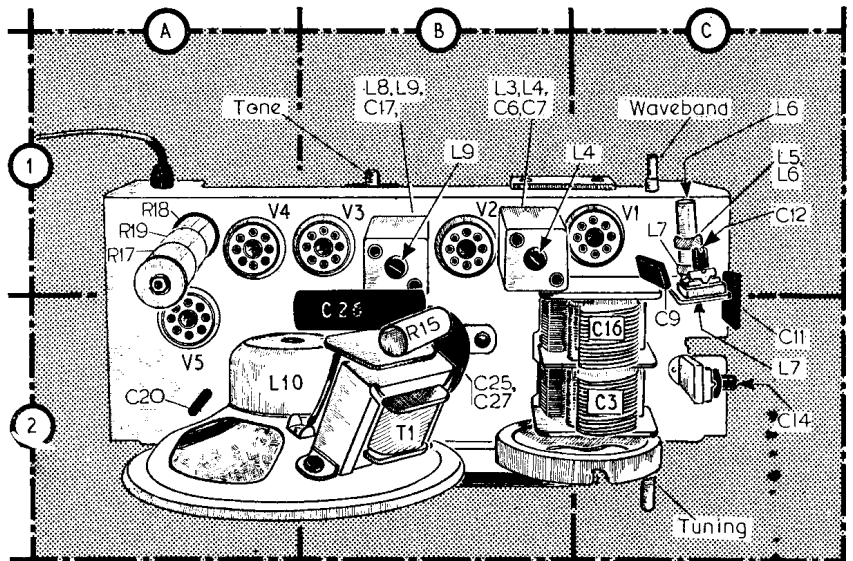

Above.—Plan view of the chassis.

GENERAL NOTES

Switches.—S1-S8 are the waveband switches ganged in a single rotary unit beneath the chassis in location reference G4. The switch contacts are identified in the diagram shown in the top left-hand corner of the circuit diagram overleaf, where they are drawn as seen when viewed in the direction of the arrow in the under-chassis illustration. S1, S3, S6 and S7 close on M.W., while S2, S4, S5 and S8 close on L.W.

Drive Cord Replacement.—About 31in of nylon-braided glass yarn is required for a new drive cord, which should be run as shown in the sketch of the tuning drive system in col. 1, where it is drawn as viewed from the front of the chassis with the gang at maximum.

Modifications.—S9 and C23 may be omitted in early versions of this receiver. V2 may be a UF41, and V3 a UBC41. C18 may be situated inside L8, L9 I.F. transformer can. C28 was 0.02 μ F but was increased to 0.05 μ F to avoid modulation hum.

In Model U198M, C28 is fitted in L8, L9 I.F. transformer can. In later versions L1 is spread instead of wave wound, and is connected in series with L2 for L.W. opera-

tion. The D.C. resistance of L2 is then 9.5 Ω . C1 and C2 are then connected via a wavechange switch across C3. C23 was changed to 0.005 μ F and S9 was changed to a double-throw switch. C23 was then connected directly to V3 anode. S9 connected C23 or C21 to the junction of R8 and R9, modifying the negative feed-back circuit.

T1 may be modified in both models, in which case the D.C. resistance is: a, 6.3 Ω ; b, 200 Ω .

VALVE ANALYSIS

Valve voltages given in the table below are those derived from the manufacturers' information. Voltages were measured on a 20,000 Ω /V meter, chassis being the negative connection in every case. The receiver was switched to M.W., but there was no signal input.

Valve		Anode (V)	Screen (V)	Cath. (V)
V1 UCH42	{mixer	161	49	—
	{osc.	75	—	—
V2 10F9	..	161	49	—
V3 10LD3	..	71	—	—
V4 UL41	..	183	161	9.5
V5 UY41	..	—	—	196.0

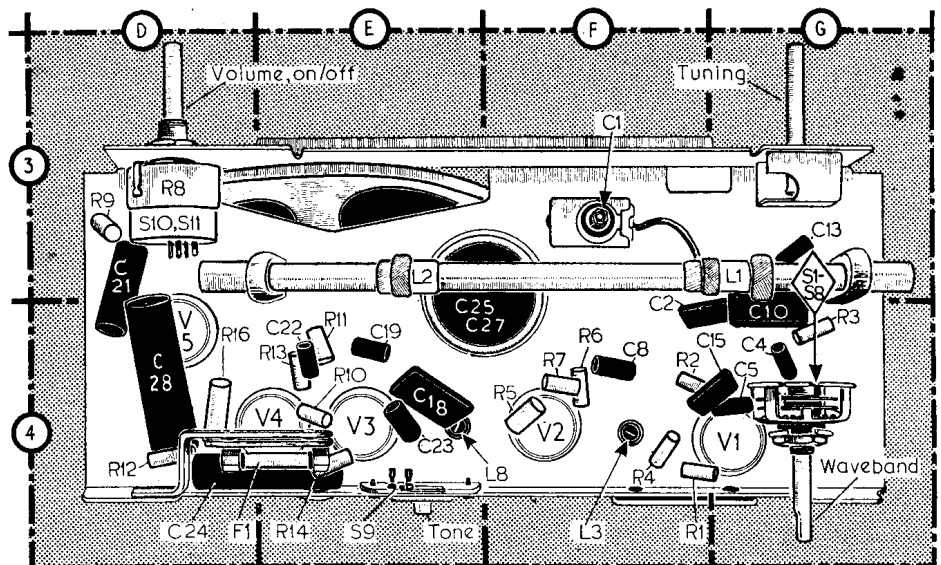

Underside view of the chassis. S9, C23 may be omitted in early versions.