



D Y N A T R O N

RECORD REPRODUCER SERVICE MANUAL

MODEL HFC10 'MAZURKA'

October 1969

'MAZURKA' MODEL HFC10

General Description

The 'Mazurka' Model HFC10 is a fully transistorised stereo record reproducing instrument containing a Dynatron Transpower stereo amplifier and a Garrard Model SP25 Mk. 2 player unit fitted with Goldring G800 Magnetic Stereo Cartridge. The amplifier has an output exceeding 12 watts each channel and a comprehensive tone control network in each pre-amplifier channel. There is provision for connecting a self-powered tuner unit and either mono or stereo tape recorders may be used in conjunction with the instrument. Standard DIN pattern sockets are provided for these inputs and also for loudspeaker connection. Dynatron loudspeaker units are recommended for this instrument—either LS100, LS150, LS200 or LS300 are suitable depending on customer choice. Other loudspeakers may be used of 4 ohm impedance for full power use although higher impedance may be considered at reduced power. The instrument may be adjusted for AC mains supplies of 110 volts, 190–220 volts and 225–250 volts and 50 or 60 c/s (Hz).

Technical Data

Mains Voltage Range:

110 volts, 190–220, 225–250. Adjusted at mains transformer. (Despatched from factory for Home Sales set to 225–250 volts 50 c/s (Hz).)

Mains Supply Frequency:

50 or 60 c/s (Hz) adjusted by pulley change on motor. (Steel pulley for 50 Hz, Brass pulley for 60 c/s.)

Controls:

Mains On-Off, Bass Boost (Loudness network).
Input selector switch, Volume, Balance, Bass and Treble.

Indicator Lamp:

Long life neon lamp.

Fuses:

Three at 1 amp.

Record Player Unit:

Garrard SP25 Mk. 2.

Cartridge:

Goldring G800 stereo. Diamond stylus. Tracking force 3 gms. maximum.
FOR MICROGROOVE RECORDS ONLY. NOT 78 R.P.M.

AMPLIFIER SPECIFICATION:

16 Transistors (10 Ge types, 6 Si types).
4 Diodes. 1 Se power bridge.

Maximum Power Output:

12.5 watts R.M.S. per channel into 3 ohms.
(15 watts per channel IHFM rating.)

Distortion:

Less than 1% T.H.D. at maximum output 1KHz.
0.4% T.H.D. at 8 watts output 1KHz.

Hum and Noise:

Main amplifier — 95dB relative 10 watts.
Tape input — 7. dB relative 10 watts.
P.U. Magnetic — 62dB relative 10 watts.

Frequency Response:

Radio and tape inputs 3dB points 30Hz to 20 KHz tone controls flat.
P.U. input corrected to R.I.A.A. curve ± 1.5 dB 40 Hz to 20 KHz.

Input Sensitivities:

Radio and tape inputs 36 mV for 10 watts at 1 KHz into 20 K ohms.
P.U. Magnetic 5 mVolts for 10 watts at 1 KHz.

Signal Handling:

+ 30 dB on specified input sensitivities.

Bass Boost Switch:

+ 10 dB at 100 Hz. Volume control at -30 dB relative to maximum.

Tone Controls:

Bass ± 10 dB at 100 Hz relative 1 KHz.
Treble ± 10 dB at 10 KHz relative 1 KHz.

Balance Control:

+ 6 dB — 2 dB each channel.

Tape Socket:

Output greater than 35 mV into 20 Kohms or higher.
(Unaffected by volume or tone control settings.)

N.B.:

If 78 r.p.m. records are to be used it is recommended that a replacement head shell be obtained and a turnover cartridge such as the Sonotone 9TAHC fitted. For correct matching 100 Kohms should be inserted in series with each channel within the head shell. The pick-up arm should be balanced and the tracking force set to 5 gms. when using this cartridge.

Dimensions

19 in. wide, 7½ in. high, 16¼ in. deep.
(48 × 19 × 41 cms.)

Weight

24½ lbs. (11 Kg.).

Cabinet

Teak veneer and solid, tinted plastics lid cover.

Chassis Removal

Much service work can be undertaken without removing chassis from cabinet by merely releasing motor board mounting screws and lifting motor board. Should complete removal be required then proceed as follows:

1. Remove pickup and motor supply plugs from chassis.
2. Remove rotary control knobs by pulling off.
3. Release 4 BA nuts securing power/sockets panel to rear wall of cabinet.
4. Release 4 BA nuts from chassis mounting brackets and withdraw complete unit from cabinet.

N.B. — (It is not necessary to remove stand ST16 if fitted to cabinet).

Static Voltages

These voltages are shown on circuit diagram.

Circuit Diagram

This diagram shows common power supply and left-hand stereo channel, the right-hand channel being identical. Alternative mains transformer connections are shown also input and output sockets.

Transistor Functions and Types

VT 1 — 101	BC 109 or BC 173	Pre-amp gram.
VT 2 — 102	BC 108 or BC 172	Tone control amp.
VT 3 — 103	BC 108 or BC 172	A.F. amp.
VT 4 — 104	NKT 213	Driver.
VT 5 — 105	NKT 717	Phase Splitter Drivers.
VT 6 — 106	NKT 212	
VT 7 — 107	NKT 452	Output.
VT 8 — 108	NKT 452	
D1 — D101	NKT 279A	Bias compensation.
D2 — D102	NKT 279	

To operate on other Mains Supplies

1. Change tappings on mains transformer.
2. Change record player motor tappings.
3. Change motor drive-pulley for 60 c/s or 50 c/s.
4. Change mains fuse as necessary.

1. Transformer Wiring:

For 110 V Supply

Link 1 with 3
Link 2 with 4
Red Wire to 1
Black Wire to 2

For 240 V Supply

Link 2 with 3
Red Wire to 1
Black Wire to 5

For 220 V Supply

Link 2 with 3
Red Wire to 1
Black Wire to 4

2. Record Player Motor:

Connect links on voltage tapping plate as shown on motor terminal block cover.

3. Drive Pulley:

Remove turntable and fit correct drive pulley.
Steel Pulley for 50 c/s.
Brass Pulley for 60 c/s.

4. Mains Fuse:

Locate and change mains fuse if necessary.
Use 1 amp rating for 220 and 240 V supply.
Use 2 amp rating for 110 V supply.

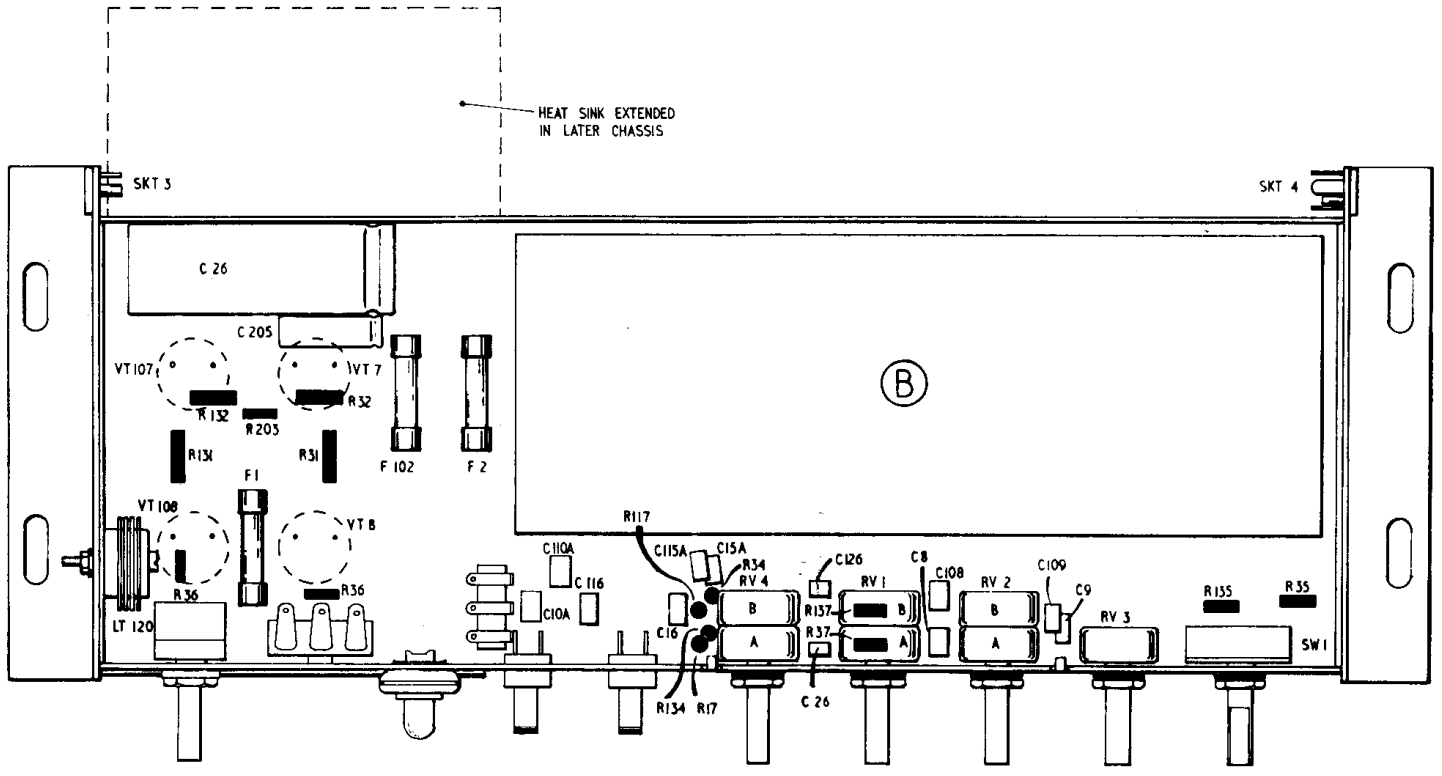

NOTE: ALL RESISTORS SHOWN SOLID BLACK.

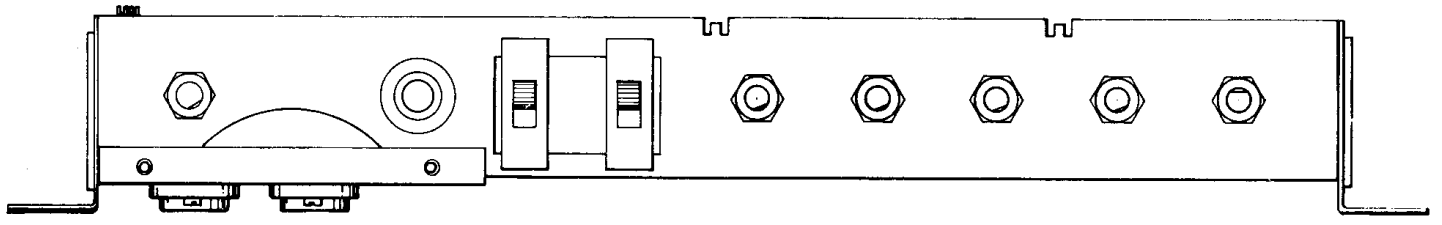

CHASSIS LAYOUT

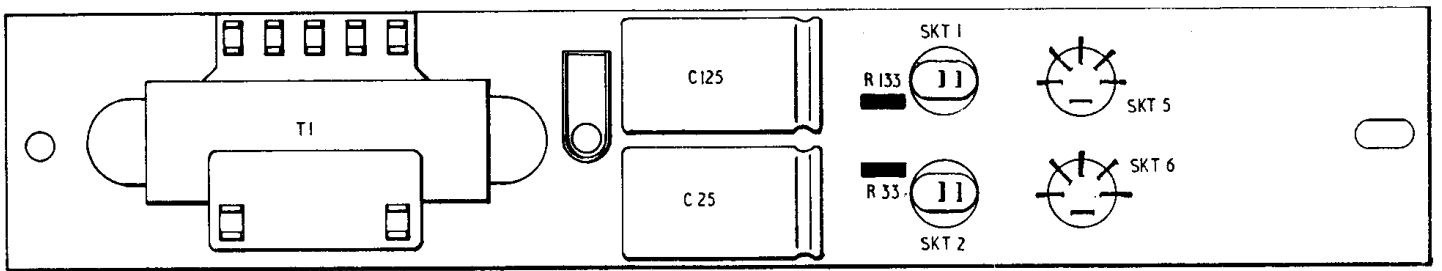

POWER & SOCKETS PANEL LAYOUT

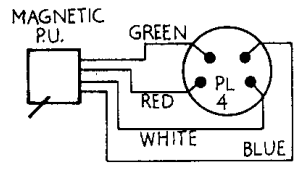
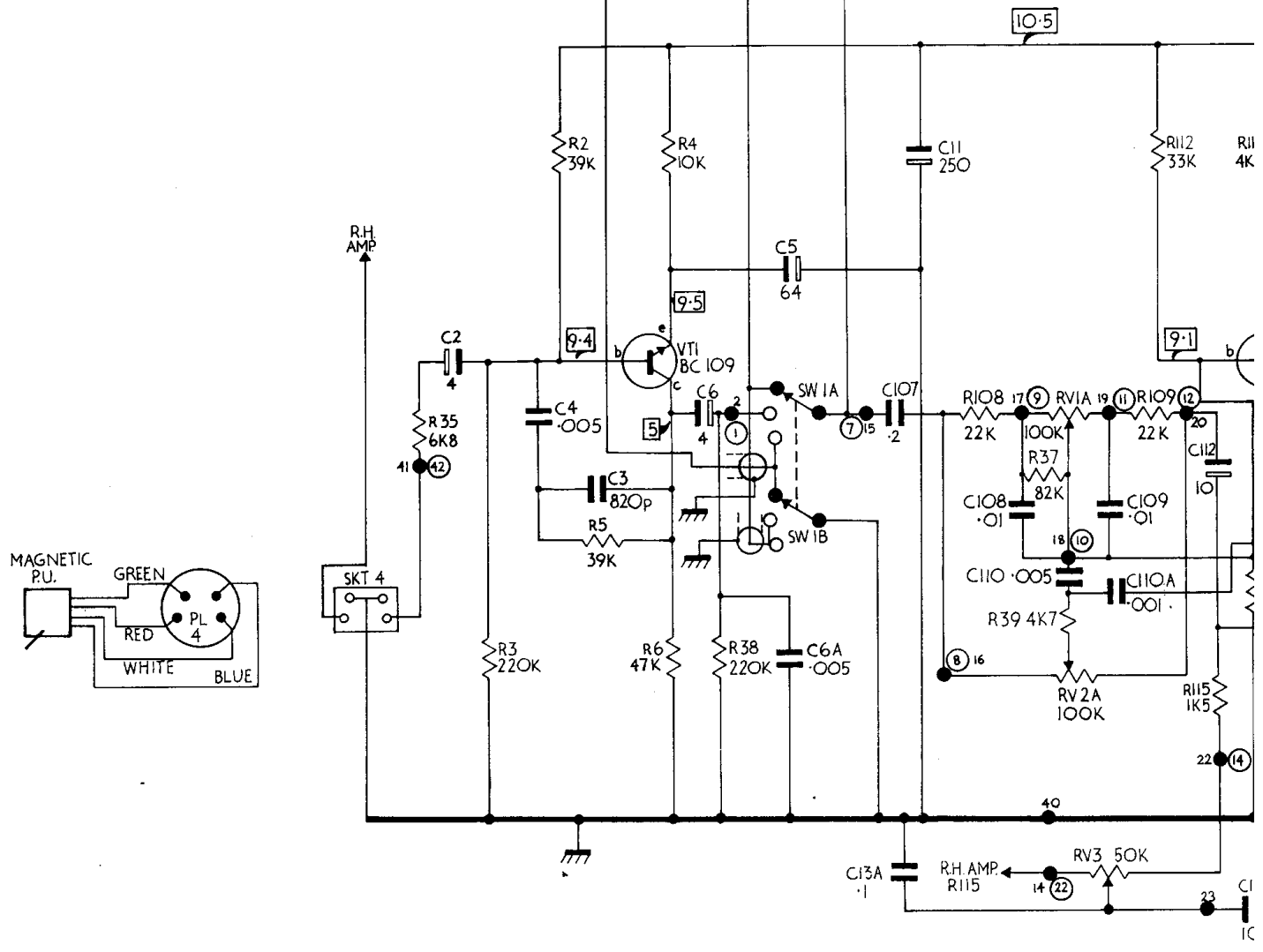
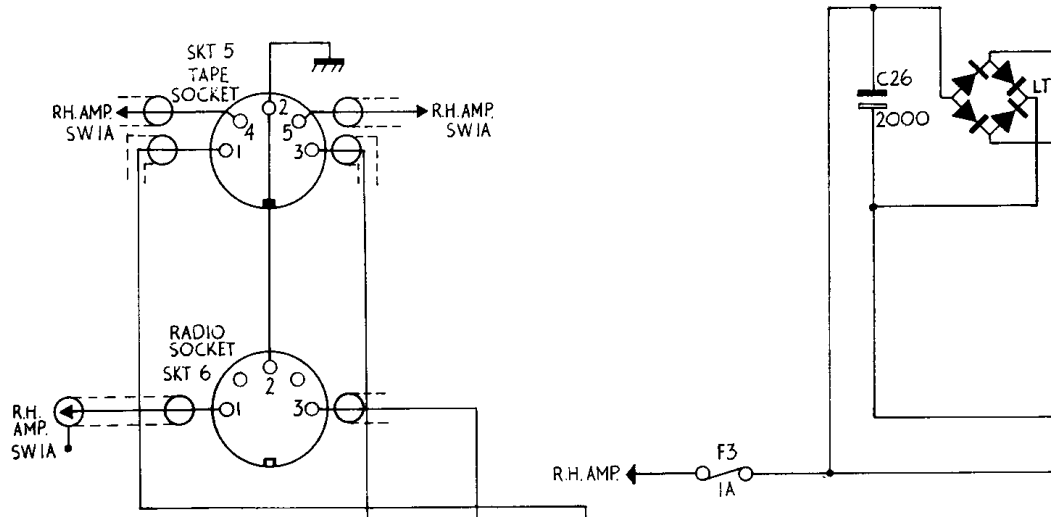

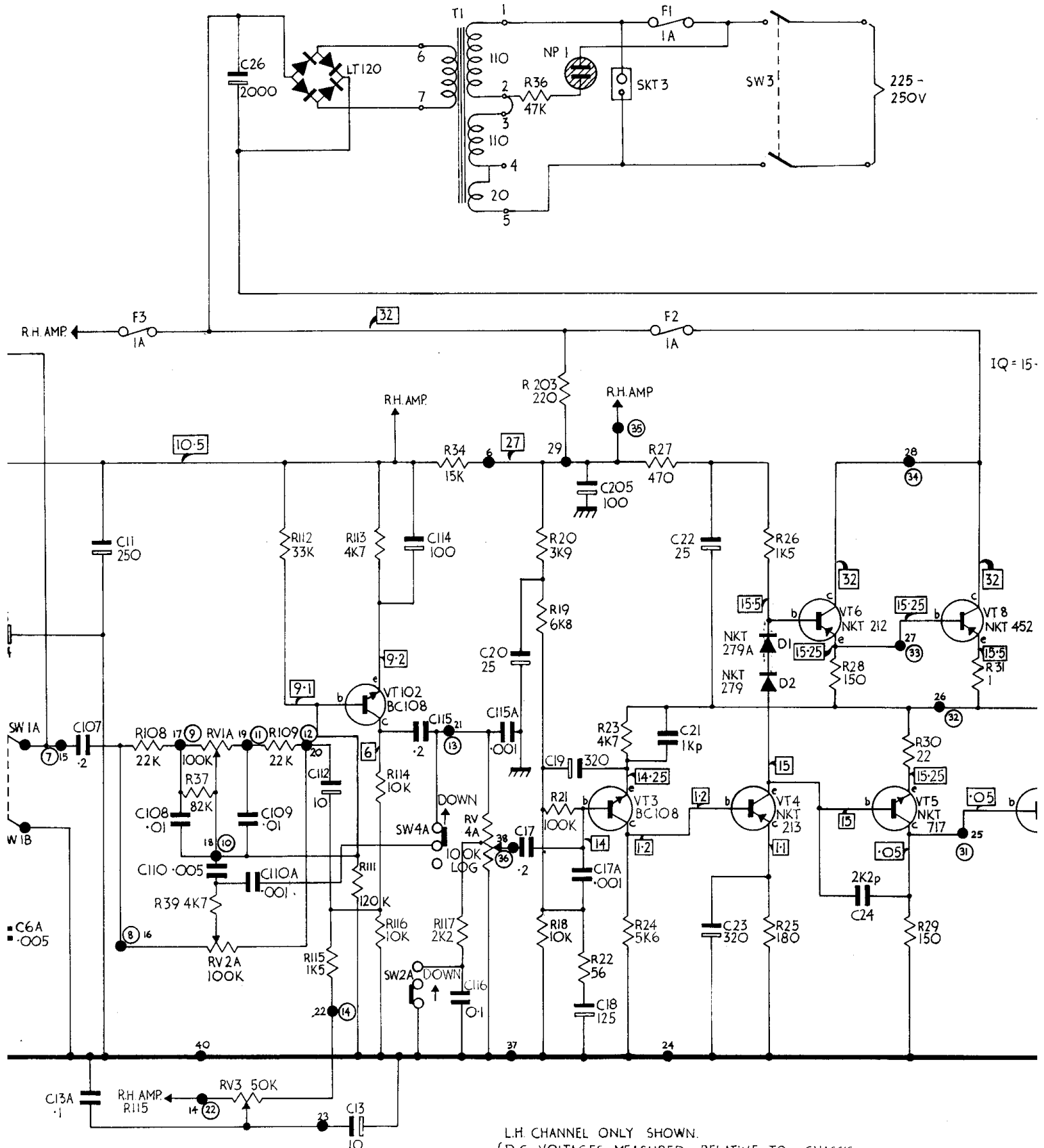
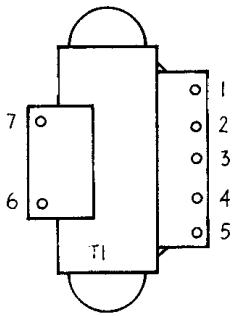

L.H. CHANNEL ONLY SHOWN.
 { D.C. VOLTAGES MEASURED RELATIVE TO CHASSIS
 { USE AVO 8 - NO SIGNAL CONDITIONS: 240V INPUT
 23 ● BOARD CONNECTOR PINS
 ⑭ ○ R.H.AMP. PIN NUMBERS

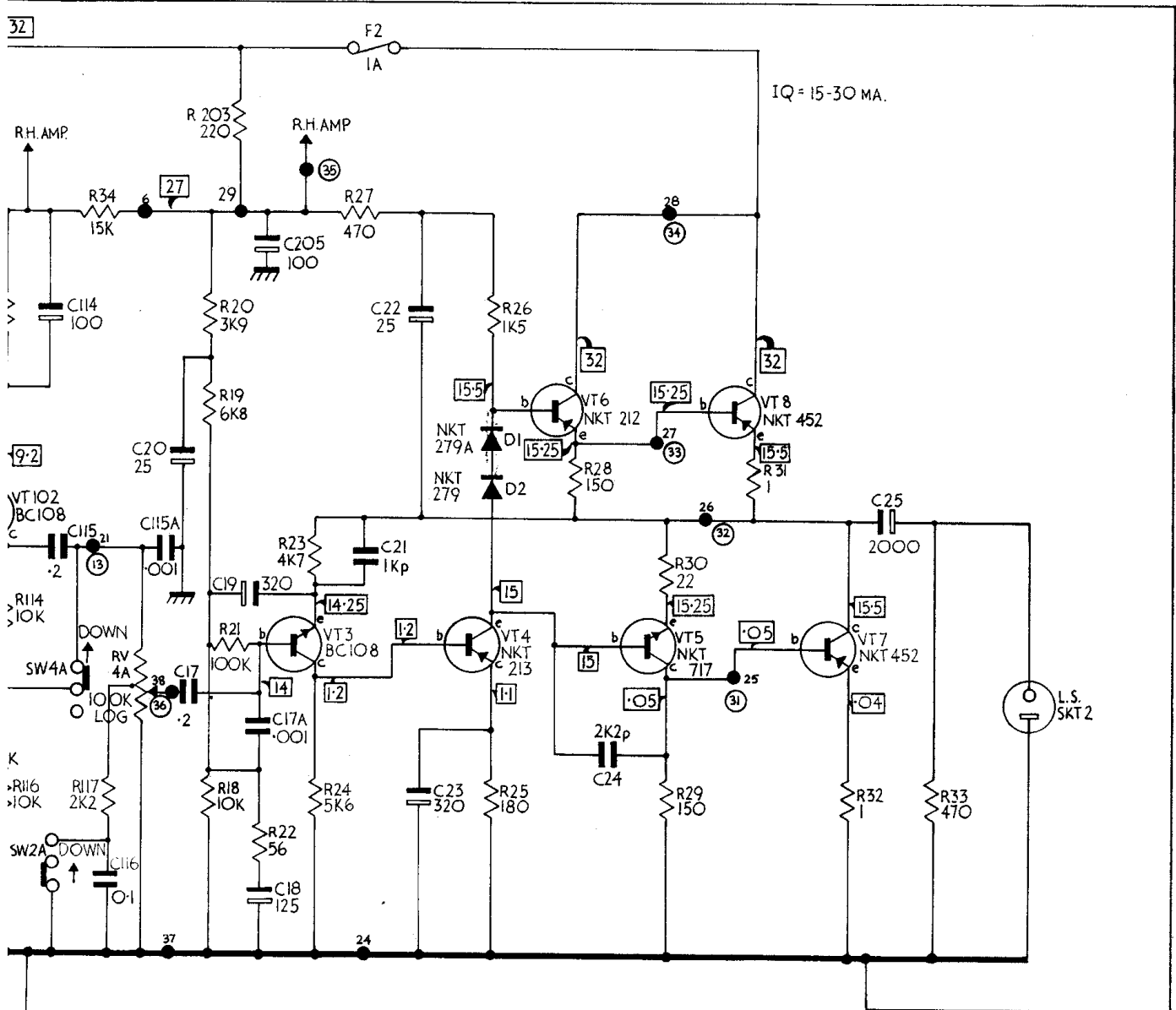
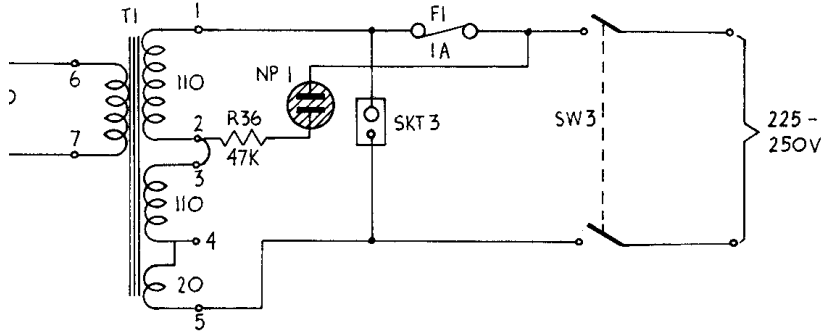
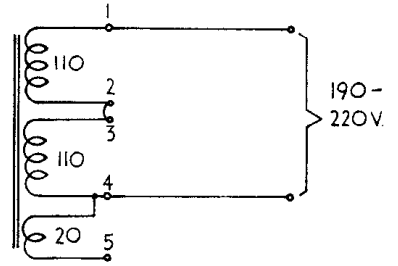
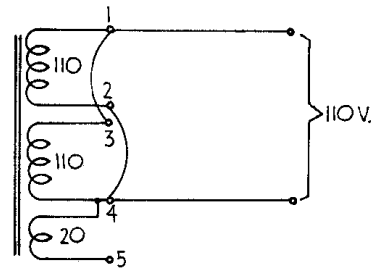
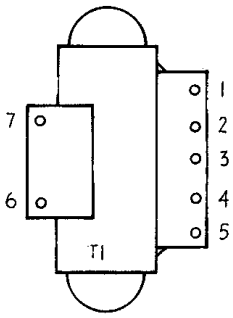

L.H. CHANNEL ONLY SHOWN.

{ D.C. VOLTAGES MEASURED RELATIVE TO CHASSIS
USE AVO 8 - NO SIGNAL CONDITIONS: 240V INPUT

23 ● BOARD CONNECTOR PINS

14 ○ R.H. AMP. PIN NUMBERS

IQ = 15-30 MA.