



GRAMOPHONE

PICK UP

*type 19*

incorporated in

models 274

and 280

*also complete spare  
part lists for pick-ups  
from 1932 onwards*

# *Marconiphone Service Manual*

PRIVATE AND CONFIDENTIAL

TO THE TRADE ONLY



---

---

## MODEL 19 IS THE IDEAL PICK-UP FOR THE MODERN SET

---

---

### ELECTRICAL DATA.

D.C. Resistance of Armature Coil ... ..	900 ohms	} 1,350 ohms total.
D.C. Resistance of Hum Neutralising Coil ... ..	450 ohms	
A.C. Impedance ... ..	Apprx. 4,200 ohms at 800 cycles.	
Output ... ..	0.75 volts R.M.S.	

### DISMANTLING.

To gain access to the pick-up movement, remove the beeswax covering the 2 screws in centre (under-side) of pick-up head and remove the screws.

The 4 screws fixing the polepieces of pick-up, which are also covered with wax, must not be disturbed. These pole fixing screws are situated at either side of, and in line with, the needle hole (Fig. 2).

### ADJUSTING THE ARMATURE (Fig. 1).

The armature, which should be midway between the two poles of magnet, may be adjusted by moving the clamp which holds the rubber damping pad. See that the slit in the rubber pad is locating the end of armature.

When properly fitted the flat end of armature will be just visible through slit in rubber.

Carefully remove any dust or iron filings which may have collected around the movement, as these will give rise to buzz or rattle when pick-up is in operation. Particular attention must be paid to the needle end of armature, which, due to exposure, is liable to collect iron dust or filings.

A small piece of 'plasticine' will be found useful for picking up filings from awkward corners.

**DO NOT REMOVE MAGNET UNLESS THIS IS ABSOLUTELY NECESSARY, AND DO NOT KNOCK THE PICK-UP HEAD.**

### THE MAGNET.

Do not remove the magnet until a "keeper" has been placed across the end faces.

Use a FLAT piece of iron or steel which effectively covers both ends of magnet, and wrap carefully so that iron filings will not be collected. The ground (smooth) face of magnet must be in contact with the poles.

### RENEWAL OF COILS.

Care must be exercised in connecting the hum and armature coils, which must be in "series."

Connect the two inner ends of coils together, and connect the two remaining (outer) wires to the rubber-covered output leads (see Fig. 2).

Before finally fixing the position of armature coil with beeswax, the coil must be carefully adjusted so that inner lead is in the centre of gap in armature. Also see that the coil former is not fouling the armature.

The hum coil must be located in the recess in moulding and firmly held in position by beeswax.

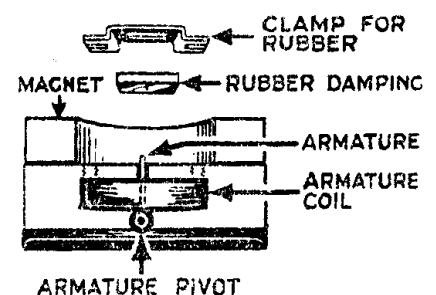

Fig. 1.

---

---

**MODEL 19 IS PARTICULARLY SUITABLE FOR MAINS RECEIVERS**

---

---

## THE BAKELITE ARM GIVES COMPLETE PROTECTION ON D.C. SUPPLIES

### RE-ASSEMBLING THE PICK-UP.

Adjust the position of coil connections so that they will not be broken when the two fixing screws are inserted. Cover the fixing screw heads with wax.

The spring which holds the arm erect for needle changing is held at one end by the pivot screw, and at the other end by a pin which must locate in the slot of the pick-up base.

When re-assembling the pick-up arm, slip one end of spring on to pivot screw before tightening the screw. To enable pin to be inserted through loop, bend a stiff hook so that spring can be stretched.

The stop pin (Fig. 2) serves to limit the swing of the pick-up arm, and also to prevent the ball bearings becoming displaced in the event of the arm being pushed beyond its normal needle changing position. See that the cord slot in base is in the position shown in Fig. 2 (in regard to the arm) before tightening the stop screw—THIS IS VERY IMPORTANT.

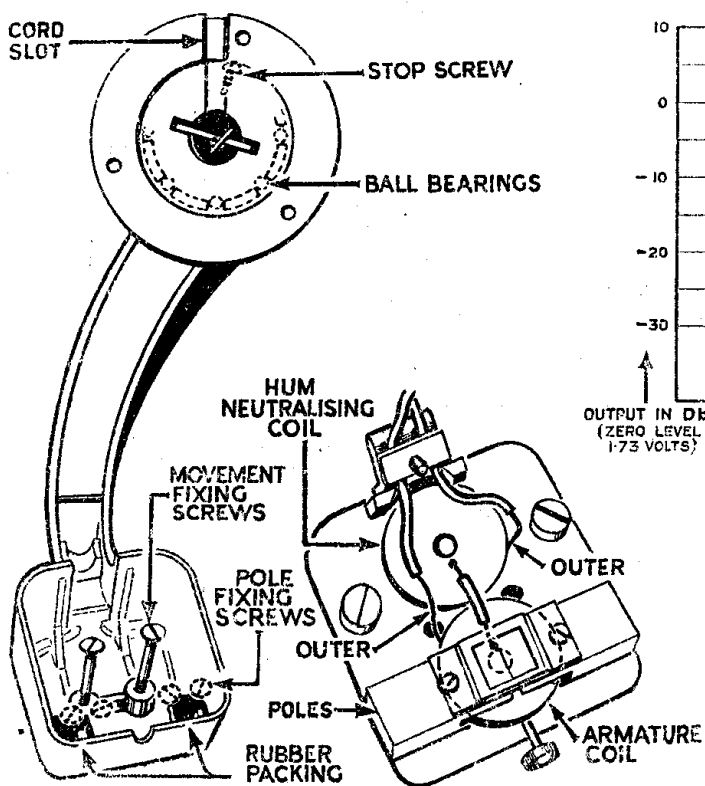

Fig. 2.

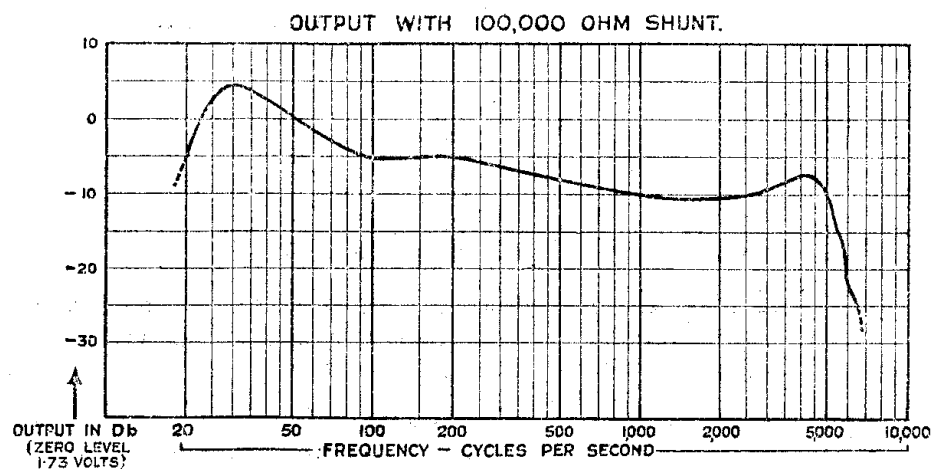

Fig. 3.

### ADJUSTMENT OF OUTPUT.

The resistance of the volume control for use with this pick-up will vary according to the characteristics of the amplifier.

In most cases a 50,000-ohm volume control will be found satisfactory; but where the receiver or amplifier tends to emphasize the treble register, a volume control of lower resistance should be used.

In exceptional circumstances the volume control, which should preferably be logarithmically graded, may require to be as low as 1,000 ohms.

Where the amplifier is fitted with a "Gram." volume control, a *shunt* resistance connected as shown in Figs. 4, 5 and 6 may be found necessary. The resistance value will depend on the type of instrument.

To prevent overloading of the amplifier ("blasting") a non-inductive resistance between 2,000 and 10,000 ohms may be required. Connecting the resistance *in series* as shown in Figs. 4, 5 and 6 will reduce the voltage applied to grid of valve.

The presence of overloading at the grid of the input valve may be detected by a D.C. milliammeter inserted in the anode circuit. The needle should remain practically steady when volume control is fully advanced.

Check the bias of pick-up input valve before adding *series* resistance.

THE HUM-NEUTRALISED WINDING ELIMINATES INDUCTION FROM A.C. MOTORS

**CIRCUIT ARRANGEMENTS.**

The adaptation of the pick-up to a radio instrument must be carried out according to its circuit: three normal cases are shown diagrammatically in Figs. 4, 5 and 6.

**BATTERY-OPERATED RECEIVERS (Fig. 4).**

If only one L.F. stage is employed connect the pick-up to the grid of the detector valve and adjust the bias so that the valve is operating as an L.F. amplifier.

Unless a switch is fitted as shown in Fig. 4 the pick-up lead connected to the grid terminal of the instrument must be removed before satisfactory 'radio' can be obtained.

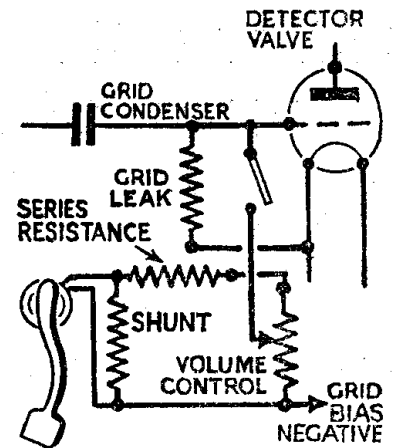

Fig. 4.

**A.C. MAINS-OPERATED RECEIVERS (Fig. 5).**

The lead from the pick-up to the input sockets must be kept as short as possible, and the black rubber lead which is attached to the metal braid covering must be connected to earth.

If the lead is cut in order to insert a volume control, the two parts of the sheathing must be connected together so that the screening is electrically continuous between pick-up and the grid socket of the input valve.

When an electric turntable motor is used the frame of the motor must be earthed.

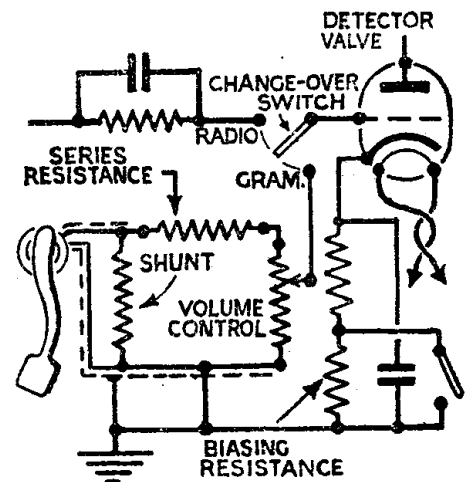

Fig. 5.

**D.C. MAINS OPERATED RECEIVERS (Fig. 6).**

When the pick-up is used with an instrument operating on D.C. mains, make sure that both pick-up sockets are isolated from the mains circuit of the instrument by condensers. This will minimise the risk of the windings of pick-up becoming "live."

Model 19 is particularly suitable for instruments operating from D.C. Mains, since its frame or arm is of high grade insulating material.

Carefully follow the makers' instructions relating to D.C. operated receivers or amplifiers before connecting the pick-up "earth." Wrongly connecting the pick-up screening may cause hum.

When an electric motor is employed earth the frame of motor.

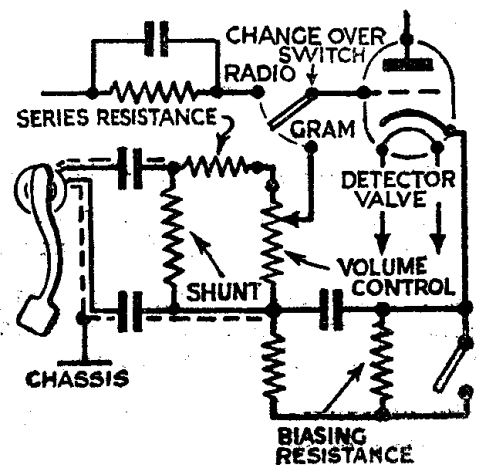

Fig. 6.

# SPARE PART LISTS

for Pick-ups from 1932 onwards.

Model.	Pick-up Part No.	Page	Model.	Pick-up Part No.	Page
17A ...	4344M ...	5	271 D.C. ...	4344S ...	7
19 ...	16100F ...	6	274 A.C. ...	16100D ...	7
254 A.C. ...	4344N ...	6	280 D.C. ...	16100Y ...	7
254 D.C. ...	4344S ...	7	290 A.C. ...	4344X ...	7
258 A.C. ...	3950E ...	7	291 A.C. ...	3950J ...	8
271 A.C. ...	4344N ...	7	291 D.C. ...	3950M ...	8

Part No.	Description.	Parts per Inst.	Finish.	Retail List Price.	Per
				£ s. d.	
<b>MODEL 17A (WITH LEADS).</b>					
<b>Model 17A.</b>	<b>Marconiphone Pick-up, Type 17, complete with fittings, packed in carton</b> ...	—	Std.	2 2 0	Each.
<b>4344M</b>	<b>Marconiphone Pick-up, complete with leads (only supplied complete in carton)</b> ...	—	BzP	—	—
4344A	Pick-up arm only ...	1	BzP	0 4 0	Each.
4345	Balance weight ...	1	BzP	0 1 4	"
8662	Screw securing balance weight ...	1	BzP	0 0 4	Doz.
4346A	Supporting bracket ...	1	BzP	0 2 4	Each.
7560	Pivot screw ...	1	BzP	0 0 7	Doz.
2257	Washer, on pivot screw, between arm and bracket ...	2	WN	0 0 1	"
12431	Fixing Base ...	1	BzP	0 1 6	Each.
4234	Retaining ring, holding balls ...	1	PF	0 0 6	Doz.
249	Ball ...	10	PF	0 0 1	"
4267	Lower ball race ...	1	CdP	0 0 4	Each.
4268	Lock nut, screws into bottom of support cap and holds lower ball race ...	1	PF	0 0 3	"
12432A	Pick-up lead, complete with rubber sleeves ...	1	Std	0 1 10	"
3083	Rubber sleeve—small ...	1	PF	0 0 6	Doz.
3084	Rubber sleeve—large ...	2	PF	0 0 6	"
2804	Retaining screw for pick-up head ...	1	BzP	0 0 7	"
<b>4326E</b>	<b>Pick-up Head, complete</b> ...	1	Std	1 5 0	Each.
4326B	Bakelite base of head with balls and terminal strip ...	1	Std	0 2 7	"
4327A	Terminal strip with tags ...	1	Std	0 0 5	"
7237	Tags for terminal strip ...	3	Tnd	0 0 4	Doz.
7962	Tube to hold spring and balls ...	1	PF	0 0 7	"
9089	Spring ...	1	WN	0 0 10	"
2246	Ball ...	2	PF	0 0 3	"
4331	Moving armature ...	1	CdP	0 1 2	Each.
10092	Bearing rubber for armature ...	2	PF	0 0 1	Doz.
4328A	Coil complete ...	1	Std	0 2 9	Each.
4329	Pole piece ...	2	CdP	0 2 5	Doz.
4332	Bolt securing pole piece ...	2	WN	0 0 5	Doz.
4333	Damping pad, rubber ...	1	PF	0 0 7	"
4334	Damping plate } securing damper pad ...	1	WN	0 0 8	"
2706	Screw ...	2	WN	0 0 7	"
3102	Magnet ...	1	CdP	0 4 3	Each.
4337	Stud ...	1	PF	0 0 2	"
4339	Screw } securing cover ...	1	BzP	0 0 4	Doz.
4338A	Cover (Marconiphone) with clamping rubber inside ...	1	Std	0 1 9	Each.
4335	Needle screw ...	1	BzP	0 0 2	"

**SPARE PART LIST—continued.**

Part No.	Description.	Parts per Inst.	Finish.	Retail List Price.	Per
				£ s. d.	
<b>MODEL 19.</b>					
—	<b>Marconiphone Pick-up, Type 19, complete with fittings, packed in carton (only supplied complete in carton)...</b>	—	—	1 12 6	Each.
16100F	<b>Pick-up complete with leads</b> ... ..	—	—	—	—
16100	Pick-up arm ... ..	1	PF	0 1 6	Each.
16125	Trade Mark insert ("Marconi") ... ..	1	PF	0 0 1	"
16120A	Pick-up head assembly ... ..	1	Std	0 10 0	"
16101	Pole piece ... ..	2	WN	0 1 9	"
16102	Damping rubber ... ..	1	PF	0 0 1	"
16103	Armature pivot ... ..	2	PF	0 0 6	Doz.
16104	Damping rubber clamp ... ..	1	WN	0 0 5	"
16126	Screw No. 6, B.A. $\times \frac{7}{8}$ -in., securing damping rubber clamp	2	WN	0 0 4	"
16106	Lead clamp ... ..	1	WN	0 0 7	"
16109	Armature ... ..	1	CdP	0 0 6	Each.
3154	Needle screw ... ..	1	BzP	0 0 1 $\frac{1}{2}$	"
16110	Magnet ... ..	1	PF	0 2 1	"
16111A	Armature coil bobbin assembly... ..	1	Std	0 1 4	"
16111B	Hum Neutralising coil bobbin assembly	1	Std	0 1 1	"
16113	Pole fixing screw ... ..	4	WN	0 0 8	Doz.
16118	Bracket supporting lead ... ..	1	CB	0 0 1	Each.
11238	Screw for lead clamp and bracket ... ..	1	BzP	0 0 2	Doz.
16119	Sleeve for lead ends ... ..	3	PF	0 0 10	"
16120	Pick-up head base ... ..	1	PF	0 0 9	Each.
16121	Pillar arm supporting Pick-up Arm ... ..	1	PF	0 0 8	"
16396	Fixing Base ... ..	1	PF	0 0 10	"
16107A	Spring and anchor rings ... ..	1	OB	0 0 2	"
16108	Anchor for above spring ... ..	1	WN	0 0 6	Doz.
16112	Soundbox fixing screw ... ..	2	WN	0 0 1 $\frac{1}{2}$	Each.
16114	Pivot screw ... ..	1	BzP	0 0 1 $\frac{1}{2}$	"
16115	Pad ... ..	2	PF	0 0 6	Doz.
16116	Lead cover ... ..	1	PF	0 0 1	Each.
11237	Screw for lead cover ... ..	1	BzP	0 0 5	Doz.
16117	Segment ... ..	8	WN	0 0 6	"
or 17001	Spacer for ball bearings ... ..	1	WN	0 0 3	Each.
3519	$\frac{1}{8}$ -in. ball bearings ... ..	8	PF	0 0 1 $\frac{1}{2}$	Doz.
16128	Locking screw... ..	1	BzP	0 0 8	"
<b>Fittings, etc., for Model 19 Pick-up.</b>					
12432A	Lead ... ..	1	Std	0 1 10	Each.
15969A	Pick-up arm rest with felt ... ..	1	Std	0 0 9	"
8602	Screw No. 4 $\times \frac{3}{8}$ -in. R.H.I., for rest ... ..	2	BzP	0 0 2	Doz.
9561	Screw No. 6 $\times \frac{1}{8}$ -in. R.H.I., for pickup ... ..	3	BzP	0 0 2	"
12986	Instruction leaflet ... ..	1	—	0 0 3	Each.
4893A	Envelope for rest and screws ... ..	1	—	0 0 7	Doz.
12996	Template ... ..	1	—	0 0 1 $\frac{1}{2}$	Each.
<b>PICK-UP AS USED ON MODEL 254 A.C.</b>					
4344N	<b>Pick-up and Arm complete, with lead and brake arm...</b> ... ..	—	—	2 0 0	—
	Identical with 4344M (see page 5) except for the following component parts:—				
4348	Support cap (the base of, which holds ball race) ... ..	1	BzP	0 1 11	Each.
2425	Stop screw } in back of support, restricting horizontal swing	1	BzP	0 0 7	Doz.
5624	Nut } of arm ... ..	1	WN	0 0 3	"
4956A	Brake arm and pin ... ..	1	BzP	0 0 8	Each.
2792	Screw, securing brake arm and pin to bottom of bracket (4346A)	2	WN	0 0 6	Doz.
12767	Pick-up lead complete with tags and rubber sleeves ... ..	1	Std	0 1 6	Each.
3083	Rubber sleeve ... ..	4	PF	0 0 6	Doz.
2353	Tag } on pick-up lead ... ..	1	Tnd	0 0 3	"
11802	Tag } ... ..	3	Tnd	0 0 3	"
4326E	<b>Pick-up Head, complete</b> ... ..	1	Std	1 5 0	Each.
	(For component parts see page 5.)				

**SPARE PART LISTS—continued.**

Part No.	Description.	Parts per Inst.	Finish.	Retail List Price.	Per
				£ s. d.	
<b>PICK-UP AS USED ON MODEL 254 D.C.</b>					
4344S	Pick-up and Arm complete, with lead and Brake Arm ... Identical with 4344N (see page 6), except for the following component parts :—			2 0 0	Each.
13787A	Pick-up lead complete with tags and rubber sleeves ...	1	Std	0 1 8	"
3083	Rubber sleeve } on pick-up lead ...	4	PF	0 0 6	Doz.
11802	Tag }	3	Tnd	0 0 3	"
7237	Tag, securing lead to terminal strip on head ...	1	CdP	0 0 4	"
<b>PICK-UP AS USED ON MODEL 258 A.C.</b>					
3950E	Pick-up and Arm complete ...	1	Bzp	1 15 0	Each.
3950D	Pick-up Arm only ...	1	BzP	0 7 6	"
2804	Screw retaining pick-up head ...	1	BzP	0 0 7	Doz.
10594	Pick-up lead, inside arm, from head to bush ...	2	PF	0 1 2	"
10573A	Pick-up arm bush, with two sockets and tags ...	1	Std	0 0 8	Each.
2851	Screw securing bush ...	2	WN	0 0 6	Doz.
4326E	Pick-up Head (for component parts see page 5) ...	1	BzP	1 5 0	Each.
<b>PICK-UP AS USED ON MODEL 271 A.C.</b>					
4344N	Pick-up and Arm complete, with Lead and Brake Arm ... Identical with pick-up for Model 254 A.C. (see page 6).			2 0 0	Each.
<b>PICK-UP AS USED ON MODEL 271 D.C.</b>					
4344S	Pick-up and Arm complete, with Lead and Brake Arm ... Identical with pick-up for Model 254 D.C. (see page 7).			2 0 0	Each.
<b>PICK-UP AS USED ON MODEL 274 A.C.</b>					
16100D	Pick-up complete with Lead and Brake Arm ... Identical with 16100F (see page 6), except for the following component parts :—	1	Std	1 12 0	Each.
14666A	Lead complete, with rubber sleeves and tags ...	1	Std	0 1 11	Each.
3083	Rubber sleeve ...	3	PF	0 0 6	Doz.
16122	Fixing Base ...	1	PF	0 0 11	Each.
16127A	Brake Arm and pin ...	1	BzP	0 0 11	"
11228	Screw securing pick-up arm... ..	3	BzP	0 0 4	Doz.
<b>PICK-UP AS USED ON MODEL 280 D.C.</b>					
16100Y	Pick-up complete, with Lead and Brake Arm ... Identical with 16100D (see page 7), except for 16111B Hum Neutralising Coil, which is not fitted.	1		1 11 0	Each.
<b>PICK-UP AS USED ON MODEL 290 A.C.</b>					
4344X	Pick-up and Arm complete, with Lead and Brake Arm ... Identical with 4344N (see page 6), except for the component parts as follows :—	1		2 2 6	Each.
13580A	Pick-up lead, complete with tags and plugs ...	1	Std	0 2 4	"
3451	Tag—large ...	1	CdP	0 0 6	Doz.
8812	Tag—small ...	1	CdP	0 0 6	"
8207B	Plug—black ...	2	Std	0 0 3	Each.
8207D	Plug—blue ...	1	Std	0 0 3	"
7237	Tag ...	1	CdP	0 0 4	Doz.
4326M	Pick-up Head complete ... Identical with 4326E (see page 5), with the addition of the following component parts :—	1	Std	1 7 6	Each.
3151A	Hum Neutralising Coil ...	1	Std	0 2 8	Each.
3149	Coil clip—R.H. ...	1	WN	0 0 9	Doz.
3150	Coil clip—L.H. ...	1	WN	0 0 9	"

**SPARE PART LISTS—continued.**

Part No.	Description.	Parts per Inst.	Finish.	Retail List Price.	Per
				<b>£ s. d.</b>	
<b>PICK-UP AS USED ON MODEL 291 A.C.</b>					
3950J	Pick-up and Arm complete Identical with 3950E (see page 7), except for Pick-up Head.	1	BzP	1 17 6	Each.
4326M	Pick-up Head—for component parts, see page 7	1	Std	1 7 6	„
<b>PICK-UP AS USED ON MODEL 291 D.C.</b>					
3950M	Pick-up and Arm complete, with Lead	1	BzP	1 15 0	Each.
3950G	Pick-up arm only	1	BzP	0 7 6	„
2804	Screw retaining Pick-up Head	1	BzP	0 0 7	Doz.
10682A	Pick-up lead with three plugs	1	Std	0 2 6	Each.
8207D	Plug—blue	2	Std	0 0 3	„
8207F	Plug—grey	1	Std	0 0 3	„
4326P	Pick-up Head	1	BzP	1 5 0	„
4328B	Coil	1	Std	0 2 9	„
Other component parts identical with 4326E (see page 5.)					

**KEY TO ABBREVIATIONS USED IN "FINISH" COLUMN.**

Bronze Polish	...	BzP
Cadmium Plate	...	CdP
Camera Black	...	CB
Oil Black	...	OB
Plain Finish	...	PF
Standard	...	Std
Tinned	...	Tnd
White Nickel	...	WN

In order to expedite delivery of spare part orders, please quote :—

1. Model number and unit type number.
2. Spare part number and description as given in the above list.
3. Quantity required.

Failure to give full particulars inevitably causes delay in the execution of orders.

Order spare parts from :—

THE SERVICE DEPARTMENT,  
THE MARCONIPHONE COMPANY, LIMITED,  
SHERATON WORKS, HAYES, MIDDLESEX.

Telephone : Southall 2468.

Telegraphic Address : Service, Hayes, Middlesex.