

# C-7

MOVING COIL CARTRIDGE HEAD AMPLIFIER

# Accuphase



The use of Moving Coil cartridges has become widespread spectacularly in recent years. This is because Moving Coil cartridges, which produce superior sound, are now less expensive than they were before. Another reason, which must not be overlooked, is the advent of better head amplifiers with superior characteristics. Such head amplifiers are available today as separate units, as well as integrated into certain amplifiers and preamplifiers so that Moving Coil cartridges can be readily used. These developments have hastened the growing popularity of these cartridges.

Some audio fans, however, advocate the use of step-up transformers with Moving Coil cartridges for best performance. Although it is true that high quality transformers may produce their own distinctive sound characteristics, high grade head amplifiers reproduce more faithfully the original sound and atmosphere of the cartridge. The Accuphase C-7 Stereo Head Amplifier was developed to reproduce accurately the true characteristics of Moving Coil cartridges, and represents the essence of technology acquired in developing the C-240 stereo preamplifier.

## C-7 GUARANTY SPECIFICATIONS

### PERFORMANCE GUARANTY:

All Accuphase product specifications are guaranteed as stated.

**VOLTAGE AMPLIFICATION:** 26 dB

**FREQUENCY RESPONSE:** 5 – 100,000 Hz (+0, -0.2 dB)

**MAXIMUM INPUT VOLTAGE:** 35 mV RMS  
(20 – 20,000 Hz, 0.002% distortion)

**TOTAL HARMONIC DISTORTION:** Lower than 0.002%  
(20 – 20,000 Hz, at maximum input)

**HUM AND NOISE:** 72 dB (IHF-A through RIAA equalization,  
at 0.1 mV input)

**INPUT IMPEDANCE:** 100 Ohms

**OUTPUT IMPEDANCE:** 100 Ohms

**SEMICONDUCTOR COMPLEMENT:** 26 Tr's, 9 FETs, 2 ICs, 8 Di's.  
**POWER REQUIREMENT:** Compatible 100/117V and or 220/240V,  
50/60 Hz, 5 Watts.

**DIMENSIONS:** 102 mm (4-0 inches) wide,  
61 mm (2-7/16 inches) high,  
350 mm (13-13/16 inches) deep.

**WEIGHT:** 2.5 kgs (5.5 lbs) net,  
3.9 kgs (8.6 lbs) in shipping carton

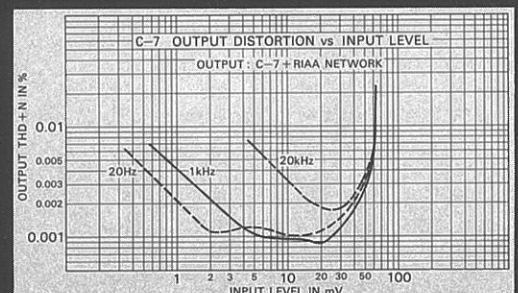

# Accuphase C-7

MOVING COIL CARTRIDGE HEAD AMPLIFIER

## 1 SYMMETRICAL, CLASS-A PUSH-PULL, DC AMPLIFIER UTILIZES RETs AT SIGNAL INPUT

The Accuphase C-7 Stereo Head Amplifier uses the same basic head amplifier circuitry as the Accuphase C-240 as shown in Figure 1. It is a push-pull differential type, DC amplifier which employs four RETs at the signal input. RET is the abbreviation for Ring Emitter Transistor, which is constructed so that its internal circuit is equivalent to a great many small signal transistors working together in parallel.

RETs were originally developed to provide power amplification for superior high frequency characteristics. The RETs used for the C-7 were further developed to ensure superior linearity at low operating levels. Therefore, an ideal head amplifier input circuitry with exceptionally low noise was achieved by utilizing their superior characteristics and construction that makes an RET equivalent to a large network of many transistors working in parallel.

## 2 MAIN AMP CIRCUITS ENCAPSULATED INTO MODULES

The main amplifying circuits, including active devices and associated elements are mounted on a printed board, and encapsulated with special thermal epoxy into separate modules channel by channel. As a result these sections are completely sealed off from air contact which, not only ensures longer life, but promises very stable operation against wide temperature and humidity changes.



## 3 ICL (Input Capacitor-Less) SYSTEM FOR BETTER SOUND

Since a head amplifier's input circuits must handle extremely low level signals, they must also have equivalent low noise characteristics. The ordinary way to achieve this is to reduce input impedance to the lowest value possible. This, however, requires a large input coupling capacitor, and poses the problem of sound coloration, since it is difficult to perfect large, high quality capacitors that do not introduce coloration.

To avoid the harmful effects of sound coloration, the input capacitors have been eliminated altogether in the C-7 by perfectly balancing its input differential circuits. Therefore, highest fidelity can be expected because the Moving Coil cartridge's low level output can be fed directly to the C-7's RET amplifying devices.

## 4 LOW IMPEDANCE POWER SUPPLIES

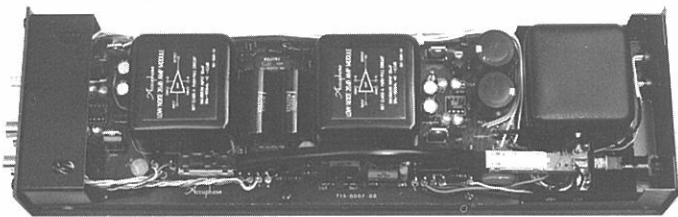

Since the head amplifier must handle very small signals, it is the power supply that controls its performance stability. Therefore, the C-7 is provided with two voltage regulated power supplies, one each for the left and right channels, that are located near the amplifier modules. They ensure very stable operation as they maintain low impedance characteristics over a wide range.

## 5 BY-PASS SWITCH PROVIDED FOR OTHER TYPE CARTRIDGES

A head amplifier is not required when Moving Coil cartridges are not used, so a By-Pass Switch is provided which directly connects the input and output terminals as shown in Figure 2. This permits the use of other type cartridges without having to reconnect input pin plugs.

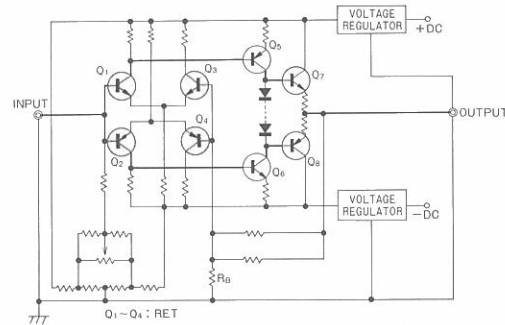

Fig. 1. RETs' SYMMETRICAL PUSH-PULL, CLASS-A, DC AMPLIFIER

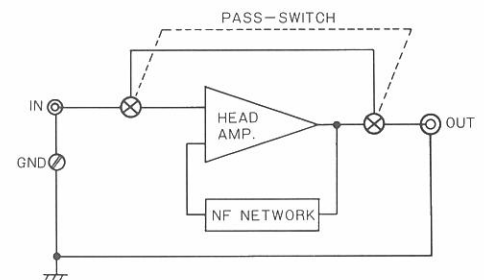

Fig. 2. DIAGRAM OF C-7

### RELATION BETWEEN CARTRIDGE OUTPUT IMPEDANCE AND INPUT IMPEDANCE OF HEAD AMPLIFIER

A head amplifier's input impedance becomes the load impedance of a Moving Coil cartridge that is connected to it. In other words, the cartridge represents the power generating element in relation to its load which corresponds to the head amp's input impedance.

In such a relationship, the value of the load impedance must not hinder the full operation of the power generating action. The relation can be likened to that between an amplifier's output impedance and the impedance of speaker. The general principle in determining impedance values for best performance in such relationships is that the load impedance should be several times that of the output impedance.

An input impedance of 100 ohms was decided for this head amplifier. It was chosen as a suitable load for the low 2 to 3-ohm impedance type Moving Coil cartridges, as well as the high 40-ohm impedance cartridges, as a result of extensive listening tests with all types of Moving Coil cartridges.

Sound quality is marred by a sense of oppression and bass response is weakened when the load impedance becomes too low. This is because a load causes excessive damping against vibrations of the cartridge's moving elements.

**Accuphase**  
KENSONIC LABORATORY INC.