

AR

**TURNTABLE
EB101**

**Owner's
Manual**

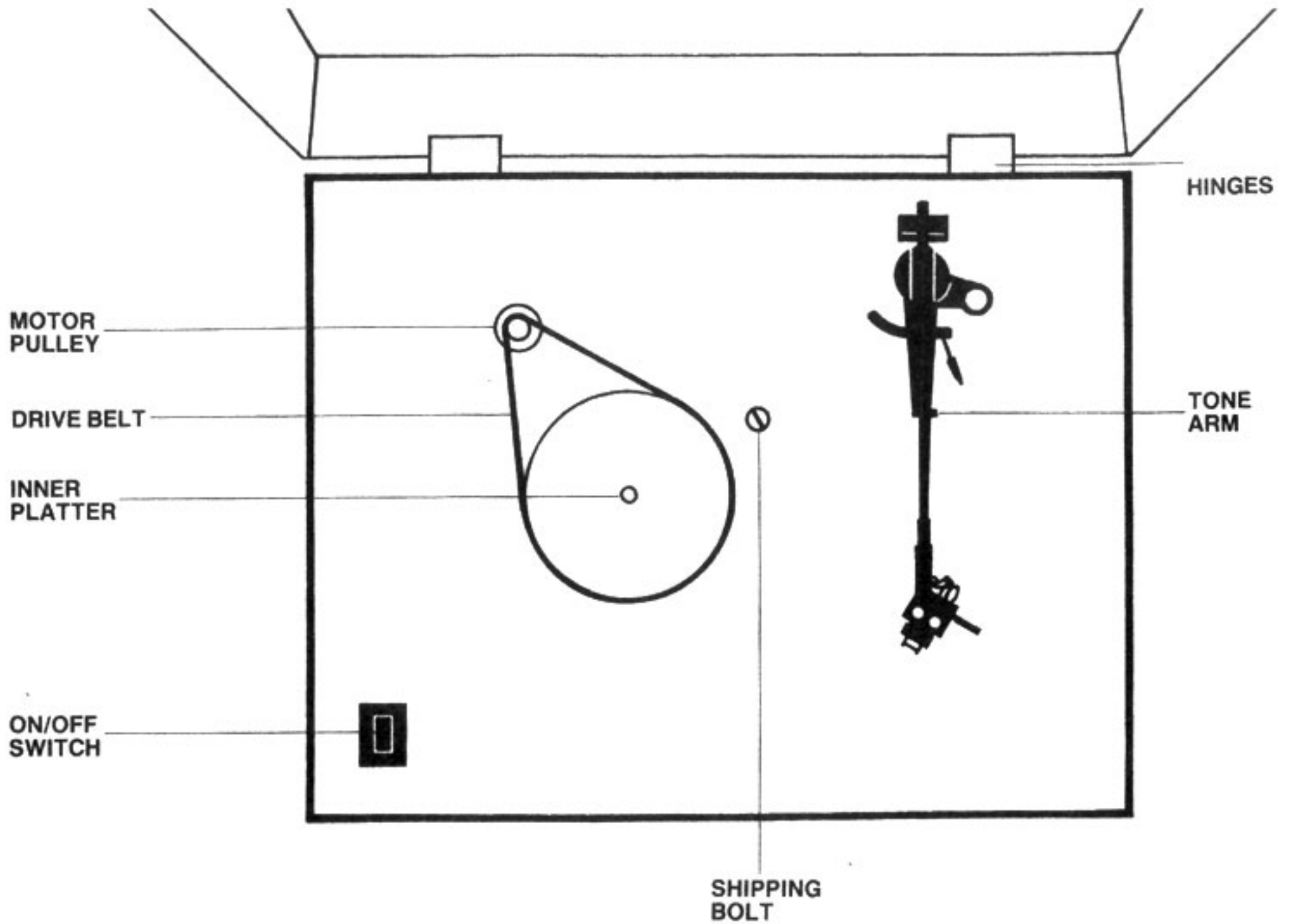

Fig 1. EB101 TURNTABLE LAYOUT WITHOUT OUTER PLATTER IN PLACE.

EB 101 turntable manual

Congratulations on purchasing your AR turntable. It is a precision instrument, capable of providing enjoyable, accurate reproduction of recorded music. For optimum performance, it is worthwhile taking a few minutes to read this manual prior to use.

A) Setting up your EB101 turntable

This section and the next deal with setting up an AR turntable purchased complete with AR tone arm. If you purchased a unit *without* tone arm and intend fitting another of your choice, then proceed as instructed in the separate instruction sheet 'Fitting alternative tone arms'. Then follow the appropriate instructions below.

1) Carefully remove the parts from the packing, remembering to retain all the packing pieces in case the turntable should ever need returning to AR for repairs.

Remove the packing pieces from under the small inner platter. **THESE MUST BE REPLACED IN SITU BEFORE THE TURNTABLE IS SHIPPED**, so retaining these is particularly important.

2) Unscrew, remove and *retain* the shipping bolt located on the top of the plinth as shown in fig 1.

3) The drive belt is shipped on the inner part of the platter and before you put the outer platter on the inner platter, the belt must be positioned on the motor pulley.

To do this, first make sure your fingers are free of oil or grease, as contamination can seriously affect the turntable's performance. Then, simply pull the belt away from the inner platter and place it over the appropriate section of the motor pulley, making sure the belt is not twisted as shown in fig 1.

Use the large-diameter section for 45rpm and the small-diameter section for 33 $\frac{1}{3}$ rpm.

4) Place the hole in the large outer platter over the spindle in the inner platter and gently lower the outer platter making sure it fits securely.

5) Place the felt mat on the platter. If it has become slightly uneven during packing and transportation, the felt will soon level itself out in use. Severe creases can be removed with a warm iron.

6) If your EB101 turntable has been factory fitted with the AR

tone arm it will have been adjusted to suit. If you wish, you can check the adjustment as outlined in the separate section 'Fitting alternative tone arms' though it should not be necessary. However, if you fix an alternative arm to the EB101 you *must* go through the procedure set out in the separate tone-arm fitting section.

B) Setting up your AR tone arm

1) Remove the counterweight from its packing. Mount it onto the tone arm's rear spindle with the white numbers to the front, by simultaneously pushing and rotating it anti-clockwise as viewed from the front as shown in fig 2.

FIG 2

HOW TO SET THE TRACKING FORCE

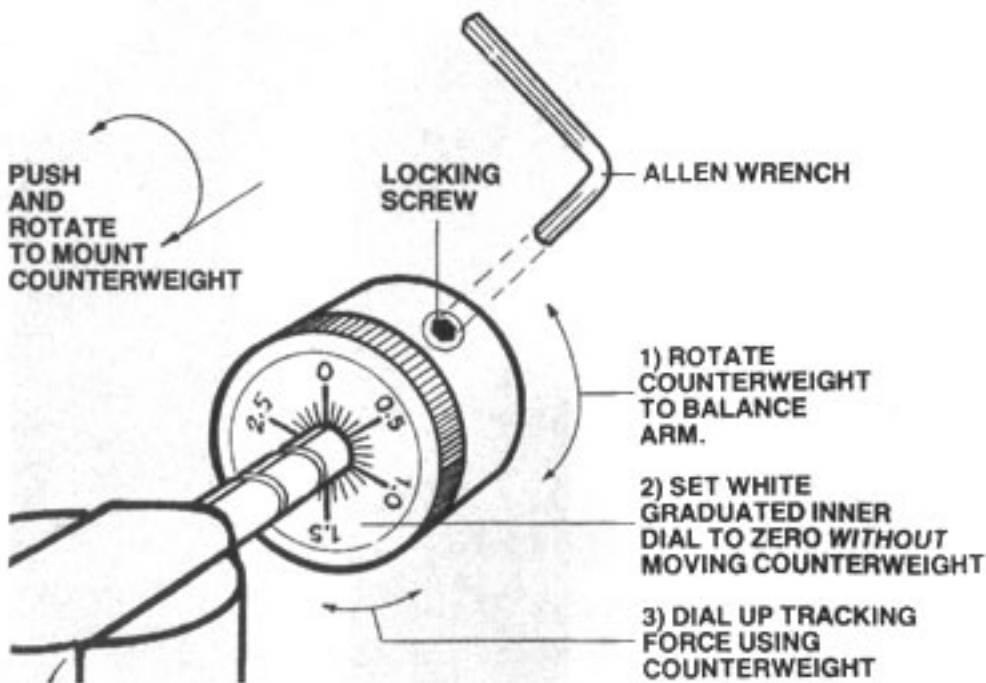

2a) If your EB101 turntable has been factory-fitted with a cartridge, all you need to do is set the tracking force and bias as described below.

However, if you wish to fit your own cartridge, you must first mount and align it as described in section (C) 'Cartridge alignment' then continue as in 2b)

2b) Before setting the tracking weight to the recommended amount (2 grammes for the AR cartridge) you must set it to zero as follows.

Set the bias compensation to zero using the small bias dial to the side of the arm pillar (fig 3). Release the arm from its rest and rotate the counterweight by its outer diameter until the arm floats freely in a horizontal position, (Fig 2). The arm will then be balanced to zero. *Without moving the counterweight on the spindle*, rotate only the knurled calibrated dial relative to the counterweight until '0' aligns with the white line on the spindle.

Now rotate the whole counterweight, together with the calibrated dial, anticlockwise (as viewed from the front), holding the outer diameter again, until the appropriate tracking force registers on the dial adjacent to the white line. The tracking force will now be set and should be locked gently but firmly by means of the small Allen screw in the counterweight as shown in fig 2.

Always follow the makers' tracking force recommendations, and remember that optimum tracking and minimum record wear will usually be achieved with a setting closer to the high end of the suggested range than the low end.

3) Now simply set the bias compensation by dialling to the same figure as used to set tracking weight, but using the small calibrated knob to the side of the arm base as shown in fig 3.

4) Place a record on the platter, with the felt mat in situ, and lower the stylus on to the record. Check whether the arm is parallel to the record by viewing it at record level.

If it is not, place the arm back in the arm rest and loosen the Allen screw in the arm-pillar locating collar with the Allen wrench supplied (see fig 4). You may now adjust the arm height, lightly tighten the Allen screws, and check with the stylus on the record. Once the height is correct, you should firmly tighten the Allen screws in the collar to grip the arm pillar.

FIG 3

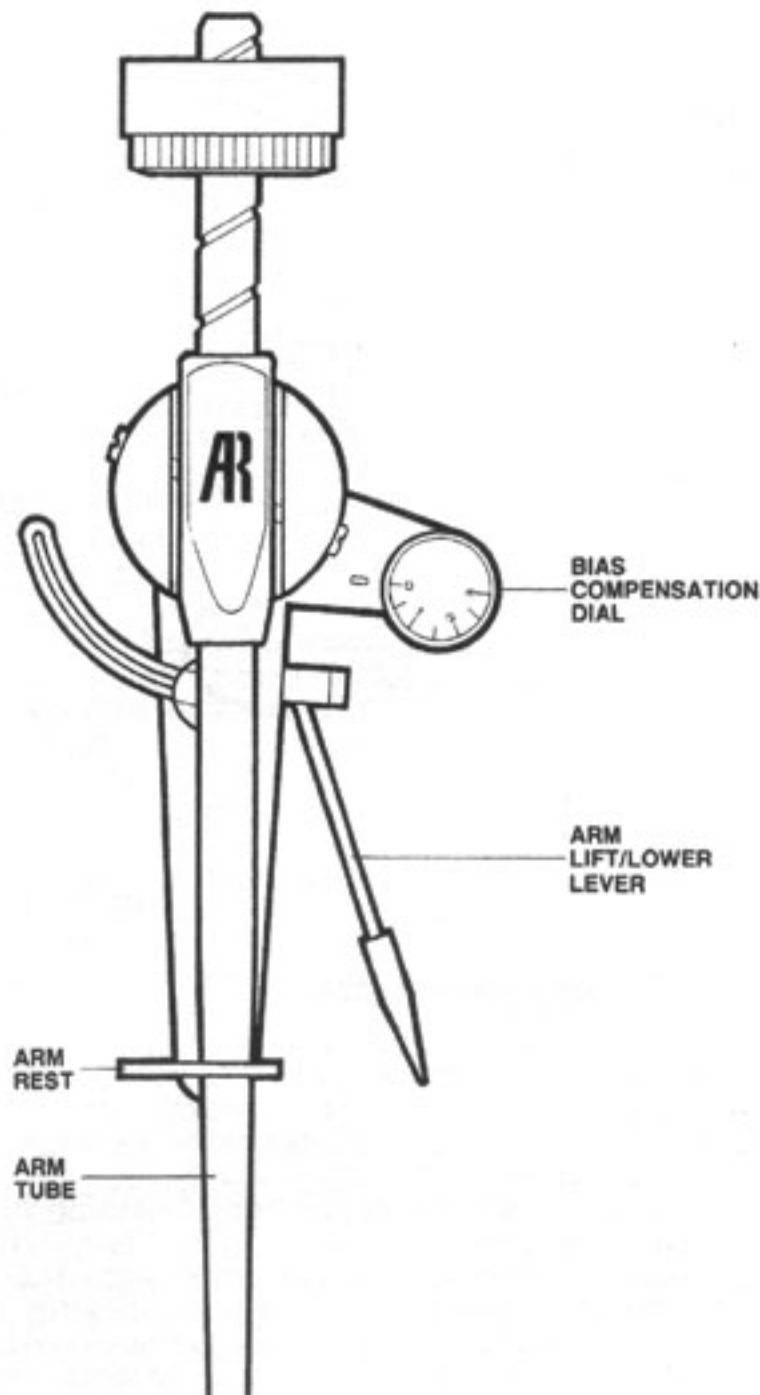
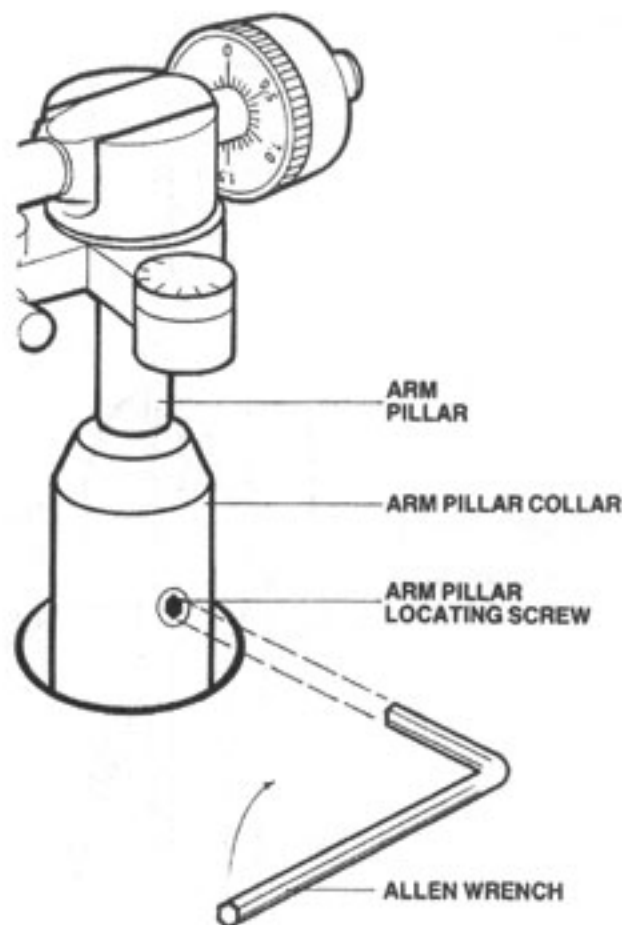

FIG 4

**ALLEN SCREWS
GRIP ARM PILLAR
AND ALLOW FOR
VERTICAL
ADJUSTMENT**



C) Cartridge alignment

1a) You will only need to align the cartridge with our dual-point protractor if you are fitting your own, in which case proceed as described below in 1b) If your turntable has been factory-fitted with a cartridge, ignore this section and continue with section E 'Installation and use'

1b) First fit the cartridge into the headshell using the 1/2 inch fixing slots in the headshell as shown in fig 5a. Use metal bolts and nuts (preferably steel) to hold the cartridge in place, but initially locate the cartridge with the bolts only finger-tight so that the cartridge may be moved about in the headshell. You should also fit the small female connectors which are on the signal wires over the

pickup cartridge's pins as shown in Fig 5b. Sometimes these sockets may need to be gently squeezed with pliers for a firm fit. Follow the colour code: red right signal, green right earth, white left signal, blue left earth. It is often easier to do this *before* mounting the cartridge in the arm.

2) Set the tracking force to roughly one gram (fig 2) and the bias compensation to zero as in B2b and B3, (fig 3) but don't lock the counterweight.

3) Place the dual-point stylus protractor's hole over the record spindle and push down onto the felt mat. Gently lower the stylus on to the small cross at the alignment point nearest to the centre bearing as shown on the protractor.

Look at the cartridge in the headshell: the sides and front of the cartridge should be aligned squarely with the lines on the protractor. The cartridge should be 'square' in the headshell and the headshell should align squarely with the lines as indicated on the protractor.

If cartridge and headshell do not both align, then raise the tone arm off the protractor and, taking great care not to damage the delicate stylus assembly, move the cartridge forwards or backwards as appropriate, keeping the cartridge 'square' in the headshell, until it lines up.

With cartridges which have non-parallel sides and/or fronts you will have to judge the alignment by eye as carefully as possible.

With this done, raise the arm off the protractor and rotate the platter slightly to line up the stylus over the outer alignment point as shown on the protractor. If the cartridge has been properly positioned, it should line up exactly square here. If however, there is an error, correct for it by re-positioning the cartridge in the headshell until it lines up at the outer point and re-check it at the inner one.

The idea is to achieve perfect alignment as judged by eye at both points. When you are satisfied, raise the arm, carefully tighten the cartridge-mounting bolts taking great care not to move the cartridge, lower again and re-check.

The AR dual-point alignment gauge can also be used with other turntables and arms for optimum cartridge performance over the record's playing surface, regardless of arm geometry, but with many arms the best alignment will be obtained when the cartridge is not exactly square in the headshell (though, of course, the cartridge must align with the protractor lines).

CARTRIDGE FIXING

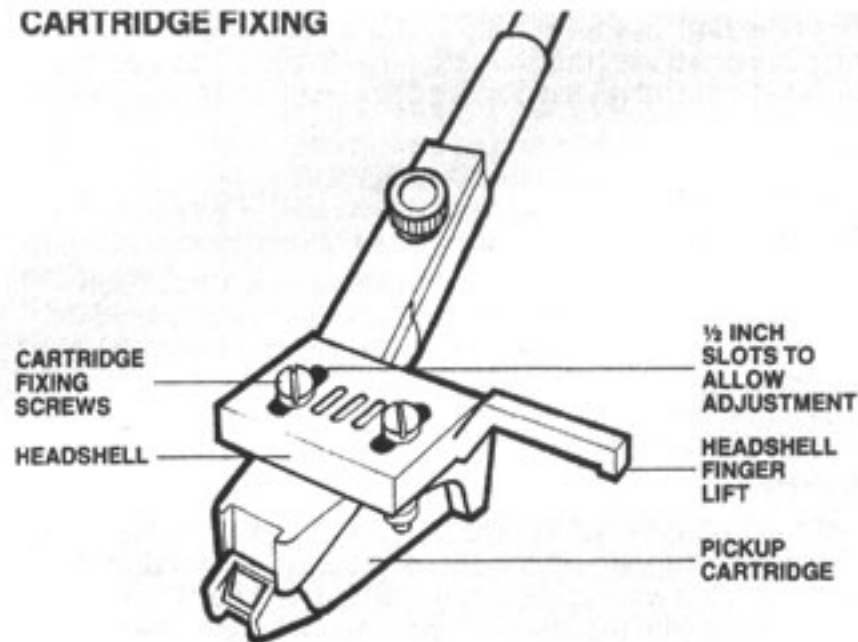
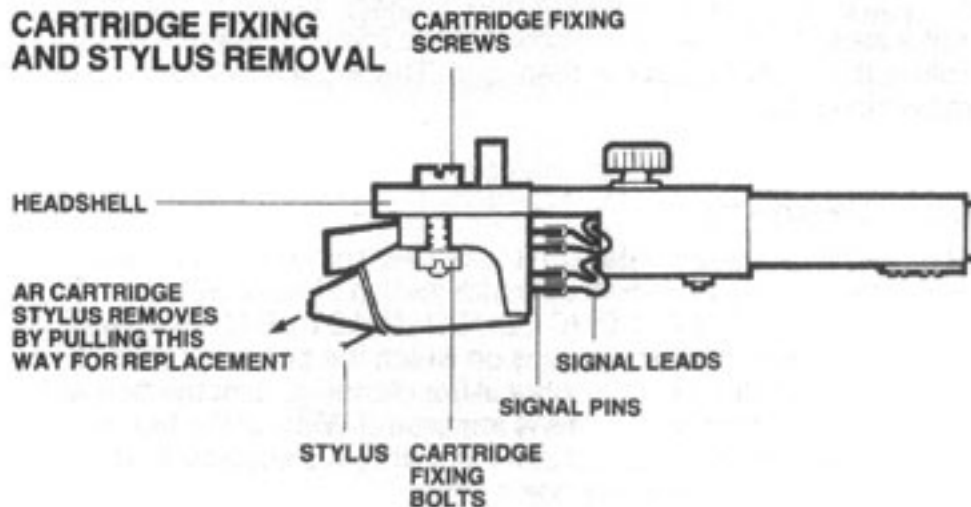

FIG 5b

CARTRIDGE FIXING AND STYLUS REMOVAL



phono plugs on the end of the arm's leads into the phono input of your amplifier or receiver (red for right and black for left). Most AR tone arms do not have a separate signal earthing lead, but if your arm has one it should be gripped under the grounding, or earthing tag on your amplifier or receiver to avoid the possibility of unwanted background 'hum' (a sort of deep-toned droning noise). In some set-ups you may experience minimal hum with the tag *not* connected and if this is the case for you, then the turntable may be operated with the signal earth tag disconnected. Otherwise you should operate the turntable with the earth lead connected at all times. It is important not to confuse the signal earth with the mains earth. Some EB101 turntables are provided with a three-core mains lead which has a yellow/green striped earth wire. The turntable should *never* be operated without this lead connected to the mains earth (for instance by disconnecting it at the mains plug).

Other EB101 turntables have a two-core mains lead with no mains earth. These do not require a mains earth and you should not attempt to connect one to your turntable.

2) Your EB101 turntable should be placed on a suitable surface close enough for the phono lead to reach the amplifier or receiver. It should *not* be extended with extra cable, or sound quality could suffer.

The suspended 'T-bar' subchassis makes the EB101 inherently immune to external vibration and so it will sound better than other decks in its price class, regardless of where you place it. However, in analytical audio systems the sound can be further enhanced by placing your turntable with care. You will find that the music will be easier to follow and more cleanly defined if you avoid placing the turntable on hollow cupboards (which can resonate). Best results will be obtained on a small, suitably light yet rigid and non-resonant table.

There are some purpose-built tables on the market, but you can experiment with different turntable positions to suit your own domestic environment.

2) You should connect your EB101 turntable to the mains supply by means of a good-quality mains plug. If plug is not supplied follow the appropriate diagram on the first page of this manual *precisely* for your own safety.

Before plugging in to your mains supply, check that your turntable is set to the correct voltage and frequency for your local mains supply. These settings should be marked on the carton. If you are in any doubt about the voltage and frequency of your turntable **DO NOT CONNECT THE TURNTABLE TO THE SUPPLY. DO NOT ATTEMPT TO USE IT** but refer to your dealer or local distributor for checking. Do not attempt to check yourself by dismantling the turntable. Leave this for the experts.

3) Now you may plug your EB101 turntable in and use it.

To play a record, turn on using the on/off switch located on the front left-hand side of the plinth top. Records may be placed on to, or removed from the platter while it rotates if you wish.

The arm can be raised or lowered gently on to the record using the damped lift/lower device on the AR arm as shown in fig 3. Other arms usually have a similar arrangement.

Speed changing

4) Your EB101 turntable will play records at either $33\frac{1}{3}$ or 45 rpm. To change speed, first turn off the motor, then lift the outer platter off the inner platter. Then, making sure that your fingers are free from grease or perspiration, use them to move the belt from one section of the pulley to the other as appropriate. Make sure the belt is not twisted, see fig 6. Use the large diameter for 45 rpm and the small diameter for $33\frac{1}{3}$ rpm.

FIG 6 SPEED CHANGING

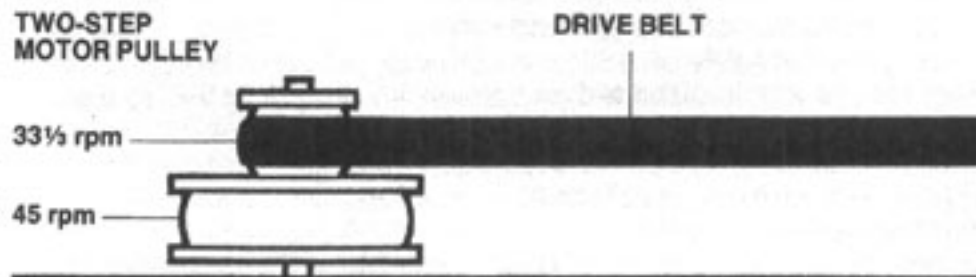

PLACE THE RUBBER BELT ON THE APPROPRIATE SECTION OF THE PULLEY

5) The smoked-acrylic dust cover supplied with your EB101 turntable fits directly into the two spring-counterbalanced hinges to the rear of the unit as shown in fig 1. It is a friction fit and slides into place, positioned with the slanting edge to the front. You may play records with the lid raised, lowered or removed as you prefer.

F) Maintenance Stylus cleaning

1) Keep the stylus free from dust by cleaning it with a small soft brush. Do *not* touch the stylus tip with your finger, or any solid object as the stylus, though hard, can be easily damaged along with the delicate cantilever assembly.

Stylus wear

2) The stylus will usually last for 500 to 1,000 hours of continuous playing. A worn or chipped tip will cause irreparable damage to your records. So, it's wise to regularly check and if necessary replace your stylus with the correct type when this becomes necessary.

Stylus replacement

3) If you ever replace your cartridge or check its alignment, first make sure the turntable is disconnected from the mains supply. Follow the manufacturer's directions. The AR stylus slides out as shown in fig 5b.

Belt cleaning

4) If any oily substance gets on to the belt, remove and clean it with a tissue or cloth moistened with methyl alcohol (wood alcohol), **RUBBING ALCOHOL SHOULD NOT BE USED**. The pulley and inner platter surfaces on which the belt rides should also be wiped clean with alcohol. After cleaning, dust the belt with ordinary talcum powder. This is important! Without the talcum powder the turntable will not start properly. We suggest that you clean and powder the belt once a year.

Lubrication

5) The main bearing will have been pre-lubricated at the factory and should not need any additional oil. However the bearing should be topped up occasionally (once a year is suggested), or if there is a loss of oil. First, remove the outer platter, then carefully withdraw the inner platter and bearing taking great care not to touch or get dirt or dust on to the bearing spindle. Then add oil to the bearing hole. Use only a few drops of the specially-formulated main-bearing oil available from your AR dealer or distributor. Do not over-fill:

Remember the bearing shaft will take up a lot of space in the bearing housing. If you add too much oil, it will be forced out in to the turntable and could cause damage.

Take care not to get oil on the drive pulley or belt and if you spill any on to the plinth this should be mopped up with tissue and wiped clean.

Re-assemble the bearing and wash your hands thoroughly before replacing the belt on the appropriate pulley section, then replace the outer platter and felt mat. No other parts need lubrication. You should *not* attempt to oil the arm or motor bearings!

Cleaning

6) On the dust cover use any non-abrasive liquid detergent or window cleaner sparingly.

The plinth should be cleaned with a propriety furniture polish or simply a dry duster.

Do not use any solvent-based cleaners on the EB101's plinth or cover.

The AR turntable full one year warranty Warranty coverage

AR warrants that the AR EB101 turntable and tone arm shall be free of defects in materials and workmanship for a period of one year from the date of purchase. This warranty covers parts, repair, labour and surface freight to and from the factory or the nearest Authorised Service Centre. New packaging is also free if needed (please ask in advance).

Legal rights

This warranty gives you specific legal rights and you may have other rights which vary from state to state. The liability of Acoustic Research will be limited to the purchase price of the product and they will not be liable for any incidental or consequential damages. Some states do not allow the exclusion or limitation of incidental or consequential damages, so the above limitation may not apply to you.

Exceptions and Exclusions

The AR EB101 turntable full warranty does not cover damages caused by abuse, misuse, accidents or improper wiring.

To obtain Warranty Service

In order to obtain warranty service, address written notice of the supposed defect to Teledyne Acoustic Research, 330 Turnpike Street, Canton Mass 02021 USA, or High St. Houghton Regis, Dunstable, Bedfordshire. LU5 5QJ. England.

Include a copy (not the original) of your bill of sale with your letter. alternatively, you may contact a local or convenient Authorised Service Agent directly. a list of all Service Agencies authorised to perform in-warranty service on AR products is packed with your turntable. The list is available on request from Acoustic Research.

Note

Acoustic Research reserve the right to change the equipment described herein without notice.

EB101 Turntable specifications

Drive system:	Belt drive.
Motor:	12-pole synchronous motor, 500 rpm at 50Hz, 600 rpm at 60Hz.
Speeds:	33 $\frac{1}{3}$ and 45 rpm.
Platter:	1.8kg (3.9lb).
Suspension:	Arm and platter are on fully isolated sub-chassis formed by pressed-steel 'T-bar' spring-suspended and damped at three points.
Wow and flutter:	0.05% (DIN 45507).
Rumble:	-72dB (DIN 45539B).
Mains voltage:	110-120V or 220-240V 50Hz or 60Hz.
Power consumption:	9 watts.

Tone arm specifications

Effective length:	229 mm
Overhang:	16 mm
Friction:	Less than 100 mg horizontal or vertical.
Effective mass:	12 grams.
Cartridge weight range:	3 to 9 grams.
Tracking force range:	0.5 to 3 grams.
Headshell:	Fixed or plug-in aluminium die casting.

 **TELEDYNE ACOUSTIC RESEARCH**

330 Turnpike Street, Canton/Mass 02021 USA.
High Street, Houghton Regis, Dunstable, Bedfordshire
LU5 5QJ England.