

AMPEX ELECTRIC CORPORATION

HOWARD AVENUE AT LAUREL • SAN CARLOS, CALIFORNIA

ORIGINAL 201

SHOP COPY

HOLLYWOOD & VINE P. O. BOX 2391 HOLLYWOOD 28, CALIF.

COMPANY	DEPT.



TO:

**ELECTRONIC
MAINTENANCE
FILE**

MODEL 201 CONVERSION

Model 201 Conversion Kit consists of the following:

Head Assembly MP-475-3

Playback Amplifier MP-667

Record Amplifier MP-666

Power Supply MP-656

The kits are shipped in sets. If these sets are not broken, no electronics adjustment will be necessary. If these sets are broken, minor level adjustments may be necessary as well as Bias and Noise Balance adjustment on record. Great care has been taken to maintain maximum possible uniformity in all components.

INSTALLATION:

Remove Record Chassis, Playback Chassis, and Power Supply Chassis from Model 200 Recorder. Remove playback cable from top plate by removing the two Allen-head screws. Remove old Head Assembly. Remove Gutter Pad.

Install new Playback Cable assembly with Allen-head screws used to hold the old cable in place on the top plate. A plastic clip has been included with the cable assembly and should be used to fasten the center of the cable to the center of the shelf in the cabinet. This is to prevent the cable from coming into close proximity with the drive motor, and thereby prevents the injection of hum into the playback system from same.

Next, plug in the new head assembly and bolt in place with the two 1/4 inch Allen flat head bolts supplied.

Plug in new power supply and amplifiers. Plug erase, record, and playback cables in same. Make sure that record and erase cables have not been interchanged. Plug in strapped plug in place of 10 or 16 Db. pad in gutter.

OPERATION:

The record Level control has been set to effect proper record level on MMM lll tape when the machine is bridging a † 4 VU Program Bus. The playback level is adjusted to play a tape so recorded at a level of † 4 VU into a 600 ohm terminated line. Both input and output lines may be either balanced or unbalanced. It is assumed that the machine has a strapped plug in the gutter. (0 db. attenuation)

ELECTRONICS ALIGNMENT

The machine is normally adjusted for MMM 111 tape.

1. Playback Amplifier. Two controls are provided on the playback amplifier. These are the 15 inch High Frequency Equalizer and the Playback Level Control. The first is used in conjunction with the new 15 inch standard tape. The level control can be adjusted for output levels up to plus 10 VU. The amplifier will deliver plus 30 dbm, with less than one percent harmonic distortion. A special equalization switch position has been incorporated to allow playback of old Model 200 tapes.

The playback head is critically damped within the head assembly and no further adjustment is necessary at 30 inch speed.

The output level is adjusted such that standard tape level is 10 db. below program.

II. Record Amplifier - Erase and Bias Supply.

1. Erase Adjustment. Plug an A.C. VTVM (such as Hewlett Packard 400) into erase current phone jack. Adjust erase current by means of the high frequency amplifier control located in back of the 6L6 tubes. The meter must read 2.3 to 2.5 volts RMS which is equivalent to 230 to 250 Ma. erase current. (Do not set at maximum.) Adjust head trimmer for maximum current. Readjust the high frequency amplifier control if necessary.

2. Bias Adjustment. Move meter plug to bias - record current jack. Adjust bias control for .52 volts RMS (equiv. to 5.2 Ma. bias current).
Note: This adjustment is approximate and preliminary only.

Connect audio frequency generator to input of machine. Set machine into operation in the record position. Set generator at 1000 cycles and adjust record level control so that standard tape level (10 db. below program) is effected on playback. Re-adjust bias for maximum output. ~~Then rotate clockwise to reduce~~

3. High Frequency Equalizer Adjustment. Remove one of the 6C5 tubes located in back of the 6L6 tubes. This will disable the oscillator and allow the record current to be read on the meter as set up under Bias Adjustment. Set meter to .03 volt scale. With the generator as connected before, set high frequency equalizer controls for curves as shown on curve sheets. Replace 6C5 tube in socket. Remove meter plug.

4. Record Level Adjustment. With generator connected as before, set generator output for 10 db. below program bus level at 400 cycles. Set machine into operation in the record position and adjust record level control to effect standard tape level on playback. Remove generator.

5. Noise Balance Adjustment. Short input terminals. Set machine into operation in the record position. Adjust control slowly for minimum noise on playback. This concludes the record amplifier adjustment.

THE ELECTRICAL PERFORMANCE SPECIFICATIONS OF AMPEX MODEL 201 RECORDER

Designed to be used on any tape - factory adjusted for M.M.M. 111 tape.

Noise at least 60 db. below 2% total harmonic distortion measured at 400 cycles per second on 111 tape.

Frequency response:

30"/sec. \pm 1 db. 50 to 15,000 cycles

15"/sec. \pm 2 db. 50 to 15,000 cycles

Input: bridging or matching, balanced or unbalanced line, normally set for \pm 4 V.U. Can be adjusted for any level above - 15 V.U.

Output: normally set for \pm 4 V.U. Amplifier will deliver \pm 28 d.b.m. at 4% intermodulation distortion.

- Features:
1. Smooth, stable frequency response. 15" curve same as AMPEX Model 300. For playback of other machines see curves attached.
 2. Amplifiers set up on easy-to-achieve response curves.
 3. Heads held to narrow tolerance to achieve complete interchangeability of head assemblies and amplifiers.
 4. Extremely low under-signal noise due to new type of head housing with minimum friction on tape.
 5. Narrow tolerance guides for uniform tape alignment which assures uniform high frequency output.
 6. Hum: Virtually eliminated by D. C. heaters throughout and multiple alloy shields on heads.
 7. Facilities for addition of accessory Meter Control Panel provides metering H. F. Bias Current, Erase Current, Record Current, Record Level, and Output Level. Step controls for controlling Record Level, and Line Level Output.
 8. Phone jack output for Record Current, Bias, and Erase Current provides for ready metering of these currents.
 9. Heads placed on same side of tape as AMPEX Model 300 to agree with standard adopted by NAB.

10. Complete voltage-regulated power supply assures uniform amplification and stable Bias and Erase oscillator regardless of changes in line voltage.
11. Push-pull oscillator driving push-push class A amplifier for extremely quiet Bias and Erase supply that is uncritical to adjustments.

HEAD HOUSING

The head housing, see Fig. 5, is a die cast assembly which contains the three heads used in the recording process. The heads are respectively erase, record and playback as viewed from left to right when facing the machine. The gate on the housing holds the playback and record shield covers and the tape-lifting fingers. The function of the tape-lifting fingers is to remove the tape from the heads when the gate is open during Rewind or Fast Forward operation. This reduces head wear considerably. The tape may leave a deposit on the heads if allowed to contact them at high speeds. Such a deposit will seriously impair the performance of the machine and should be guarded against by always opening the gate on Fast Forward and Rewind. If a deposit is left, it may be easily removed with carbon tetrachloride on a soft rag. Never use metal of any kind to touch the head surfaces.

HEAD ALIGNMENT

Remove the top cover from the head housing by removing the two screws from the top of same, and pulling cover gently back and up.

Looking at the head housing from the front, the three heads from left to right are: erase, record and playback.

The azimuth angle of the erase head requires no adjustment, and should not be touched.

The record and playback heads should be aligned only after reading and fully understanding the procedure under ELECTRONICS ALIGNMENT.

The actual physical alignment of the record and playback heads consists of placing a 1/4" spintite socket wrench on the left hand elastic stop nut in each head and adjusting back and forth until the proper azimuth angle is arrived at. This is accomplished by first playing the standard tape and adjusting the playback head until maximum response is obtained on the 15,000 cycle tone. The record head is then aligned with the playback head by recording 15,000 cycles on a blank tape, and adjusting the record head for maximum playback output.

HEAD DEMAGNETIZATION

Occasionally the heads become magnetized through some electrical fault which may occur in the amplifiers or by coming into physical contact with a magnetized object. In order to demagnetize these heads completely in such events, a demagnetizer should be used. A demagnetizer suitable for this purpose is manufactured by AMPEX as an accessory item. In the event, however, that time does not permit the owner of the machine to wait for delivery of a demagnetizer, he may make one as follows: Cut a piece of transformer lamination to a $\frac{1}{4}$ " x 2" size. Wrap the strip of metal with suitable insulating material and wind approximately 400 turns of No. 36 wire and attach a 4' length of 2 connector cord. Bend the iron strip into a "U" shape and bring the ends of the "U" to a spacing of $\frac{1}{4}$ ". Connect to a 6 volt source of A.C., open the gate on the head housing and bring the ends of the "U" in contact with the 2 poles on the magnetized head. Remove the demagnetizer very slowly, allowing the A.C. field to die off gradually. Repeat this operation on record and playback heads only, as the erase head will demagnetize itself. In the event demagnetization is not effected, repeat the process more carefully.

The capstan may become magnetized by contact with a magnetized tool. Should this occur it may be demagnetized with an A.C. solenoid placed over the shaft and slowly pulled away.

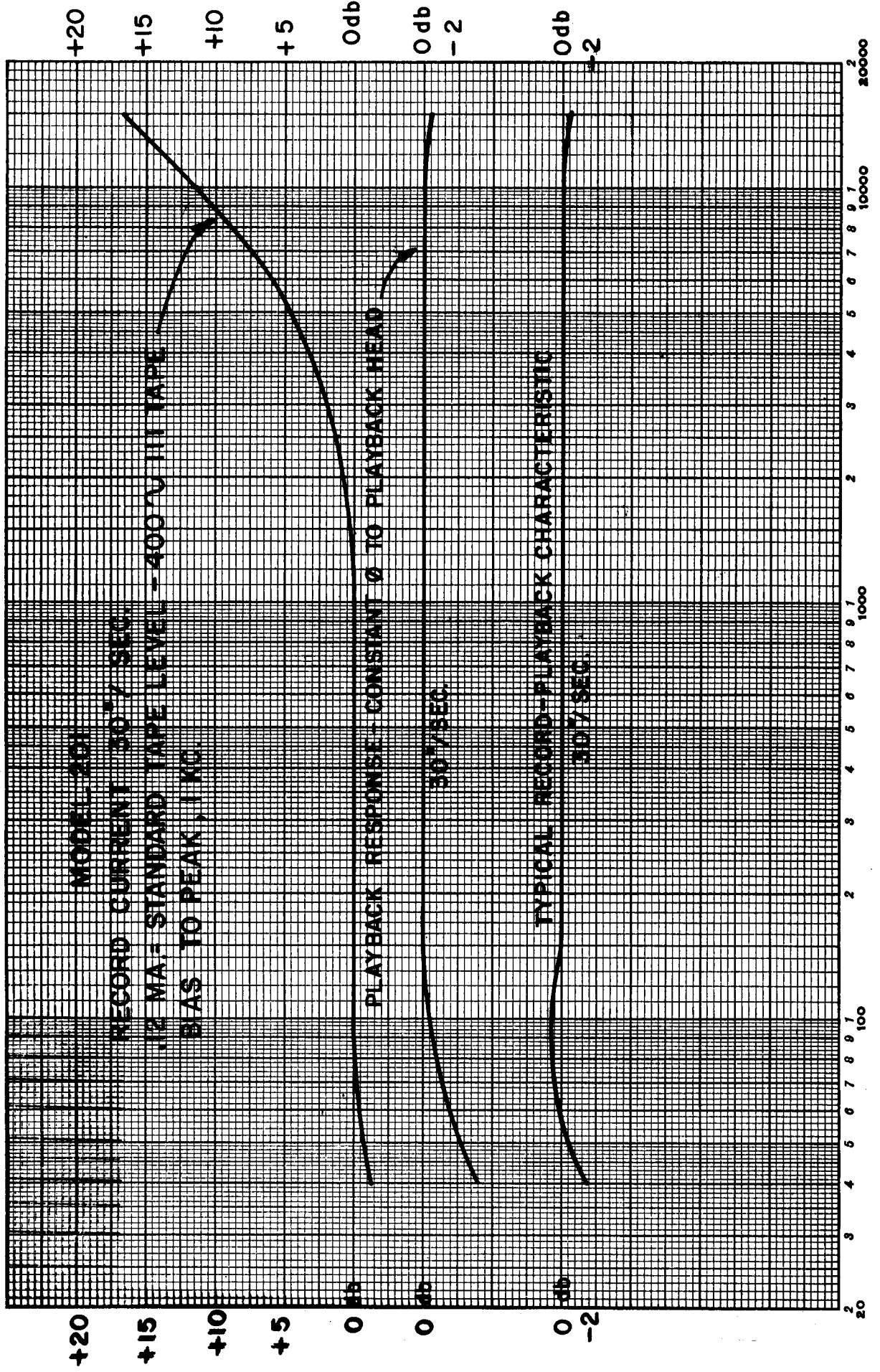

FREQUENCY IN CYCLES PER SECOND

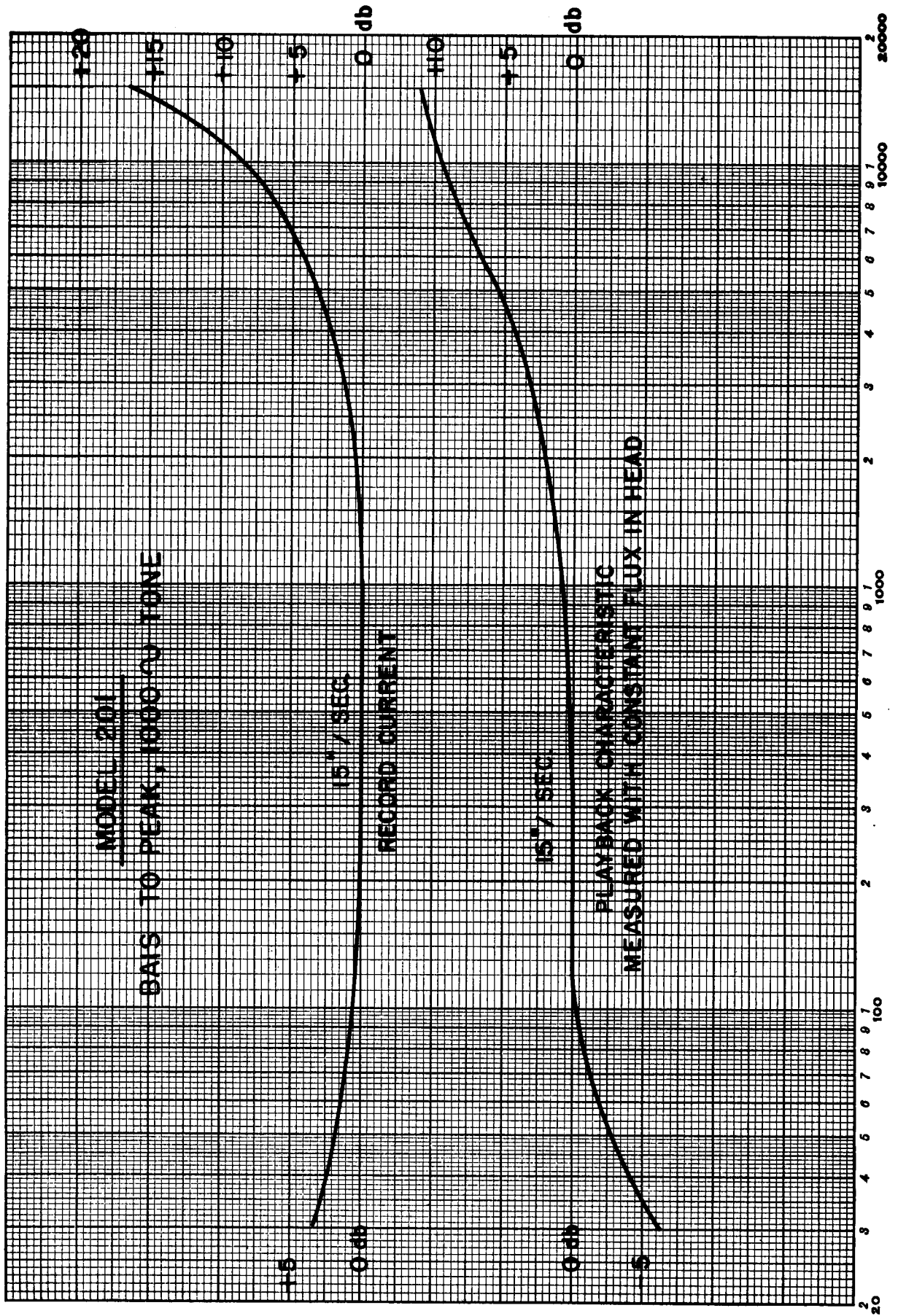

PLAYBACK OF OTHER MANUFACTURES STANDARD TAPES ON AMPEX MODELS 300, 301 & 201

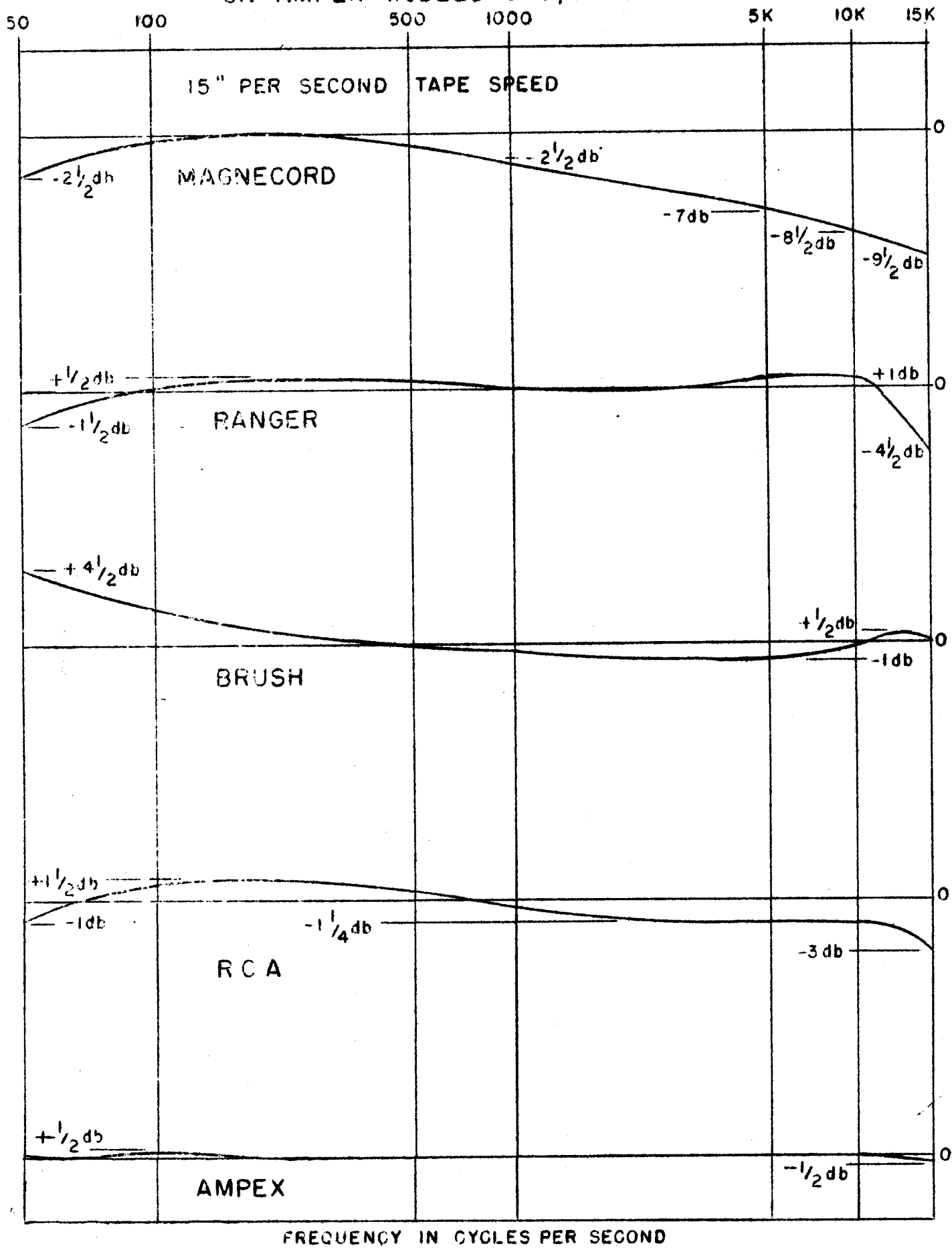

FREQUENCY IN CYCLES PER SECOND

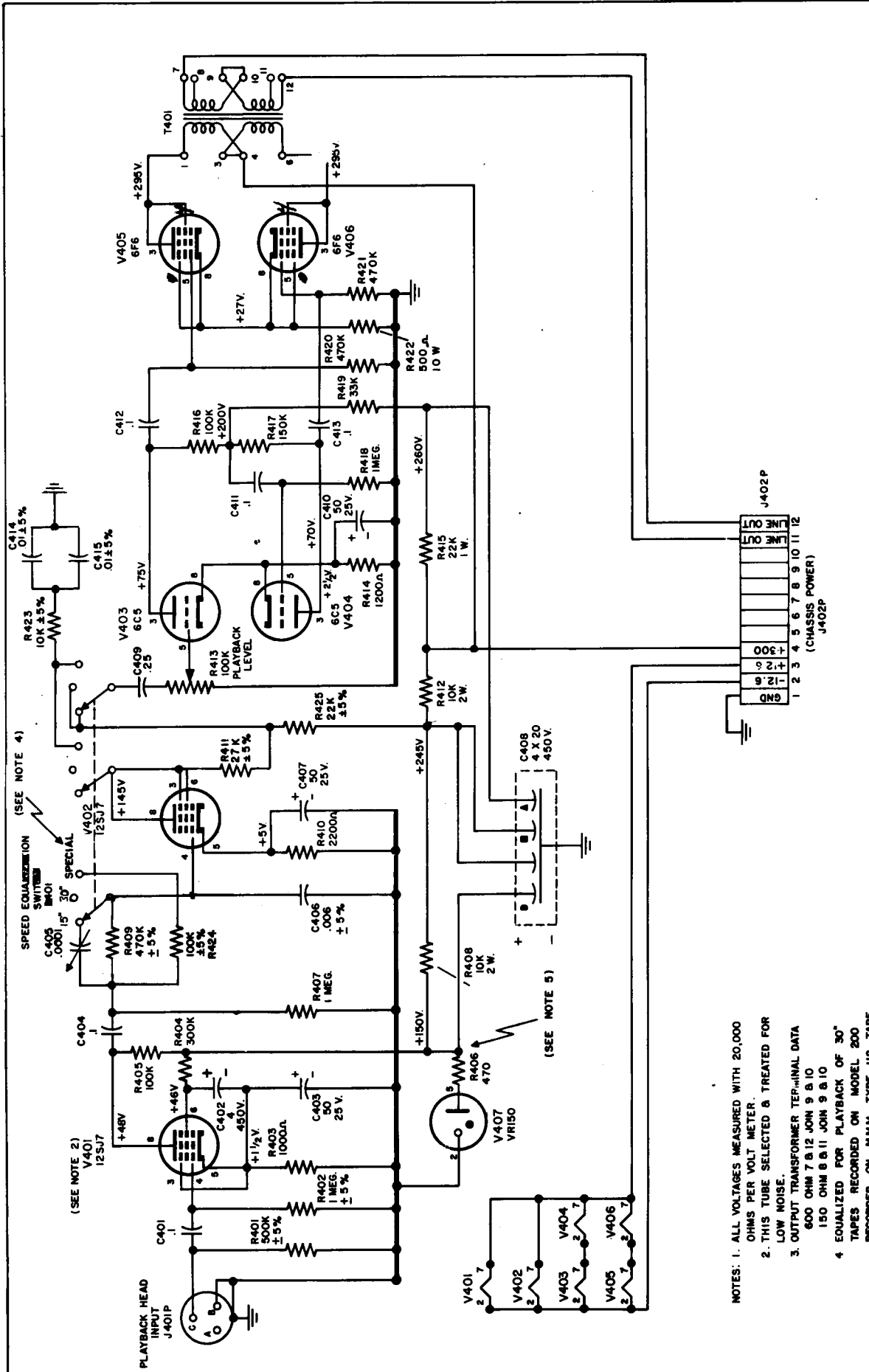

**PLAYBACK AMPLIFIER
MODEL 201**
AMPEX ELECTRIC CORPORATION
SAN CARLOS, CALIFORNIA

- NOTES: 1. ALL VOLTAGES MEASURED WITH 20,000 OHMS PER VOLT METER.
 2. THIS TUBE SELECTED & TREATED FOR LOW NOISE.
 3. OUTPUT TRANSFORMER TEF-MINAL DATA
 600 OHM 7 & 12 JOHN 9 & 10
 150 OHM 8 & 11 JOHN 9 & 10
 4. EQUALIZED FOR PLAYBACK OF 30" TAPES RECORDED ON MODEL 200 RECORDER ON MMM TYPE 112 TAPE
 5. MOTOR BOATING MAY OCCUR FOR APPROX. 30 SECONDS WHILE CONDENSER IS FORMING AFTER STANDING FOR LONG PERIODS.

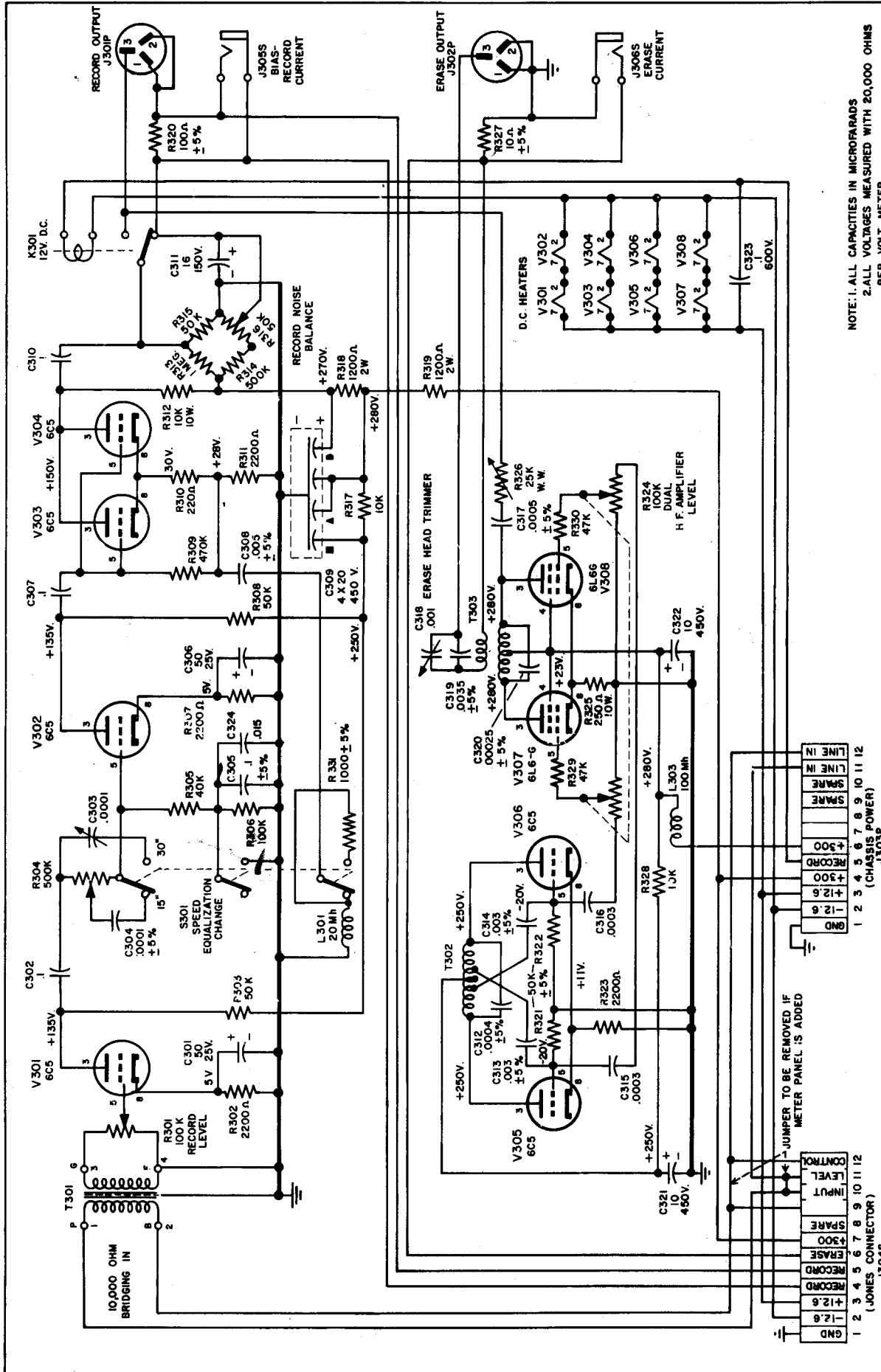

NOTE: 1. ALL CAPACITIES IN MICROFARADS
 2. ALL VOLTAGES MEASURED WITH 20,000 OHMS PER VOLT METER

**RECORD AMPLIFIER ERASE & BIAS SUPPLY
 MODEL 201
 AMPEX ELECTRIC CORPORATION
 SAN CARLOS, CALIFORNIA**

(CHASSIS POWER)
 J303P

LINE IN	1
LINE IN	2
SPARE	3
SPARE	4
SPARE	5
SPARE	6
+300	7
+200	8
+100	9
+50	10
+25	11
+12.5	12
GND	

JUMPER TO BE REMOVED IF METER PANEL IS ADDED
 (JONES CONNECTOR)
 J304S

CONTROL	1
LEVEL	2
INPUT	3
SPARE	4
SPARE	5
ERASE	6
RECORD	7
RECORD	8
+12.5	9
+2.5	10
+1.25	11
GND	12

METER CONTROL PANEL

