

Bose® 201 Direct/Reflecting™ Loudspeaker System

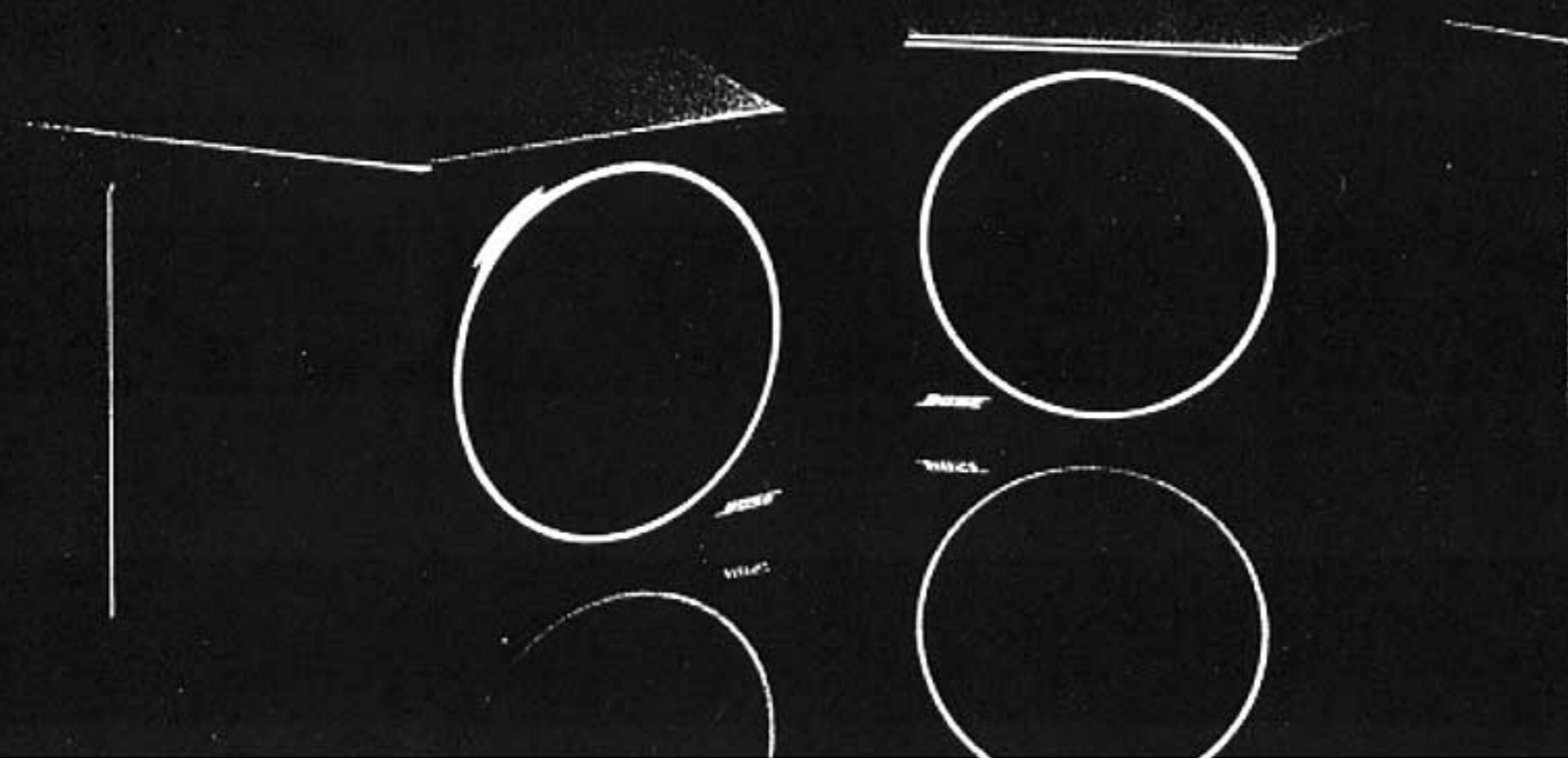

BOSE

The Bose® 201 Direct/Reflecting® Loudspeaker System

1. Introduction

Thank you for purchasing the Bose 201 Direct/Reflecting® Loudspeaker System. Its advanced design and quality construction will give you many years of listening pleasure.

The installation and operating principles of your 201 system are significantly different from those of conventional speaker systems. To obtain the best possible performance, **please take the time to read this manual.**

2. Unpacking

The shipping carton contains **two** 201 speakers labeled **Part 1** (left) and **Part 2** (right). Unpack each unit carefully, saving the carton and all packaging materials for later use.

If either speaker appears to be damaged when unpacking, **do not operate the damaged unit.** Repack both speakers in their original carton and notify your authorized Bose dealer immediately.

Do not attempt to remove the foam grille panels or "Bose" nameplates on your 201 Loudspeakers. This can result in damage not covered by the warranty.

3. Placement

201 Loudspeakers are designed for convenient placement in a wide variety of listening environments. They can be set on bookshelves and tables or flush-mounted directly onto a wall.

If you are placing your 201 speakers on a shelf or table, attach the self-adhesive rubber feet supplied in the shipping carton to the bottom of the speaker enclosures.

If you are wall-mounting your 201 speakers, obtain a set of **Bose 201 Wall Brackets** from your authorized Bose High Fidelity dealer. Complete instructions are included with the brackets.

The following placement guidelines will help you to realize the best possible performance from your 201 speakers in any type of installation. Refer to FIGURE 1.

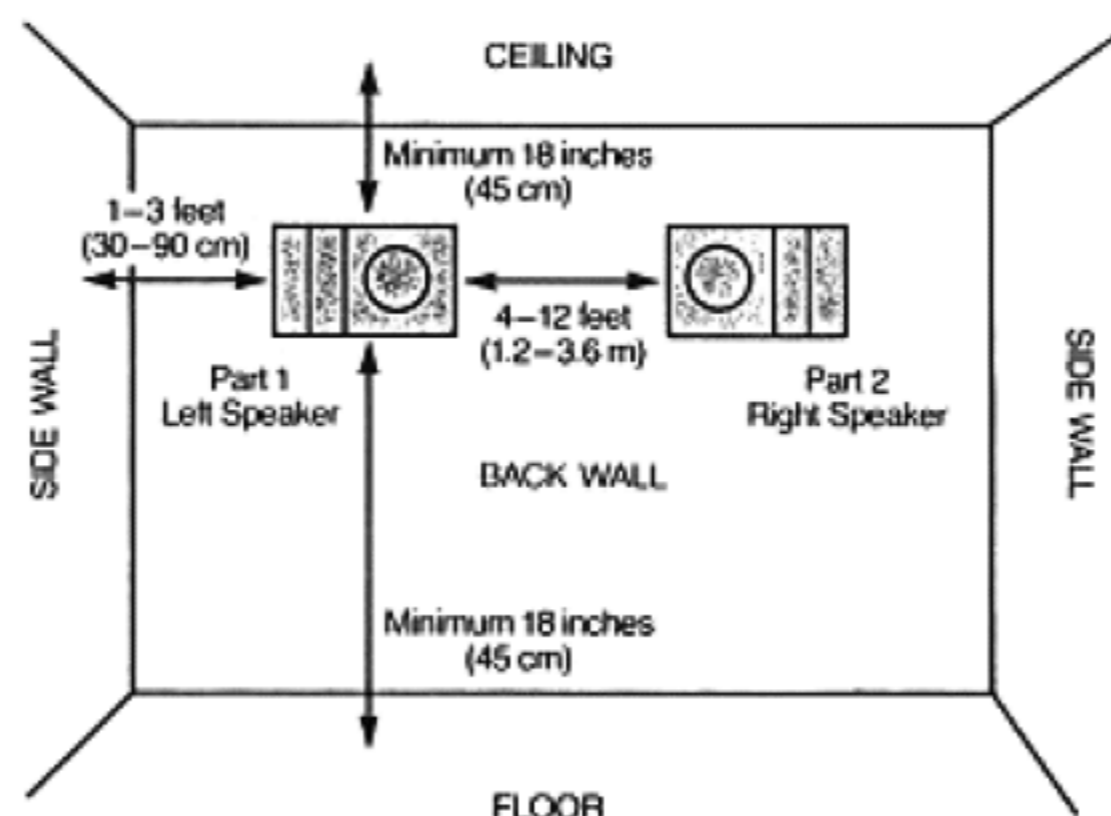

FIGURE 1. Recommended placement in average-sized listening rooms.

- Your 201 speakers work best when music is given space to develop "around" the cabinets, reflecting off nearby walls to create a wide, transparent stereo image. Hard materials such as wood, brick, glass, sheetrock and/or sturdy paneling generally provide the most effective sound-reflecting surfaces. Sound-absorbent furnishings (heavy drapes, etc.) should be kept away from the immediate vicinity of the speakers.
- Place the **Part 1** and **Part 2** speakers on the **left** and **right** sides of the room respectively, spaced 4-12 feet (1.2-3.6 m) apart. Vertical placement (with the energy controls facing directly upward or downward) is not recommended.
- Position the speakers **at least 12 inches** (30 cm) away from the side walls. Optimum distance is 1½-3 feet (45-90 cm).

- The most accurate bass response results when the speakers are set **less than 18 inches** (45 cm) away from the wall behind them, and **more than 18 inches** from the floor or ceiling. Avoid placing the speakers exactly halfway between the floor and ceiling.
- If your music seems to be lacking in deep bass, try moving the speakers closer to the wall behind them and/or nearer to the corners of the listening room. Heavy, "booming" bass can be tamed by moving the speakers away from corners and walls. You can also experiment with the tone controls on your amplifier or receiver to achieve a spectral balance that suits your listening environment and personal tastes.

4. Wire Selection

Audible coloration of the sound and/or power loss will occur if the wire connecting the speakers to your amplifier or receiver is too small. The table below specifies the **minimum** thickness of 2-conductor wire recommended for various speaker-to-amp distances.

RECOMMENDED WIRE SIZES*

Maximum Length	Wire Gauge
30 feet (9 m)	18 (0.75 mm ²)
45 feet (14 m)	16 (1.5 mm ²)
70 feet (21 m)	14 (2.0 mm ²)

*Based on a maximum frequency response deviation of ±0.5 dB.

Standard 2-conductor zipcord (available at electrical and hardware stores) can be used for speaker connection. This wire is often color-coded, or else has a ribbed line(s) running along one conductor for easy identification of the positive and negative leads.

5. Connection

Follow the next procedure to assure that both 201 speakers are properly connected to your music system. Refer to FIGURE 2.

- Turn off your amplifier or receiver and unplug it from the ac power mains before connecting the loudspeakers.
- Separate the conductors at the end of each length of wire. Strip approximately 1/2 inch (12 mm) of insulation off each conductor.
- Locate the input terminals on the back of the **left** speaker cabinet. Note that there are two terminals marked + (positive) and - (negative).
- Connect one wire conductor to the terminal marked - on the **left** speaker. Connect the other end of the **same** conductor to the output terminal marked COM, GND, NEG or - on the **left** channel of your amplifier. Use the color-coding or ribbed line(s) on the wire to be sure you are using the same conductor.
- In the same manner, connect the + terminal on the **left** speaker to the output terminal marked POS or + on the **left** amplifier channel. (If your amplifier offers a choice of output impedances, use the terminal marked 8 or 8 OHMS.)
- Repeat steps 4 and 5 above, connecting the **right** speaker to the **right** output channel of your amplifier. Tighten all terminal connections firmly.
- Check **very carefully** to be certain that no loose strands of wire are accidentally "bridged" across the terminals on either the speakers or the amplifier. **Bridged wires create short circuits which can damage your amplifier.** Repair any loose wire strands **before** operating your amplifier or receiver.

6. Phasing Test

If you are not certain that the speakers are connected to your amplifier "in phase" (i.e., positive to positive, negative to negative), perform this simple test:

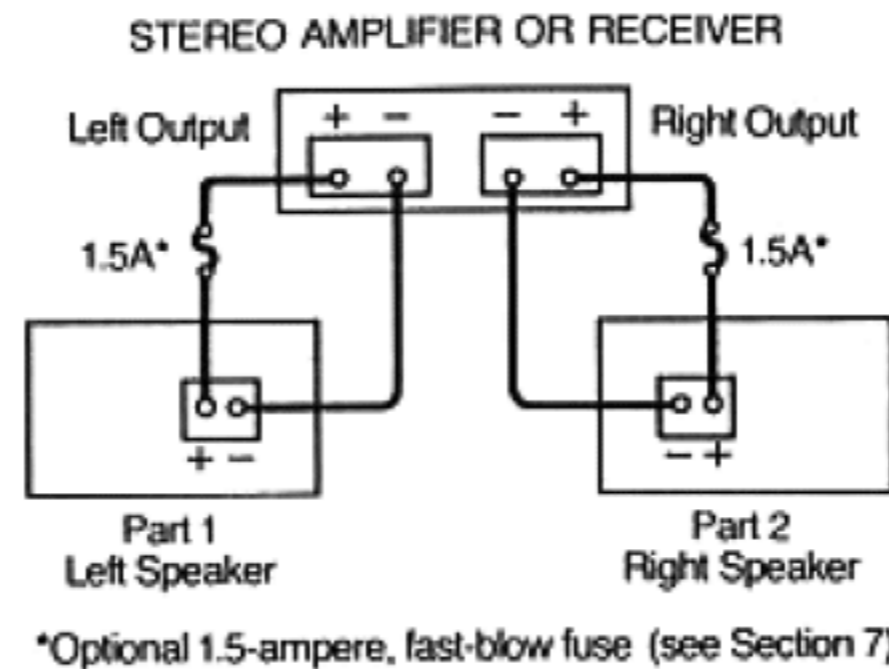

FIGURE 2. Speaker connection.

- Set your sound system for MONO (monophonic) reproduction. Be sure the balance control is centered or set to normal.
- Temporarily place the loudspeakers so that they are facing each other closely.
- Play music containing deep bass notes through the system. If the speakers are phased correctly, the sound will appear to come from a point between the speakers with full, natural bass response.
- If the music seems to be lacking in deep bass, reverse the + and - wire connections on **one** speaker and repeat the test. **Use the connection that produces the most powerful bass.**

7. Fusing

Any loudspeaker can be damaged if the amplifier driving it should fail. Damage may also occur by playing the music so loudly that it sounds distorted. **This can happen even with a low-powered amplifier or receiver.**

Your 201 speakers incorporate an automatic tweeter protection circuit which guards against certain types of electrical stress. Fusing will provide additional protection, and is recommended in most applications.

The fuseholders should be inserted into the + wire connecting each speaker to your amplifier or receiver (see FIGURE 2). Use **1.5-ampere, fast-blow** Buss AGC Series, Littelfuse 3AG Series or equivalent fuses.

A complete fuse kit including fuses and holders is available from the Bose Customer Service Department, The Mountain, Framingham, Massachusetts USA 01701 for \$5.00. Ask for the 201 Fuse Kit, Part Number 108938-4.

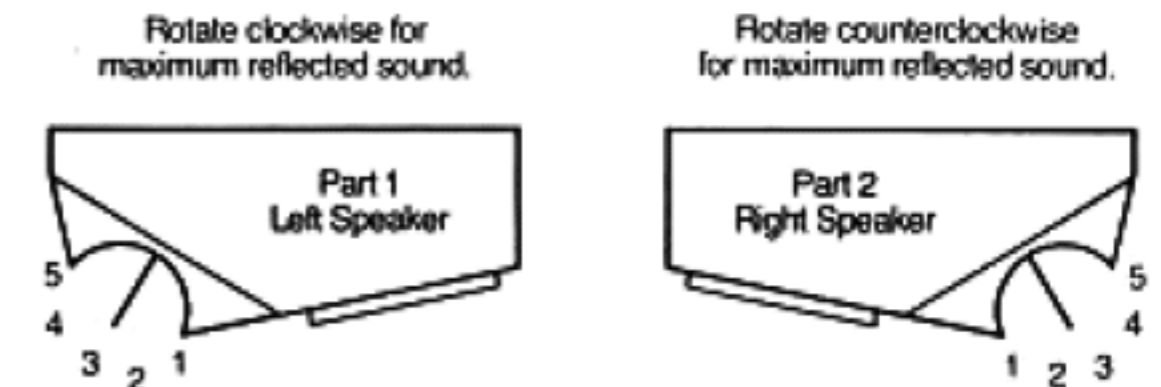

FIGURE 3. Operation of the Direct Energy Controls.

8. Direct Energy Control

The Direct Energy Control lets you change the balance of reflected and direct sound radiated by your 201 speakers to fit virtually any type of placement or music. Its audible effect depends on your distance from the speakers and the acoustics of your listening room. In most cases, proper adjustment of the Direct Energy Controls will significantly improve the performance of your 201 system.

Note that the numbers shown in FIGURE 3 are for reference purposes only and do **not** actually appear on the speakers.

Control positions 1 and 2 provide maximum **direct** sound energy at high frequencies. These positions should be used:

- if there is no sound-reflecting surface within 3 feet (90 cm) of the energy control;
- if the outer edge of the speaker is blocked because of placement limitations;
- for music in which a relatively concentrated stereo image is desirable (solo musicians, small ensembles).

Control position 3 provides a normal balance of reflected and direct sound energy. Use this position:

- when there is a sound-reflecting surface within 1–3 feet (30–90 cm) of the energy control;
- for music in which a normal stereo image is desirable (medium-sized performing groups, "studio" pop).

Control positions 4 and 5 provide maximum **reflected** sound energy at high frequencies. These positions should be used:

- only** if there is a sound-reflecting surface within 1–3 feet of the energy control;
- for music in which a wide stereo image is desirable (large-scale symphonic works, live concerts, electronic music).

These guidelines are based on experiments conducted in controlled acoustic environments and may not apply in every listening situation. Try various control settings on each speaker to achieve a spatial balance that satisfies your specific requirements. **It is not always necessary to adjust both Direct Energy Controls the same way.**

9. Maintenance

Your 201 speaker enclosures can be cleaned by wiping with a soft damp cloth and a mild detergent. The grille panels require no special care although they may be carefully vacuumed if necessary. All other maintenance should be referred to qualified service personnel.

10. In Case Of Difficulty

If you suspect a problem with your 201 speakers, use the following procedures to determine if the difficulty is actually in the speakers or in some other component of your music system.

If one speaker sounds less brilliant than the other, try adjusting the positions of **both** Direct Energy Controls in accordance with the recommendations in Section 8.

If one speaker sounds defective, do not switch the speaker cables, as this could damage a speaker. Disconnect the defective speaker at the amplifier output terminals and reconnect it to the amplifier channel that is operating correctly. If the speaker that sounded defective now plays properly, the problem is not in the speaker or wiring.

If trouble appears in both speakers, use the same wiring to connect them to another amplifier or receiver that is known to be working properly. If the speakers now operate correctly, the problem is not in the speakers or wiring.

If trouble persists in one or both speakers, contact your authorized Bose High Fidelity dealer. He will verify any defects and arrange for service by an authorized service agency or by the Bose factory. Bose Corporation will make every effort to remedy any problem within the terms of the warranty at minimum inconvenience to you.

11. Technical Information

Features

Asymmetrical Design
Direct Energy Control
Dual Frequency™ crossover network
Efficient ducted-port enclosure system
Automatic tweeter protection circuitry
Syncom® II computerized quality control

Driver Complement:

- One (1) 6-inch (15.2 cm) woofer
- One (1) 2-inch (5.1 cm) high-sensitivity tweeter

Nominal Impedance: 8 ohms

Crossover Transition Frequencies:

1.5 kHz and 2.5 kHz

Amplifier Power Requirements:

- 10 watts minimum
- 60 watts RMS maximum per speaker

Cabinet: High-density polystyrene

Dimensions: 7 $\frac{7}{8}$ " H x 14 $\frac{1}{8}$ " W x 6 $\frac{3}{4}$ " D
(20 x 36 x 17 cm)

Weight: 6.2 lbs (2.8 kg)

BOSE®

Better sound through research.

Bose Corporation, The Mountain,
Framingham, Massachusetts USA 01701

Australia, Belgium, Canada, England, France, Germany,
Greece, Ireland, Italy, Japan, Netherlands, Spain, Switzer-
land, United States