



# MONARCH RECORD CHANGER

.....

## Operating Instructions

THIS Recordchanger is designed to play all of the existing types of gramophone records in common use.

First there is the record that rotates at a speed of 78 revolutions per minute. This is the most common type and has been in use for many years. Generally this record is produced in two diameters 10" and 12", playing respectively about 3½ and 5 minutes per side. This Recordchanger will play a total of ten of these records at one loading, and the different diameters can be mixed—the machine will itself select the correct conditions for each diameter WITHOUT any adjustment. The only manual adjustment necessary is to turn the Pickup head to the 78 position and rotate the speed control knob to the 78 position.

Secondly, there is the new record which rotates at 33½ revolutions per minute. This is commonly called the LP or Long Playing type. It is produced in three diameters—12", 10" and 7". The playing time is much longer per side than with the old 78 r.p.m. type. Thus one side of the 12" diameter can play up to 20 minutes. Again this recordchanger will accept a mixed loading of three different diameters and will automatically select the correct conditions for each. Again the only manual adjustments are the Pickup head to the 33½ position and the speed change knob also to the 33½ position.

Thirdly, there is the record that rotates at 45 revolutions per minute. This is at present only produced in the 7" diameter size. Some of these records are sold with a large centre hole which must have an adaptor plate fitted to reduce the hole size to the common standard to fit the centre spindle. Three such adaptors are supplied with every Monarch Recordchanger. The more recent tendency is to sell 45 r.p.m. records with the standard small hole, allowing this centre to be pushed out when the large hole is required. With these records the speed must be set to the 45 position and the pickup set to the 33½ position.

### OPERATION

This Recordchanger will operate only on AC mains. Units are normally despatched from the factory connected for 200/250 volts unless otherwise requested. To change the voltage range refer to the VOLTAGE note and diagram.

**Loading.**—Lift the Record Control Arm by holding it at the far end (i.e. end furthest away from the Centre Spindle) and swing it clear of the Records. Then taking each record singly place it on the Centre Spindle resting the record on the spindle ledge. Hold this record in position with the left hand and load the others with the right hand in the same way. When all records are in position replace the Record Control Arm over the Centre Spindle. If the records are all of one diameter it may be more convenient to group the ten together, see that the centre holes are all in line and place the group on the Centre Spindle.

**Starting Up.**—Make sure that the pickup stylus is correct, that is either 78 or 33-45 and similarly the Speed Knob. The pickup is correctly set for 78 r.p.m. records when knob at the front of the pickup is so positioned that the numbers 78 (Std) are upright. To position the pickup for long playing records the number 33-45 (LP) must be upright. Then move the On/Off/Reject Knob to the left firmly but not too roughly. That is all that is required.

**Rejecting.**—To reject a record merely move the On/Off/Reject Knob to the LEFT.

When the last record is finished the machine will switch itself off automatically.

**TO REMOVE THE RECORDS.**—Swing the Record Control Arm out of the way. Grasp the records together and lift them gently from the Centre Spindle, easing them past the ledge on the spindle.

## OPERATING INSTRUCTIONS (continued)

### WHAT TO DO AND WHAT NOT TO DO.

1. Never force the Pickup Arm. This machine is robust but due to the featherweight action of the Pickup and the delicate balance required, any force will upset the adjustment.
2. When playing new records a certain amount of fluff will gather on the stylus point. This should be removed gently from time to time.
3. Always remember to use the correct stylus on the Pickup. If the wrong one is in use it may not be apparent from the music. However, the stylus itself may get somewhat damaged by continuous playing on the wrong point.
4. To play one record only it must be loaded on the Centre Spindle as described under 'loading.' It should not be placed on the Turntable. If it is placed on the Turntable the machine will switch itself off.
5. Before loading always see that the Magidisk Record Selector Arm (Item M103) is out and not stuck in a vertical position. In other words it must be BELOW the records.
6. Some very old 78 r.p.m. records have no "run in" grooves on the outside edge. Such records can be played but it will be necessary to move the Pickup inwards to the first grooves manually AFTER it has descended of its own accord. It will descend and stay stationary in most cases.

**THE PICKUP.**—This is of the crystal type and the pickup leads must be connected into the correct impedance. Thus a resistance of between  $\frac{1}{4}$  and 1 megohms is a suitable terminating impedance for the Pickup. It should be noted that an impedance of too high value will result in over accentuation of bass response.

No compensatory circuits should be used with this Pickup since it is designed to give the correct frequency response when loaded as above.

Should the pick up leads require extending a twin shielded extension is recommended the metallic shield being earthed. If however, the apparatus or receiver used in conjunction with the Recordchanger is of the AC/DC variety, a competent electrical engineer should be consulted to avoid the risk of mistakes in connection resulting in electric shock.

### USING THE 'MONARCH' CHANGER WITH RADIO RECEIVERS.

These notes apply equally to all Recordchangers and Gramomotors which use any type of Crystal Pickup. Crystal Pickups are capable of really high fidelity results but they must be used correctly. Unfortunately some Radio Receiver manufacturers have in the past, and some even now still do, consider only the old heavyweight type of magnetic pickup, and design the pickup, input circuits of their sets for this pickup only. Such receivers, as they stand are quite unsuitable for playing from the new Three Speed Motors and Changers. Even with the lightweight magnetic pickup good results cannot be obtained due to lack of receiver sensitivity.

However, our laboratories have tackled this problem energetically and have produced a Transformer which when used with the B.S.R. Crystal Pickup will give high quality results with practically all types of receivers.

If you find the music from your set thin and weak then almost certainly the input of your receiver is unsuitable for use with a Crystal Pickup. Your radio dealer can supply you with a B.S.R. Transformer which will correct this and give you the wonderful tonal quality for which the B.S.R. Pickups are justly famous.

**AC/DC Receivers.** We strongly advise the use of the B.S.R. Transformer when it is proposed to use the Monarch Changer with AC/DC Receivers. The input circuits of such receivers are connected to the electric mains, and the transformer isolates the Changer from the Mains, thus minimising the risk of electric shock.

**TECHNICAL NOTE.** Crystal Pickups being high impedance devices they must not be connected to impedances or resistances, below certain values. Generally it is wise not to allow such values to fall below 250,000 ohms. Some receivers have input circuits with resistances of 20,000 ohms, and lower. Such relatively low resistances can sometimes be removed and higher values substituted, but some technical knowledge is required here. The B.S.R. Transformer MATCHES such low values to the high impedance of the Crystal Pickup.

Transformer Type AF 333 should be used with the 'Monarch' Changer.

### WHEN PURCHASING RECORDS FOR USE ON RECORDCHANGERS

Great care must be taken to satisfy yourself that the records you are about to buy are FLAT. Many records on sale are 'Dished.' These if used on a Recordchanger will almost certainly cause record slip, resulting in extreme 'wow' or variation of pitch. Sometimes the record will come to a standstill while the Turntable is revolving. If you place the straight edge of a rule along the record its flatness will at once be evident.

### LONGPLAYING RECORDS.

In addition to playing for a longer time than the 78 r.p.m. record the LP's give a background free from scratch. This results in itself in a greater degree of realism. However, these records are very prone to gather dust. The dust causes crackles in the reproduction not unlike 'atmospherics.' While a moist clean cloth may be used to clean the surfaces it is better to keep the dust away in the first place.

Longplaying records have a surface—up to the present—which is more delicate than the older 78 r.p.m. type. Take great care not to put them down on a dusty surface, or to leave them lying about exposed. The surface is easily scratched.

# 'MONARCH' RECORD CHANGER

## ADJUSTMENTS

**Needle set down.** The set down position of the needle on the record is adjusted by manipulation of the needle adjusting screw. (Item M244). (See Dia. 'A'). Adjust this screw until the correct set down of the needle on a 10" record is obtained. The correct position is  $\frac{1}{8}$ " from the edge of the record. It is advisable to make this adjustment with a stack of 10" records on the turntable. When correctly positioned for a 10" record, the 12" and 7" needle set down will also be correct.

**Pick-up Arm Height.** The pickup arm height is adjusted by the pickup height adjusting screw (Item M249). (See Dia. 'A'). To raise the height of the pickup arm turn this screw counter clockwise. To lower the pickup arm turn clockwise. The pickup height should be adjusted so that with a 1" stack of records on the turntable, the point of the needle clears the top record by  $\frac{1}{16}$ ". A check should then be made to ensure that the pickup arm clears the underside of records loaded on the centre spindle.

**Needle Pressure.** The needle pressure should be 12 grams. Adjustments may be made to weight by repositioning the pickup balance spring (Item 245) in the various adjusting holes provided (see Dia. 'A') until the correct pressure is obtained.

**Adjusting of Speed Change.**

- (1) Set the three speed knob at the 45 r.p.m. position.
- (2) Ensure that the three speed slide (Item 217) is engaged on the centre step of the 3-speed lever (Item M222).
- (3) Slacken grub screws on the 3-speed pulley (Item 234) and adjust until the jockey pulley (Item 202) is engaged mid-way on the centre step but clear of the pulley cam. (See Dia. 'B').
- (4) Tighten grub screws.

## PLEASE NOTE

No oil should be used on the Trip Arm Bearing (see Dia. 'C').

The 'Monarch' is normally despatched from the factory for operation on 200-250 volt 50 cycles mains supply.

If it is to be operated on a mains supply at 100 to 125 volt cycles the connection leads from the motor to the Switch Box and from the switch to the mains supply should be rearranged in accordance with the schematic diagram alongside.

If the 'Monarch' is required for operation on 60 cycles mains a special three-speed pulley is needed.

Units for 60 cycles mains can be supplied on request.

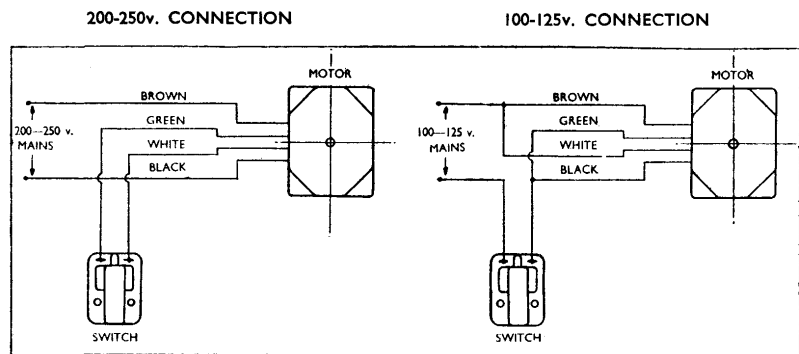

## LUBRICATION

A periodic check should be made to ensure that your Changer is lubricated adequately at the points detailed below :—

**Heavy grease should be used on the following points—**

- (a) Main Slide (Item M.126), grease faces rubbed by cam (Item M.131), and also end of tongue.
- (b) Actuating Lever (Item M.116), grease inside face of pawl resetting strip.
- (c) Reset Arm (Item M.169), grease portion that rubs on Cam Gear (Item M.124).
- (d) Main Sub-plate (Item M.123), grease guide slots.
- (e) Ballrace (Item M.28), fill ballrace cup with grease and assemble with open end upwards.
- (f) Three-speed Pawl (Item M.223), grease nose of pawl.
- (g) Three-speed Lever (Item M.222), grease rising step faces which bear on slide (Item M.217).

**Light Oil should be used on the following points—**

- (a) Control Spindle (Item M.4), oil spindle.
- (b) T.T. Bearing (Items M.24 and M.26).
- (c) Rivet (Item M.99), oil sparingly taking care not to drip oil down on to plastic Selector Arm Bearing (Item M.102).
- (d) Rivet (Item M.81).
- (e) Jockey Pulley Bearing (Item M.203)
- (f) Push Rod (Item M.227).

## DISMANTLING

(1) **Turntable Assembly (Item M23A).**

Remove circlip (Item M74) and lift the turntable vertically upwards over the centre spindle. Take care not to lose the thin thrust washer (that sticks to underside of turntable boss), ballrace or second thrust washer. *Note* : Before replacing assembly, set speed knob to 45 r.p.m. This allows easy manoeuvrability of jockey pulley when replacing turntable, without possible danger of bending jockey arm.

(2) **To remove Control Arm Assembly (Item M2A). (See Dia. 'C').**

Remove circlip (Item M5) on underside of control arm spindle (Item M4). (See Dia. 'G').

(3) **Pickup Arm Assembly.**

This must be done after the Changer has switched itself off. Unsolder the pickup leads from the connecting tagstrip. Unscrew the pickup top bearing (see Dia. 'A') and then lift the pickup arm clear. Replace the pickup top bearing to avoid losing the spacer washer.

(4) **Main Sub-Assembly.**

Remove turntable and pickup arm as described and 3 screws (Items M79, M80 and M155) holding sub unit. Main sub-assembly can then be gently removed from unit-plate.

(5) **B.S.R. TC4 Cartridge. (Dia. 'H'). (From Pickup Arm).**

Turn cartridge round with knob so that 10BA bolt can be unscrewed. Slide out knob. Cartridge should then gently be eased out of its cradle by pressing down against spring at rear. Both spring and pivot are then loose. Slide back the short length of 4 mm. PVC sleeving and pull out the two socket tags. (See Dia. 'H').

(6) **HGP. 37 Cartridge. (Dia. 'I'). (From P.U. Arm).**

Unscrew the two self tapping screws securing the cartridge bracket to the arm moulding. Ease the two pickup lead tags from the lugs at the rear of the cartridge case.

(7) **Needle (Stylus). (From B.S.R. TC. 4 Cartridge).**

Take hold of stylus arm and with a strong pair of tweezers pull stylus out at an angle of 25° to centre line of cartridge body. The replacement needle should be eased into the needle housing until positioned identically to the needle on the reverse side of the cartridge. (See Dia. 'H'). Great care should be taken when replacing the needle, as undue pressure might easily permanently damage the pickup.

(8) **Needle (Stylus.) (From HGP.37 Cartridge).**

Grip the stylus point between thumb and finger and pull in an arc over the cartridge (see Dia. 'I'). The new stylus may be fitted in the reverse manner but care should be taken to ensure that the stylus arm is sitting down in the front pocket.



MANUFACTURED BY

**BIRMINGHAM SOUND REPRODUCERS LTD.**

**MONARCH WORKS, OLD HILL, STAFFS., ENGLAND**

TELEGRAMS : "ELECTRONIC CRADLEY HEATH"

TELEPHONE : CRADLEY HEATH 69272/3/4

# 'MONARCH' RECORD CHANGER

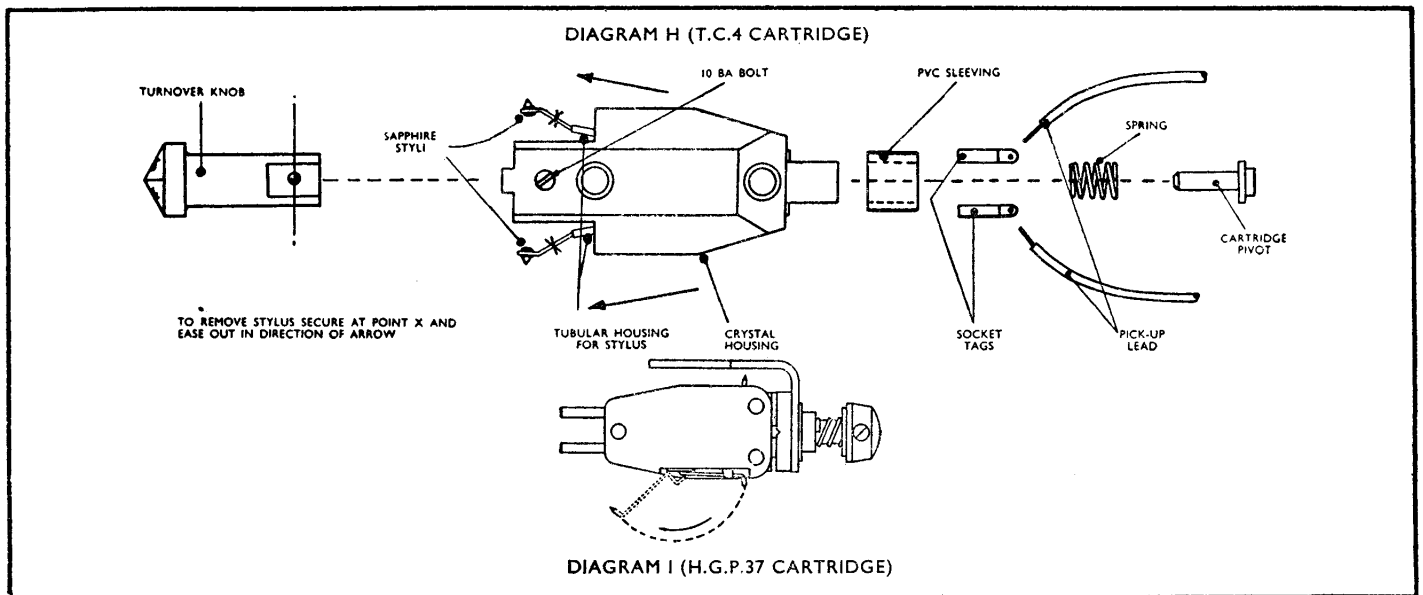
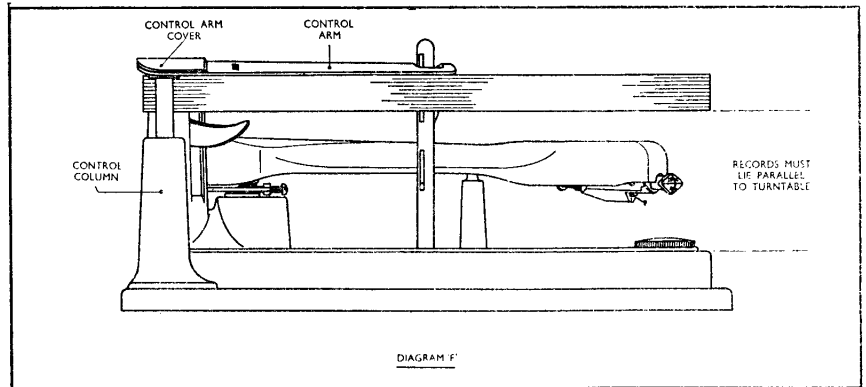
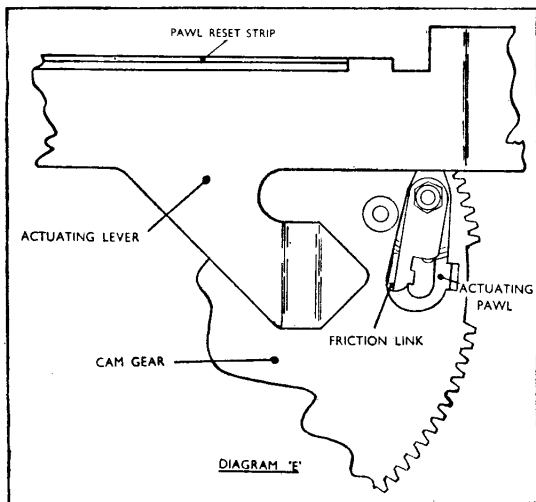
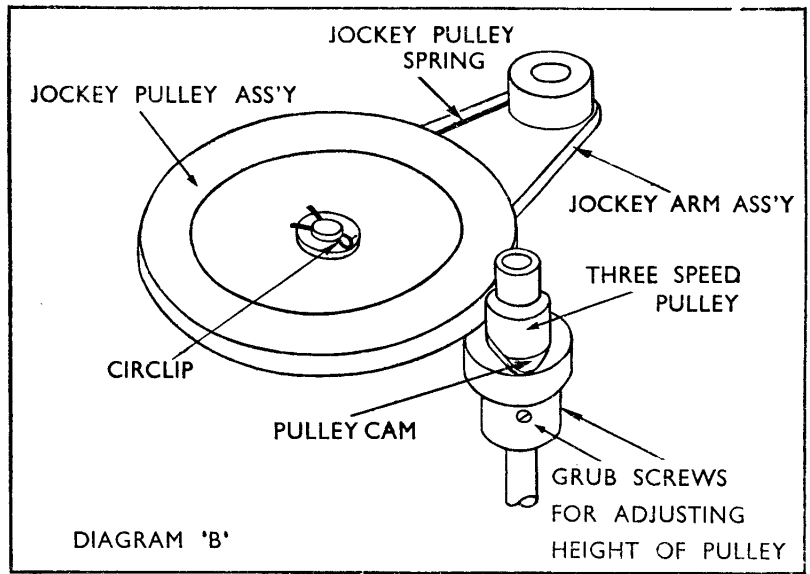
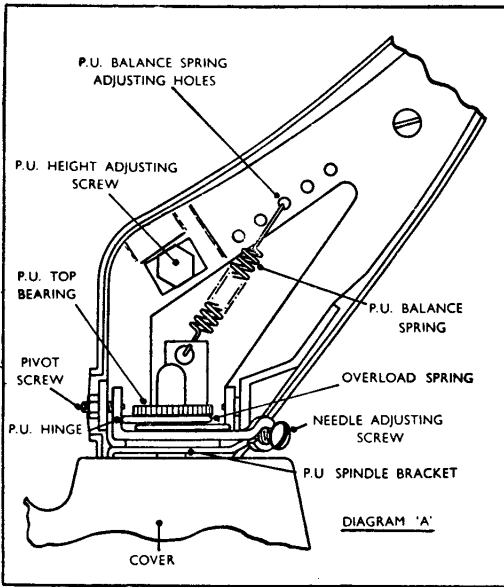

# NGER — ADJUSTMENTS

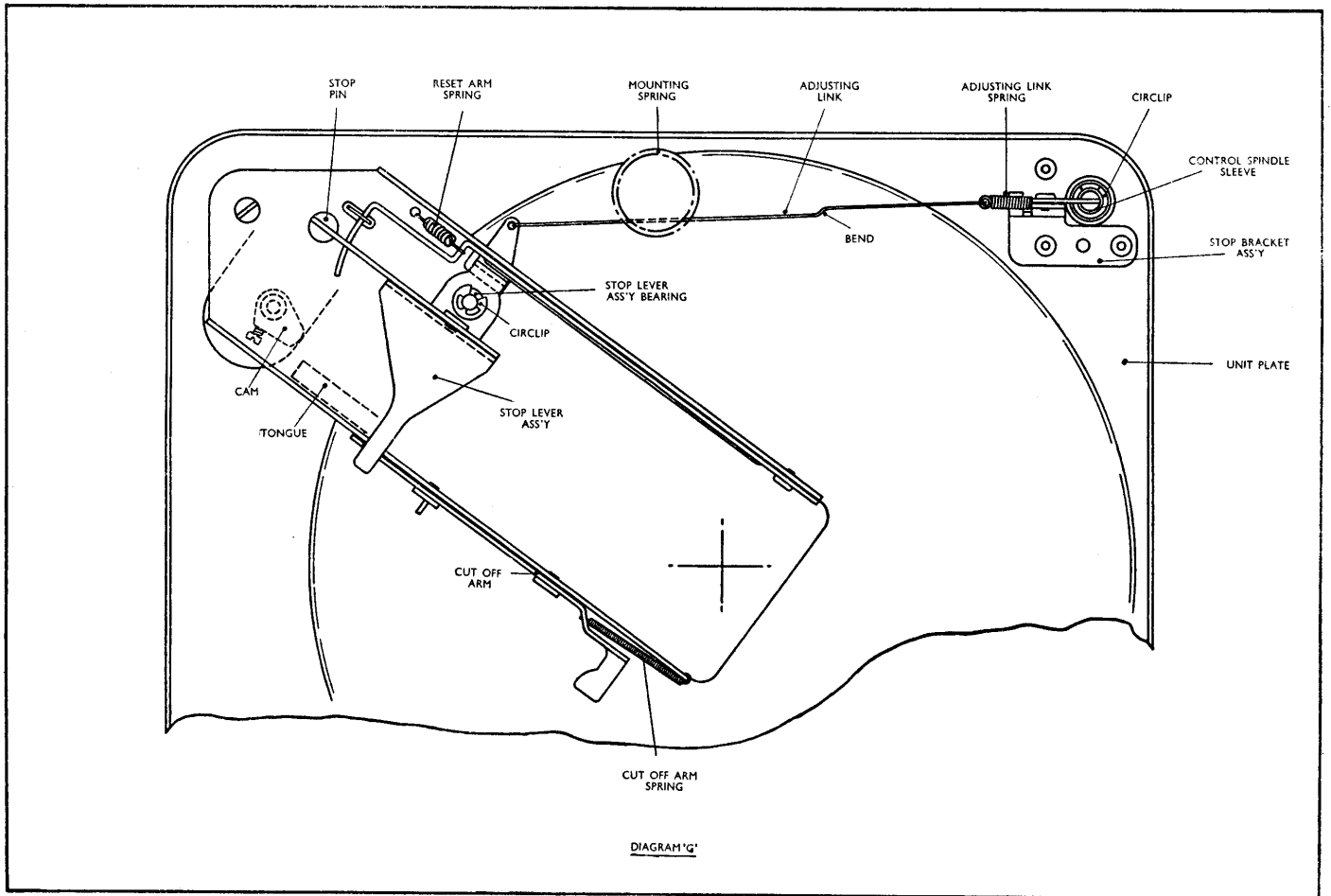
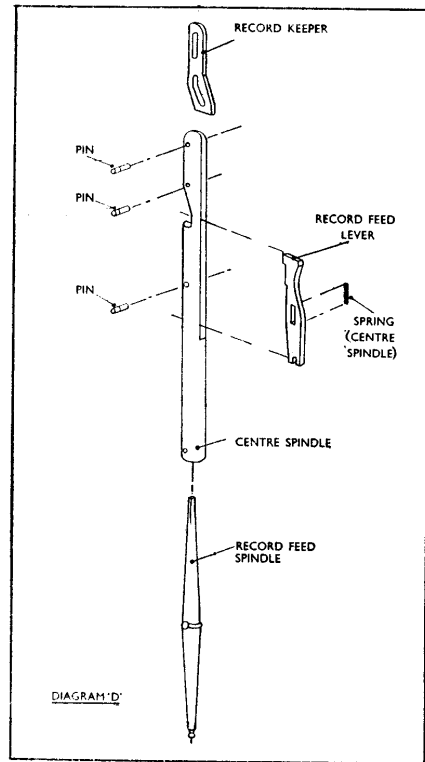
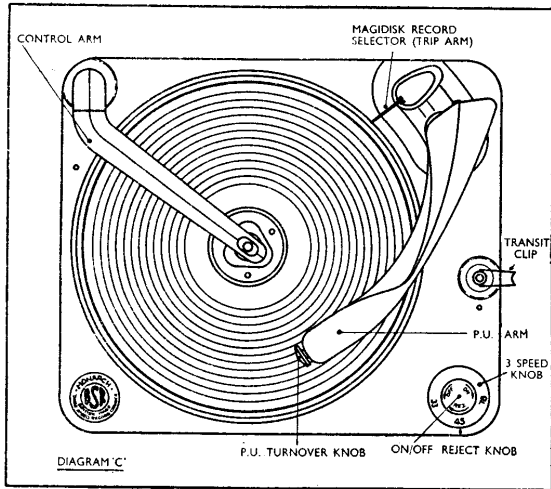

SYMPTOMS.	CAUSE.	REMEDY.
I. Turntable does not rotate when On/Off reject knob is turned to 'ON.'	(1) No current to motor.  (2) Motor Defective.  (3) Jockey Pulley not engaging Turntable rim.	(a) Check that current has reached external mains lead. (b) Check that switch box assembly is functioning correctly. (c) Check all wiring and solder terminals to and from the switch box assembly. (a) Remove the turntable and allow the motor to operate without load. If motor spindle is not rotating and mains supply is reaching the motor, the motor is faulty. Repair or replace. (b) Check that the 3-speed pulley (Dia. 'B') is not loose on motor spindle. If loose adjust as under "Adjustments of Speed Change." (a) Check that the jockey pulley is free to move on its slide. (b) Check that the jockey pulley spring is correctly positioned and functioning (see Dia. 'B') that is pushing pulley to fully outwards position. (c) Carefully clean the inside rim of turntable and rubber tyre on jockey pulley to ensure that they are free from oil and grit. Ensure that the On/Off Reject knob is turned to its fullest extremity in the 'ON' direction.
II. Turntable revolves when On/Off reject knob is turned to 'ON' but pickup remains stationary on its rest.	(1) Incorrect manipulation of control.	Ensure that the On/Off Reject knob is turned to its fullest extremity in the 'ON' direction.
III. Pickup lifts but fails to move in when record drops. The pickup returns to rest and the turntable continues to revolve	(1) Stop Pin (Item M164) (see Dia. 'G') not dropping freely. (2) Stop plate does not clear stop pin to allow it to fall.  (3) Adjusting link (Item M187) too tight (see Dia. 'G'). (4) Stiffness in Stop bracket assembly bearing (see Dia. 'G').	Remove all grease, oil, grit, burrs or rust carefully from the stop pin and spring (Item M166) and ensure that spring is not damaged. Bend tongue (marked on Dia. 'G') slightly inwards until when slide (Item M126) is at full extent of its movement forward it moves stop plate (Item M150) away from stop pin sufficiently to allow stop pin to drop. Slacken adjusting link by decreasing bend. Free and lightly oil.
IV. Pickup lifts but fails to move in when record drops. Pickup returns to rest and changer switches off.	(1) Cut off arm (Item M191) (see Dia. 'G') not returning to neutral position.  (2) Undue friction at Stop lever assembly bearing (see Dia. 'G'). (3) Stiffness in Stop bracket assembly bearing (see Dia. 'G').	(a) Cut off arm spring (Item M190) (see Dia. 'G') damaged. Replace. (b) Friction on moving surfaces of cut off arm. This lever must be absolutely free to slide in its slots. Check for rust, frays in slots, etc. Remove, clean and lightly oil. Free and lightly oil.
V. Pickup arm strikes record on spindle when it rises or needle catches on last record when it moves out.	(1) Pickup arm height not adjusted properly. (2) Control arm (Item M2) not holding records level. (3) Needle bent in crystal cartridge	See instructions for "Adjusting Pickup Arm Height" under 'Adjustment.' Hold control column securely and twist control arm until it will hold record stack parallel to top of turntable (see Dia. 'F'). Replace needle. (See necessary instructions under 'Dismantling.')
VI. Turntable speed too slow.	(1) Tightness in motor bearing. (2) Binding in turntable bearing.  (3) Jockey Pulley Slip.  (4) Undersized 3-speed pulley.  (5) Mains voltage too low.  (6) Operating temperature too low.	Tap lightly the side of motor laminations to free self aligning bearings. Check turntable bearing for freedom. If it does not turn easily when disengaged from the jockey pulley assy. (Item M234A) remove turntable, clean off foreign matter and lubricate with light mineral oil. Remove turntable and clean rim of jockey pulley. Oil jockey pulley slide and make sure that pulley slides freely. Remove any trace of oil on jockey pulley rubber or inside of turntable rim. Remove turntable and fit new 3-speed pulley. Pulleys are available as follows : Small—Red Pulley; Medium—Green Pulley; Large—Blue Pulley. To increase turntable speed remove existing pulley from the motor shaft and fit the next size larger, or vice versa to reduce speed. When fitting new 3-speed pulley see "Adjustments of Speed Change" under 'Adjustments.' The mains voltage should be not less than 200 volts when the unit is wired for 200-250 volts, or 100 volts when wired for 100-125 volts. If the machine has been standing in a cold place or operated in surroundings at a temperature of less than 45°F. the turntable speed may be too slow initially. Replace 3-speed pulley as instructed at '4' under "Turntable Speed too Slow."
VII. Turntable speed too fast.	Oversize 3-speed pulley.	Replace 3-speed pulley as instructed at '4' under "Turntable Speed too Slow."
VIII. Changer continues to cycle. With pickup dropping on to record during every cycle.	(1) Pawl reset strip (see Dia. 'E') distorted.  (2) Actuating Pawl and friction link assembly (see Dia. 'E') too free.	Make sure that this strip is straight and resets friction link (Item M118) and actuating pawl (Item M120) by engaging with friction link shoulder during cycle (see Dia. 'E'). Damp down the bearings of this assembly by smearing with medium grease.
IX. Noise during playing of record.	(1) Motor rumble.  (2) Defective turntable bearing.  (3) Defective jockey pulley.  (4) Defective records.	(a) If a low pitched rumbling sound comes from the loudspeaker while the record is being played, check the motor rubber mountings to be sure the motor is freely suspended on them. The motor lead wires should have slack to allow the motor to float. (b) Check that cam (Item M143) (see Dia. 'G') is pressed against the unit plate, and that securing screw is tight. Check for foreign matter in the bearings, defective balls, binding between balls, ball cage and thrust washers. Grease ball race and washers. Lubricate with light mineral oil. A rapid thumping sound while the motor is running may indicate a flat on the motor jockey pulley (Item M202) (Dia. 'B'). If this condition has not cleared up after 10 minutes of running time, remove the turntable and check the rubber tyre on the jockey pulley. If the surface is not smooth, replace the jockey pulley. Should the bearings or the slides of the jockey assembly show signs of excessive wear, replace the jockey unit assembly. Worn or defective records cause needle scratch and distortion of the recorded sound. If the record is warped it may slip on the other records causing 'wow.' An enlarged hole in the record can also cause 'wow.'

# E C H A R T

SYMPTOMS.	CAUSE.	REMEDY.
	(5) Squeaks.	Squeaking sounds as the changer operates indicates a lack of oil. Lubricate.
X. Distortion of recorded sound.	(1) Defective record. (2) Defective amplifier. (3) Bad cartridge.	(See '4' under "Noise during playing of record"). Check both amplifier and speaker.
XI. No sound during playing.	(4) Dust on needle. (1) Defective cartridge. (2) Defective wiring. (3) Defective amplifier.	Replace. (See instructions under 'Dismantling.') Brush off dust with finger. Replace. (See instructions under 'Dismantling.') Check pickup leads for short or open lead. Check amplifier and speaker.
XII. Changer does not shut off after last record has been played, possibly continuing to play the last record from the 7" position.	(4) Loose cartridge socket tags. (1) Control arm (Item M2) (Dia. 'F') binding. (2) Adjusting link (Item M187) broken, disconnected or too slack (see Dia. 'G'). (3) Adjusting link spring (Item M12) loose, broken or faulty (see Dia. 'G'). (4) Undue friction at stop lever assembly bearing (see Dia. 'G').	Remove, tighten slightly and replace. The record control arm must drop below the offset shoulder of the centre spindle or the changer will not shut off. Replace or repair. } Tighten adjusting link by increasing bend. Replace or repair. }
XIII. Changer returns pickup to rest before all records have been dropped. Turntable continues to revolve or changer switches itself completely off.	Adjusting link (Item M187) too tight (see Dia. 'G').	Remove, clean and lightly oil. Slacken adjusting link by decreasing bend (see Dia. 'G').
XIV. 3-speed knob (Dia. 'C') does not select 33, 45 or 78 when registering that speed.	Speed change wrongly adjusted.	Refer to "Adjustments of Speed Change" under 'Adjustments.'
XV. Record does not drop when changer cycles.	(1) Record feed spindle (Item M72) (Dia. 'D') broken. (2) Record feed lever (Item M69) (Dia. 'D') broken.	Replace record feed spindle or complete centre spindle. Replace record feed lever or the complete centre spindle.
XVI. Two records drop at once.	(1) Hole in record too large. (2) Record keeper (Item M65) (Dia. 'D') not fully down. (3) The record control arm (Item M2) not holding records level.	Replace record. Carefully clean and remove burrs. Do not oil. It should fall under its own weight. Refer to Dia. 'F.' Hold control column securely and twist control arm until it will hold record stack parallel to top face of turntable.
XVII. Needle does not set down on 7", 10" and 12" records in proper position.	(1) Pickup arm not adjusted properly. (2) Needle bent.	See "Needle set down" under 'Adjustments.' Replace with new needle. (See necessary instructions under 'Dismantling').
XVIII. Pickup remains on record run-out groove, or on last groove.	(1) No finishing run out groove on record. (2) Needle jumps out of groove in record. (3) Faulty Actuating Pawl and Friction Link (see Dia. 'E').	Check record for eccentric run out groove in centre of record. Some old records and home recordings do not have this eccentric run out groove. (a) Check that needle pressure is correct as under 'Adjustments.' (b) Check that the record is not defective—the run out groove is often too shallow. (c) The needle point might be damaged or affected by excessive accumulation of dust. Replace or clean. (d) There may be binding in the pickup spindle bracket (Item M147 and Items M146 and M136). Ensure that all moving parts are free and lightly oiled. When friction link has been moved towards centre of gear wheel and then slowly pushed outwards it should also carry the Actuating Pawl outwards from the start of its movement. If the Pawl does not move freely with the link it will not engage the turntable boss to start cycle. Dismantle Link and Pawl, clean, reassemble and oil. Care with tiny spring, between the two parts.
XIX. Pickup does not move in when set down on record.	No run in groove on record.	Check that the record is of the standard type which has a run in groove from the outside edge of the record to the recorded section. Some old type records and home recordings do not have this run in groove. (a) Clean the foreign material from around the needle. (b) Check needle to see if the tip is broken or bent and replace if necessary. (To replace see necessary instructions under 'Dismantling').
XX. Needle does not track across record properly.	(1) Needle may be clogged with an accumulation of dust or be worn. (2) Pickup leads too tight. (3) Changer not level. (4) Binding or friction in the pickup spindle bracket assembly. (Dia. 'A'). (5) Pickup arm not free to ride up and down on pickup hinge. (Dia. 'A'). (6) Needle pressure insufficient. (7) Actuating Lever (Item M116) (Dia. 'E') not free on slide. (8) Pickup hinge fouling pickup cover (Dia. 'A'). (9) Worn records or records with damaged groove. (10) P.U. spindle bracket (Item M147) fouling tongue on stop plate (M150) in down position of P.U. spindle bracket.	Give the pickup leads enough slack to allow the tone arm to move freely across the record. Ensure that the changer is level before use. Ensure that all moving parts and bearing surfaces in this assembly are free and lightly oiled. Adjust pivot screw until pickup arm is absolutely free to ride up and down. Tighten nut and CHECK AGAIN. Check as under 'Adjustments.' This lever must be absolutely free to slide in slots. Check for bending, rust, frays in slots, etc. Bend hinge up to clear. Replace record. (a) Clear dirt. (b) Bend tongue to clear.