

## BSR MONARCH MULTI-SPEED AUTO CHANGER

Price £16 10s. 3d. (£12 10s. plus £4 0s. 3d. tax); date released, March 1953.

The Monarch will play up to eight mixed 10 and 12in. standard 78 rpm records, ten mixed 33½ rpm records, or ten 7in. The changer has a minimum of moving parts. Easy record loading and foolproof speed change and on-off-reject controls—two in all—are provided. The lightweight rotary crystal pickup head incorporates sapphire styli which can be easily replaced by retailer or user. For 110-120V and 200-250V, 50c/s AC. Manufactured by Birmingham Sound Reproducers Ltd., Clarendon Works, Clarendon Street, Old Hill, Staffs.

OF MODERN styling and finished in hammered bronze or cream, the Monarch auto-changer is completely self-contained (Fig. 1). Assembled on a pressed steel baseplate, it requires a minimum cabinet fitting space: 12½in. wide, 10½in. deep, with 5½in. clearance above and 3in. below. The baseplate is fitted with four suspension springs to eliminate acoustic feedback. Pickup arm and base, control knobs and selector cover are of Bakelite; all moving parts of changer mechanism are chemically blacked.

Output from the crystal pickup is .75V at 1,000 c/s, with a frequency range of ±3dB from 25-10,000 c/s when loaded at 2 megohms. Therefore with this loading no compensatory circuits are required. The output should be fed into an impedance of not less than 1 megohm, otherwise the lower frequencies will suffer. The crystal has one sapphire stylus for 78 rpm records and another for use with 33½-45 rpm discs. An engraved rotary knob on the front of pickup head enables the user to easily change from one to the other without error. STD on the knob represents stylus for 78 rpm records, while LP indicates 33½-45 rpm.

Mains voltage adjustment is by means of two shorting links in the Bakelite on/off switch housing on underside of unit (Fig. 3). The correct positioning of the links is shown on the moulded cover, secured by two screws.

To operate the changer, place one or more records of the same speed on the loading spindle (Fig. 2), put slot on control arm (Fig. 2) over spindle, adjust speed control knob, turn engraved knob on pickup head so that the letters required come uppermost, and switch on. A record can be rejected at any time after it has dropped on to the turntable by means of the ON-OFF-REJECT control. A record cannot be repeated unless it is repositioned on the loading spindle.

The heavy 10in. diameter, pressed steel turntable



Fig. 1.—Simple control by only two knobs, and economy of design, are two of the features of the versatile Monarch three-speed changer

(with rubber mat) is recessed into the baseplate and, together with the changer mechanism, is driven by a four-pole induction motor. The motor drives the turntable through a spring-loaded, intermediate 2in. rubber-tired wheel which bears upon its inside rim (Fig. 2). The wheel engages with a three-step drive bush attached to motor spindle. Steps on drive bush provide three different speeds, since, as the engraved speed control knob is turned, a lever connected to it raises or lowers the intermediate drive wheel so that it engages with the smallest diameter step (33½ rpm.), the middle step (45 rpm.) or the largest of the three which provides the fastest speed (78 rpm.).

A pinion gear on turntable hub transmits motive power to main gear 102 (Fig. 3) on underside of baseplate. This gear controls the whole cycle of operations.

The steel loading spindle incorporates a record feed lever and two record keepers. When records are placed on the spindle the feed lever is open and, in conjunction with a shoulder on the spindle, prevents them from dropping to the turntable. When the changer mechanism is put into operation, however, the lever momentarily closes and allows one record to fall. The rest are retained by the keepers which are specially shaped pieces of steel located in the top of the spindle.

Control arm (Fig. 2) serves a double purpose. It prevents records tilting and jamming on the loading spindle and also, through a series of levers, ensures that the mechanism is switched off after the last record has been played.

The spring-loaded selector arm is operated by the

record as it drops to the turntable. Its function is to position the pickup arm over the turntable for 10 or 12in. records. It does not operate on 7in. records, since the pickup is automatically adjusted to suit them if the selector arm is not actuated.

**PRINCIPLE OF OPERATION**

When the ON-OFF-REJECT control knob is set to ON, a lever 62 (Fig.3) attached to it operates the mains switch, and the turntable, driven through the intermediate wheel and the motor spindle, begins to revolve. The lever also moves forward to contact a link 98 (Light) friction coupled to an actuating pawl 100 on main gear 102. One section of this gear is without teeth, and at the beginning of the cycle of operations this is opposite the turntable hub which also has a gear attached.

The action of the lever pushes the actuating pawl forward to engage with a projection on turntable hub. This results in the main gear being impelled forward in an anti-clockwise direction and its teeth engaging with those of the turntable hub.

A cam 106 on the opposite face of main gear now moves the main slide 105 (Fig. 4) outward and away from turntable bearing. Coupled to this slide is a toggle slide 168 (Fig. 3) which in turn is linked to pickup raising and lowering spindle 152. Toggle slide moves forward and pickup arm is lifted off rest pillar. As the pickup spindle rises the smaller of its two springs 136 is compressed. This provides an upward pressure to spindle bracket 143 which locks it to the stop plate 148 (Fig. 4) until later in the cycle when the spindle is lowered.

Still moving outward, the main slide engages with reset pin on spindle bracket and the bracket turns in an anti-clockwise direction, rotating the stop plate to a fully-out position. This ensures that on its inward journey, the pickup will be correctly set for 7, 10 or 12in. records. Guide pin on main slide (now almost at the end of its outward movement) actuates the record feed lever 77 (Fig. 4) on loading spindle through link mechanism 114, 119 (Fig. 3). The lever closes and bottom record drops to turntable. Record keepers prevent other records moving laterally and ensure that only one is released.

As the record falls it operates selector arm 129 (Fig. 4) which, according to how far it is depressed, determines the position to which selector slide 131 can rise. The slide has vertical steps cut in its lower end. These engage with other steps cut horizontally on the stop plate. Each step represents a record size, and since the pickup bracket is locked to the stop plate, the combination of the steps engaged will decide how far out the pickup arm will be positioned before it is lowered on to the record.

Main slide now commences to move towards turntable bearing and releases reset pin on spindle bracket. Stop plate is spring-loaded and both plate and bracket, together with pickup arm, turn inward towards the record. Toggle slide also starts on its inward journey, the pickup spindle is lowered and the pickup comes down on the record.

Tension on spring 136 (Fig. 4) is released, spindle bracket is dis-engaged from stop plate and the pickup is quite free to travel across the record. As the pickup spindle is lowered, however, another spring 139 (on pickup spindle) is compressed; main slide and toggle slide are locked under its pressure, and cam 106, which operates main slide, is located in an indentation on it.

Main gear 102 has now completed a revolution,

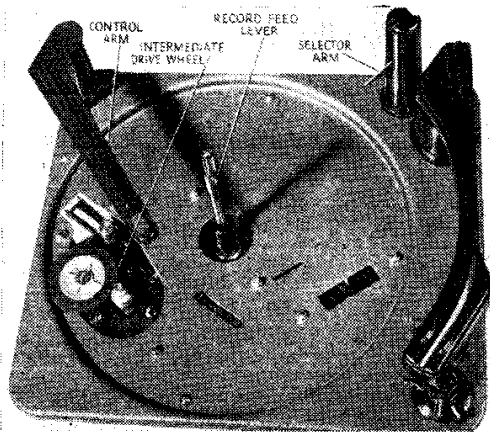

**Fig. 2—Top view of changer unit with turntable removed**

and while doing so has reset the friction link 98 and actuating pawl 100 against a reset spring 94 which extends over one face of the gear. The main gear is also provided with a ramp form which depresses reset arm 160. This arm is coupled to the selector slide 131 which in turn is pulled down, setting stop plate for 7in. record position. It should be noted that unless the selector arm is operated by a falling record, the pickup will always swing in and come down at the 7in. record position.

Having come full circle, the teeth on main gear have disengaged from gear on turntable hub. Turntable continues to revolve, and the pickup approaches the fast finishing groove on record. As it does so, the spindle bracket slowly turns inward and the reset pin 142 affixed to it pushes lever 96 towards the actuating pawl. As pickup swings forward on the record's eccentric groove, the lever thrusts the pawl against the hub projection, the projection engages with it and main gear is driven anti-clockwise. Pickup spindle rises and the pickup head is lifted off the record. Main slide moves outward away from turntable spindle, contacts reset pin on pickup spindle bracket (again locked to stop plate), and thus the pickup arm is turned back across the record, and, as the spindle is lowered, comes down on the rest pillar.

If there are records on the loading spindle the change cycle begins anew. But after the last record has fallen, the control arm drops to the full down position. Stop arm 167 and stop lever 165 (Fig. 3) come under tension from the spring 12 on stop pawl, and stop arm is positioned directly under stop pin 156. Cut off arm is moved forward into position for engagement with tongue on main gear. Reset arm 160 lifts as gear rotates and stop pin rises to the full extent of its travel.

Main slide would now normally return pickup arm to the record, but as the stop-pin is raised the stop plate is prevented from turning and the pickup remains poised over the stop pillar. The cycle continues, pickup is lowered, and just before the main gear reaches the neutral position, that is, with the cut-away section opposite turntable hub, the tongue on it operates the cut-off arm, which in turn actuates the lever connected to ON-OFF-REJECT switch. Switch is set in the OFF position and motor ceases to operate.

*Continued on page 6*

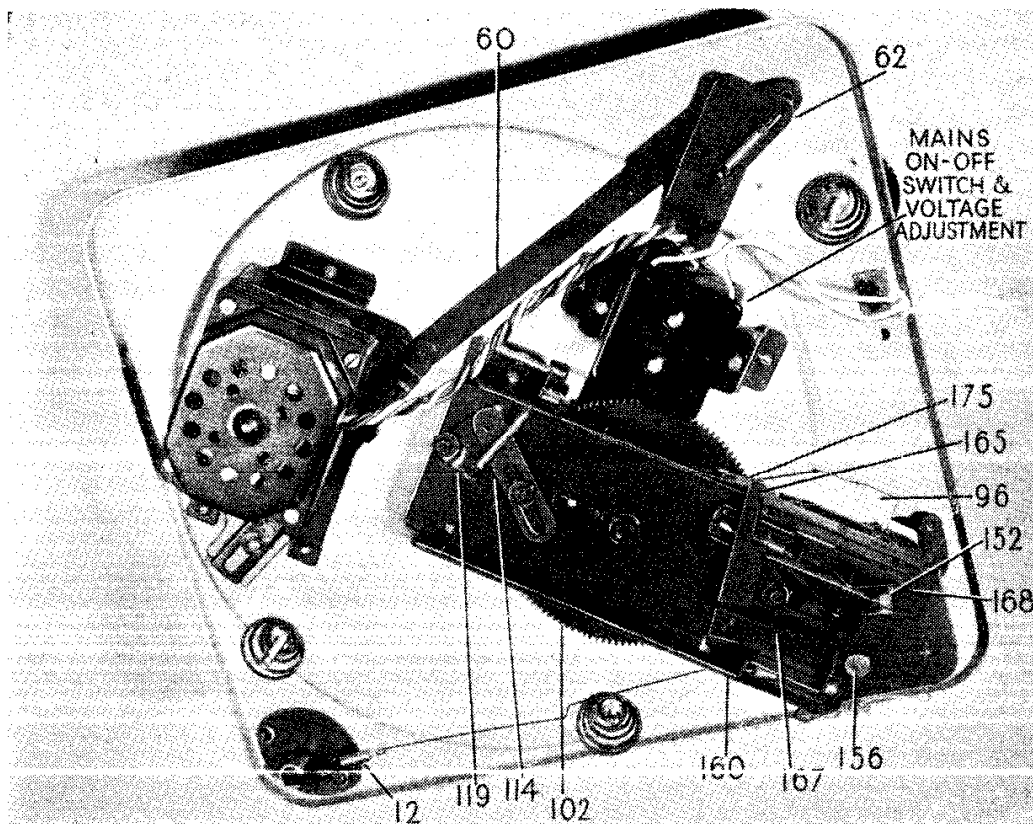

**Fig. 3—The mechanism has a minimum of moving parts**

**Fig. 4 — This sub-assembly is secured to the base plate by three screws**

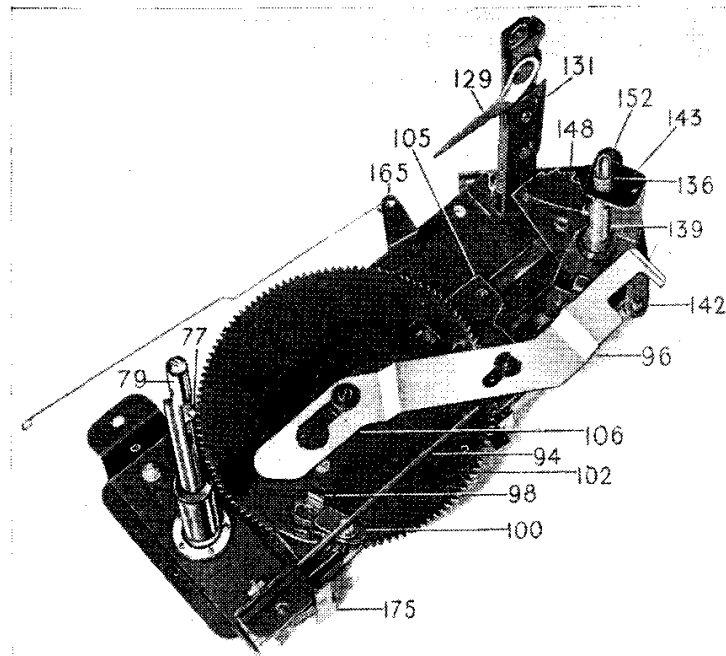

**Fig. 5—Details of pickup arm adjustments. Weight of needle on record should be 12-15 grams**

# BSR CHANGER

—Continued from page 2

Once on the turntable a record can be rejected at any stage by use of the REJECT control. Pickup arm is raised and returned to the rest pillar, the next record descends and the cycle of operations begins again. If the record loading spindle is empty, however, pickup is returned to rest and the motor switched off.

## ADJUSTMENTS

**Needle set down.** The set down position of the needle on the records is controlled by the needle-adjusting screw, or bending of the needle-adjusting tongue on certain models (Fig. 5). Adjust the screw or tongue until the correct set down of the needle on a 10in. record is obtained. The correct position is  $\frac{1}{4}$ in. from the edge of the record. It is advisable to make this adjustment with a number of 10in. records on the turntable. When correctly positioned for 10in., the 12 and 7in. needle set down will also be correct.

**Pickup arm height** is adjusted by the pickup height adjusting screw (Fig. 5). To raise the pickup arm, turn screw anti-clockwise; to lower, turn clockwise. Pickup height should be adjusted so that with a 1in. stack of records on the turntable, the point of the needle clears the top record by  $\frac{1}{16}$ in. Check that the pickup arm clears the underside of records loaded on the spindle.

**Needle pressure** should be between 12 and 15 grams. Adjustments may be made by bending the weight adjusting link (Fig. 5) until the correct pressure is obtained.

## DISMANTLING

**Removing turntable.** Remove circlip and lift turntable vertically upwards over centre spindle. Take care not to lose the thin thrust washer, that sticks to underside of turntable boss, ballrace or second thrust washer. Note: Before replacing assembly, set speed control knob to 45rpm. This allows easy manoeuvrability of drive wheel when replacing turntable, without possible danger of bending the arm.

**Removing control arm assembly.** Hold the sleeve that protrudes from base of control column moulding firmly in a vice, and with a hammer and punch drive the control spindle through the sleeve. On re-assembly, re-riveting can be accomplished by a number of dot punch indentations on the end of spindle around the circumference. This operation should only be undertaken when adequate mechanical facilities are available.

**Removing pickup arm assembly.** This must be done after the changer has switched itself off. Remove pickup overload spring, unsolder pickup leads from connecting tagstrip. Unscrew pickup top bearing and lift the pickup arm clear. Replace the pickup top bearing to avoid losing the spacer washer.

**Removing main sub-assembly.** Remove turntable and pickup arm. Uncouple the connecting link from stop pawl spring. Unscrew 2BA bolt at rear of selector cover and also remove bolts on bracket. Main sub-assembly can then be gently removed from unit-plate.

**Removing main gear assembly.** Remove circlip and actuating lever. Remove circlip from gear bearing. Slacken off 4BA bolt in support bracket and release pawl reset spring from between spring clamp plate and support bracket. Should pawl reset spring be secured by rivet, and not, therefore, easily

removable, it should be flexed out of the way of gear, care being taken not to bend it. Main gear assembly can then be lifted off bearing.

**Removing main slide.** Remove main gear assembly. Remove circlip and washer, slip record-feed link up and over end of guide pin. Remove washer, circlip and washer. Remove circlip and washer and unhook end of toggle slide return spring from toe of main slide.

**Removing pickup cartridge.** Turn cartridge round so that 10BA bolt can be unscrewed. Slide out knob. Cartridge should then gently be eased out of its cradle by pressing down against spring. Both spring and pivot are then loose. Slide back the short length of 4mm. PVC sleeving and pull out the two socket tags.

## MAINTENANCE

Motor bearings are of the oil retaining type and under normal operating conditions should require little attention.

Occasionally lubricate mechanism as follows: Remove turntable and apply two drops of medium grade oil to bearing; one or two drops to record feed lever; one drop to pickup raising and lowering spindle; two drops to cam under main gear; one drop to stop pin; one drop to control spindle.

**Needle replacement.** To replace needle hold worn one with a strong pair of tweezers and pull out at an angle of 25 degrees. The new needle should be eased into the needle housing until positioned identically to the needle on the reverse side of the cartridge. Great care should be taken when replacing the needle, as undue pressure might easily damage the crystal.

Note: The changer will not operate correctly unless it is standing level.

## POSSIBLE FAULTS AND REMEDIES

If turntable revolves when switch is turned to ON, but pickup remains stationary on rest, the knob is not being turned to its fullest extremity in the ON direction. If the knob is jammed and cannot be turned, rotate the turntable by hand clockwise until the fault is cleared.

Turntable will run slow if mains voltage is low, or the frequency is below 50c/s. It may also run slow if the changer has been standing in a cold place. Also check for binding of motor and turntable bearings.

If the last record has been played but the changer does not switch off, check that the control arm has dropped below offset shoulder of loading spindle. Oil if necessary.

Pickup arm striking record on spindle as it rises, or needle catching on record as it moves out, indicates that pickup arm height is incorrectly adjusted.

Changer continuing to cycle with pickup dropping on to record at each cycle indicates that the pawl reset spring is out of position. Adjust reset spring so that it engages with friction link shoulder as main gear is rotated. The spring should not be set too low or it will foul other components. Ensure that the spring fixing bolt is tightened after adjustment.

If pickup merely rises and falls on rest pillar, actuating lever is either jamming on top or slips to wrong side of reset pin.

When changer returns pickup to rest before the last record on loading spindle has dropped, turntable continues to revolve or mechanism is switched off, the stop bracket assembly is wrongly positioned.

Records failing to drop indicates either broken feed spindle in loading spindle, or broken feed lever.