

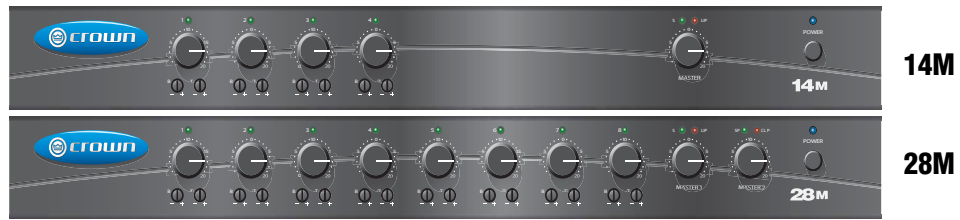

## Commercial Audio Series

Operation Manual



**Obtaining Other Language Versions:** To obtain information in another language about the use of this product, please contact your local Crown Distributor. If you need assistance locating your local distributor, please contact Crown at 574-294-8000.

This manual does not include all of the details of design, production, or variations of the equipment. Nor does it cover every possible situation which may arise during installation, operation or maintenance.

The information provided in this manual was deemed accurate as of the publication date. However, updates to this information may have occurred. To obtain the latest version of this manual, please visit the Crown website at [www.crownaudio.com](http://www.crownaudio.com).

**Trademark Notice:** Crown, Crown Audio and Amcron are registered trademarks of Crown International. Other trademarks are the property of their respective owners.

**Some models may be exported under the name Amcron.®**

©2008 by Crown Audio® Inc., 1718 W. Mishawaka Rd., Elkhart, Indiana 46517-9439 U.S.A. Telephone: 574-294-8200

**H** A Harman International Company

138097-4C  
2/08

## Important Safety Instructions

- 1) Read these instructions.
- 2) Keep these instructions.
- 3) Heed all warnings.
- 4) Follow all instructions.
- 5) Do not use this apparatus near water.
- 6) Clean only with a dry cloth.
- 7) Do not block any ventilation openings. Install in accordance with the manufacturer's instructions.
- 8) Do not install near any heat sources such as radiators, heat registers, stoves, or other apparatus (including amplifiers) that produce heat.
- 9) Do not defeat the safety purpose of the polarized or grounding-type plug. A polarized plug has two blades with one wider than the other. A grounding-type plug has two blades and a third grounding prong. The wide blade or the third prong is provided for your safety. If the provided plug does not fit into your outlet, consult an electrician for replacement of the obsolete outlet.
- 10) Protect the power cord from being walked on or pinched, particularly at plugs, convenience receptacles, and the point where they exit from the apparatus.
- 11) Only use attachments/accessories specified by the manufacturer.
- 12) Use only with a cart, stand, tripod, bracket, or table specified by the manufacturer, or sold with the apparatus. When a cart is used, use caution when moving the cart/apparatus combination to avoid injury from tip-over.
- 13) Unplug this apparatus during lightning storms or when unused for long periods of time.
- 14) Refer all servicing to qualified service personnel. Servicing is required when the apparatus has been damaged in any way, such as power-supply cord or plug is damaged, liquid has been spilled or objects have fallen into the apparatus, the apparatus has been exposed to rain or moisture, does not operate normally, or has been dropped.



- 15) WARNING: TO REDUCE THE RISK OF FIRE OR ELECTRIC SHOCK, DO NOT EXPOSE THIS APPARATUS TO RAIN OR MOISTURE.
- 16) DO NOT EXPOSE TO DRIPPING OR SPLASHING. DO NOT PLACE OBJECTS FILLED WITH LIQUID, SUCH AS VASES, ON THIS APPARATUS.



TO PREVENT ELECTRIC SHOCK DO NOT REMOVE TOP OR BOTTOM COVERS. NO USER SERVICEABLE PARTS INSIDE. REFER SERVICING TO QUALIFIED SERVICE PERSONNEL.

À PRÉVENIR LE CHOC ÉLECTRIQUE N'ENLEVEZ PAS LES COUVERCLES. IL N'Y A PAS DES PARTIES SERVICEABLE À L'INTÉRIEUR. TOUS REPARATIONS DOIT ÊTRE FAIRE PAR PERSONNEL QUALIFIÉ SEULMENT.

TO COMPLETELY DISCONNECT THIS EQUIPMENT FROM THE AC MAINS, DISCONNECT THE POWER SUPPLY CORD PLUG FROM THE AC RECEPTACLE. THE MAINS PLUG OF THE POWER SUPPLY CORD SHALL REMAIN READILY OPERABLE.

### WATCH FOR THESE SYMBOLS:

The lightning bolt triangle is used to alert the user to the risk of electric shock.

The exclamation point triangle is used to alert the user to important operating or maintenance instructions.



**CAUTION**  
RISK OF ELECTRIC SHOCK  
DO NOT OPEN

**AVIS**  
RISQUE DE CHOC ÉLECTRIQUE  
N'OUVREZ PAS

### FCC COMPLIANCE NOTICE

This device complies with part 15 of the FCC rules. Operation is subject to the following two conditions: (1) This device may not cause harmful interference, and (2) this device must accept any interference received, including interference that may cause undesired operation.

CAUTION: Changes or modifications not expressly approved by the party responsible for compliance could void the user's authority to operate the equipment.

NOTE: This equipment has been tested and found to comply with the limits for a Class B digital device, pursuant to part 15 of the FCC Rules. These limits are designed to provide reasonable protection against harmful interference in a residential installation. This equipment generates, uses, and can radiate radio frequency energy and, if not installed and used in accordance with the instruction manual, may cause harmful interference to radio communications. However, there is no guarantee that interference will not occur in a particular installation. If this equipment does cause harmful interference to radio or television reception, which can be determined by turning the equipment off and on, the user is encouraged to try to correct the interference by one or more of the following measures:

- Reorient or relocate the receiving antenna.
- Increase the separation between the equipment and receiver.
- Connect the equipment into an outlet on a circuit different from that to which the receiver is connected.
- Consult the dealer or an experienced radio/TV technician for help.



Crown International, Inc.

**DECLARATION of CONFORMITY**

**Issued By:** Crown International, Inc.  
1718 W. Mishawaka Road  
Elkhart, Indiana 46517 U.S.A.

FOR COMPLIANCE QUESTIONS ONLY: Sue Whittfield  
574-294-8289  
swhittfield@crowintl.com

**European Representative's Name and Address:**

David J. Budge  
10 Harvest Close  
Yateley  
GU46 6YS  
United Kingdom

**Equipment Type:** Commercial Audio Series**Family Name:** Mixers**Model Names:** 14M, 28M**EMC Standards:**

**EN 55103-1:1997** Electromagnetic Compatibility - Product Family Standard for Audio, Video, Audio-Visual and Entertainment Lighting Control Apparatus for Professional Use, Part 1: Emissions  
**EN 55103-1:1997** Magnetic Field Emissions-Annex A @ 10 cm and 1 M  
**EN 61000-3-2:2001** Limits for Harmonic Current Emissions (equipment input current 16A per phase)  
**EN 61000-3-3:2002** Limitation of Voltage Fluctuations and Flicker in Low-Voltage Supply Systems Rated Current 16A  
**EN 55022:2003** Limits and Methods of Measurement of Radio Disturbance Characteristics of ITE: Radiated, Class B Limits; Conducted, Class B  
**EN 55103-2:1997** Electromagnetic Compatibility - Product Family Standard for Audio, Video, Audio-Visual and Entertainment Lighting Control Apparatus for Professional Use, Part 2: Immunity  
**EN 61000-4-2:2001** Electrostatic Discharge Immunity (Environment E2-Criteria B, 4k V Contact, 8k V Air Discharge)  
**EN 61000-4-3:2001** Radiated, Radio-Frequency, Electromagnetic Immunity (Environment E2, Criteria A)  
**EN 61000-4-4:2001** Electrical Fast Transient/Burst Immunity (Criteria B)  
**EN 61000-4-5:2001** Surge Immunity (Criteria B)  
**EN 61000-4-6:2003** Immunity to Conducted Disturbances Induced by Radio-Frequency Fields (Criteria A)  
**EN 61000-4-11:2001** Voltage Dips, Short Interruptions and Voltage Variation

**Safety Standard:**

**IEC 60065: 2002 7th Ed.** Safety Requirements - Audio Video and Similar Electronic Apparatus  
**CAN/CSA-E60065-03 7th Ed.** Audio, Video and Similar Electronic Apparatus-Safety Requirements  
**UL 60065 7th Ed.** Audio /Video and Musical Instrument Apparatus for Household, Commercial and Similar General Use.

I certify that the product identified above conforms to the requirements of the EMC Council Directive 89/336/EEC as amended by 92/31/EEC, and the Low Voltage Directive 73/23/EES as amended by 93/68/EEC.

Signed



Larry Coburn

Title: Senior Vice President of Manufacturing

Date of Issue: Nov. 1, 2004

## Table of Contents

Important Safety Instructions.....	2	2.9 Powering Up .....	12
Declaration of Conformity .....	3	2.10 Included Accessories .....	12
<b>1 Welcome .....</b>	<b>5</b>	2.11 Block Diagram.....	13
1.1 Features .....	5	<b>3 Troubleshooting .....</b>	<b>14</b>
1.2 Front Panel Controls and Indicators.....	6	<b>4 Specifications .....</b>	<b>15</b>
1.3 Back Panel Controls and Connectors .....	7	<b>5 Service .....</b>	<b>16</b>
<b>2 Setup .....</b>	<b>8</b>	5.1 International and Canada Service.....	16
2.1 Installation .....	8	5.2 US Service .....	16
2.2 How to Attach Rack Ears.....	8	5.2.1 Service at a US Service Center .....	16
2.3 Choose Input Wire and Connectors.....	9	5.2.2 Factory Service .....	16
2.4 Choose Output Wire and Connectors .....	9	5.2.3 Factory Service Shipping Instructions.....	16
2.5 Wire Your System.....	10	5.2.4 Packing Instructions.....	16
2.6 Input Routing .....	11	5.2.5 Estimate Approval .....	16
2.7 Phantom Power .....	11	5.2.6 Payment of Non-Warranty Repairs .....	16
2.8 Priority Muting.....	11	<b>6 Warranty .....</b>	<b>17</b>
		Warranty Registration.....	19
		Crown Factory Service Information Form.....	21



## 1 Welcome

The Crown® 14M and 28M are high-value mixers for commercial and industrial audio. The mixers are part of Crown's Commercial Audio Series, which also includes mixer-amplifiers and power amplifiers. These low-cost units provide all necessary features in a simple building-block format.

The 14M has 4 inputs and 1 output channel. The 28M has 8 inputs and 2 output channels.

Some applications include schools, hospitals, factories, restaurant/retail, houses of worship, fitness facilities, A/V boardrooms, prisons, and small offices. Typical uses are paging, background music, security and evacuation instructions.

### 1.1 Features

- 4 or 8 inputs, 1 or 2 line outputs
- Ideal for commercial and industrial use
- Expandable by adding Crown Commercial Audio mixer-amps or Commercial Audio power amplifiers
- Balanced Phoenix-type mic/line inputs; RCA inputs
- Balanced Phoenix-type line outputs
- Any input can be sent to any output
- Independent Bass and Treble controls on each input
- Priority muting
- Protected by a fuse
- Three-Year, No-Fault, Fully Transferable Warranty completely protects your investment and guarantees its specifications

# 1 Welcome

## 1.2 Front Panel Controls and Indicators

### A. Input Signal Presence Indicator

Green LED, one for each input channel, illuminates when input signal exceeds  $-24$  dBu (line) or  $-70$  dBu (mic).

### B. Input Volume Controls

Microphone/line, four in 14M, eight in 28M. Detented potentiometers with knobs.

### C. Output Volume Controls

One per output channel. Detented potentiometer with knob.

### D. Output Signal Presence Indicator

Green LED, one for each output channel, illuminates when output signal level exceeds 100 mV.

### E. Clip Indicator

Red LED, one per output channel, illuminates at threshold of audible distortion.

### F. Power Indicator

Blue LED indicates power on.

### G, H. Tone Controls

Bass and Treble non-detented potentiometers on each input channel. Bass  $\pm 10$  dB at 100 Hz, Treble  $\pm 10$  dB at 10 kHz.

### I. Power Switch

Pushbutton on-off switch. The power switch does not affect the 24V DC auxiliary power input (letter "K" on next page).

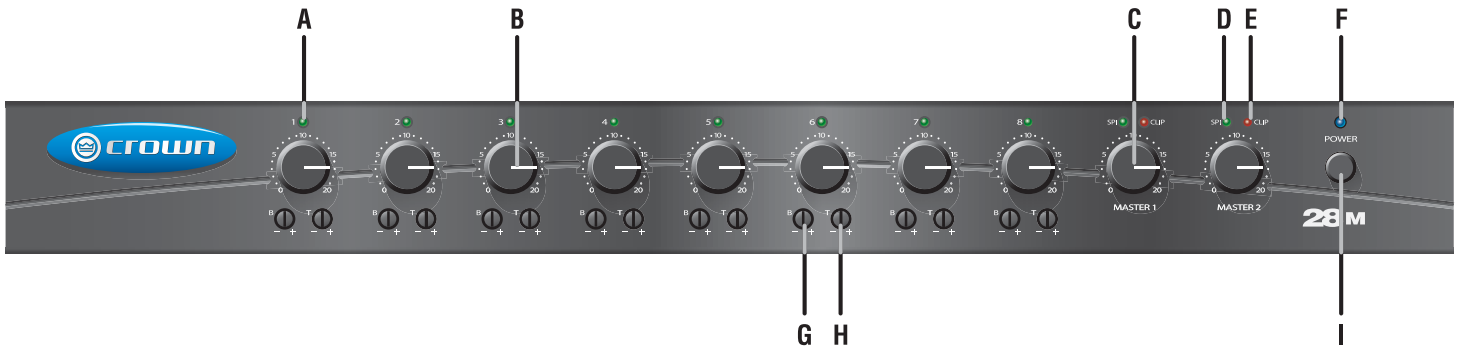

Figure 1.1 Front Panel Controls and Indicators

# 1 Welcome

## 1.3 Back Panel Controls and Connectors

**J. AC Power Inlet**  
Detachable IEC.

**K. Mixer Config Switch**  
A DIP switch with two functions:  
1. Assigns one of the inputs as the priority input for each output, thereby temporarily muting the remaining inputs. Muting is activated by contact closure.  
2. Global enable switch for phantom power. Does not affect RCA inputs. Default position is off.

**L. Input Routing Switch (28M only)**  
DIP switches that assign each input signal to each output. Two switches per input.

**M. Mic/line Switch**  
Selects mic-level or line-level input signals. One switch for each balanced input.

**N. Dual RCA Input Connector**  
For stereo music signals, unbalanced, summed together, two connectors per input channel. If required, both the mic/line and RCA inputs may be used at the same time. The mic/line gain switch does not affect the RCA gain, which is fixed relative to mic/line. The mic/line and RCA signals are mixed. Note: Other equipment connected to the RCA jacks should be connected to the same AC power source as the mixer to avoid hum.

**O. Mic/Line Input Connector**  
3-pin Phoenix-type, balanced, one per input channel.

**P. Fuse**  
Protects the power supply.

**Q Priority Connector**  
3-pin Phoenix-type connector allows Input 1 or Input 5 (28M only) to mute other input signals by contact closure.

**R. Auxiliary Power Input**  
2-position terminal strip for 24 VDC ( $\pm 10\%$ ) backup power. Accepts up to 10 AWG terminal forks. NOTE: To prevent a spark when attaching a battery, have unit turned on and connected to the mains supply.

**S. Line Out Connector**  
One 3-pin balanced Phoenix-type connector per output channel. Level controlled by master volume control.



The tone generator has been omitted. Call Crown Tech Support if you have tone generator questions.

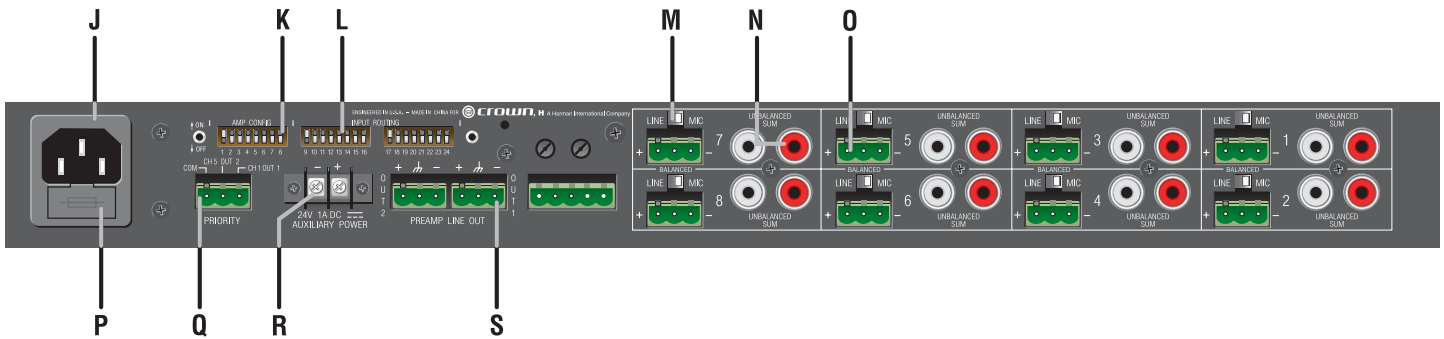

Figure 1.2 Back Panel Controls and Connectors (28M shown)

## 2 Setup

### 2.1 Installation

**CAUTION:** Before you begin, make sure your mixer is disconnected from the power source, with the power switch in the "off" position and all level controls turned completely down (counterclockwise).

Use a standard 19-inch (48.3 cm) equipment rack (EIA RS-310B). See Figure 2.1 for amplifier dimensions.

You may also stack mixers without using a cabinet, or you may place a single mixer on a surface.

**NOTE:** When transporting in a rack, mixers should be supported at the front and back.

The side walls of the rack should be a minimum of two inches (5.1 cm) away from the amplifier sides, and the back of the rack should be a minimum of four inches (10.2 cm) from the mixer back panel.

### 2.2 How to Attach Rack Ears

1. Locate the two rack ears supplied.
2. See Figure 2.2. Remove the two screws from each side of the chassis near the front.
3. Place a rack ear flush with the right front of the chassis.
4. Insert a screw that you removed into the bottom hole of the rack ear and chassis. Screw it in.
5. Insert a screw that you removed into the top hole of the rack ear and chassis. Screw it in.
6. Repeat steps 3-5 for the left side of the chassis.

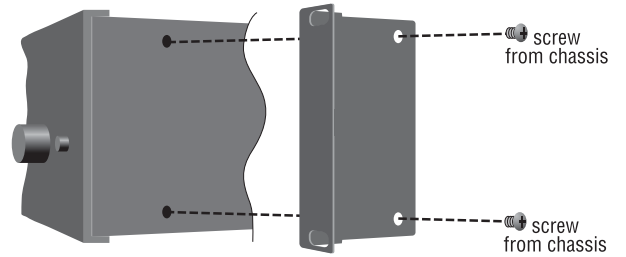

Figure 2.2 How to Connect Rack Ears

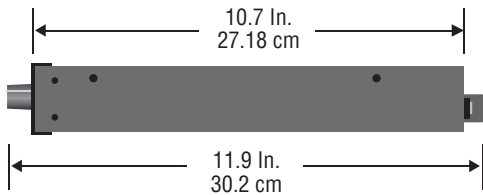
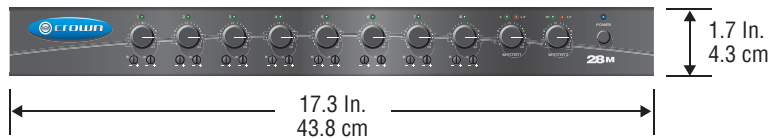

Figure 2.1 Dimensions



## 2 Setup

### 2.3 Choose Input Wire and Connectors

Crown recommends using pre-built or professionally wired balanced line (two-conductor plus shield), 22-24 gauge cables and connectors. You should use 3-pin Phoenix-type cable ends at the mixer inputs. Unbalanced line may also be used but may result in noise over long cable runs.

Figure 2.3 shows connector pin assignments for balanced wiring, and Figure 2.4 shows connector pin assignments for unbalanced wiring. The RCA input connectors can also be used for unbalanced inputs.



**NOTE: Custom wiring should only be performed by qualified personnel. Class 2 wiring is required.**

### 2.4 Choose Output Wire and Connectors

Use 2-conductor shielded cable and 3-pin Phoenix-type connectors for Line Output wiring (Figure 2.5).

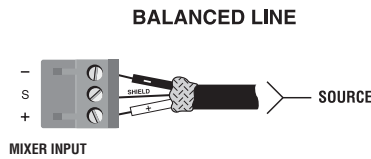

Figure 2.3 Balanced Input Connector Wiring



Figure 2.4 Unbalanced Input Connector Wiring

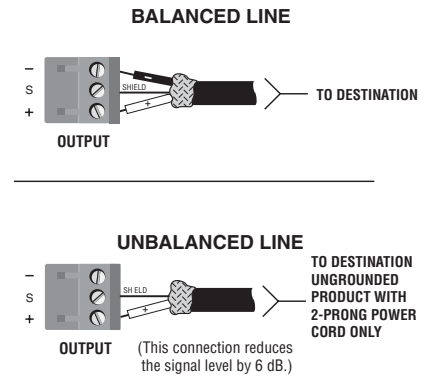

Figure 2.5 Line Out Wiring. Top: Balanced. Bottom: Unbalanced.

## 2 Setup

### 2.5 Wire Your System

Typical input and output wiring is shown in Figure 2.6.

**INPUTS:** Connect microphones or balanced line-level sources to mixer balanced inputs. Set Mic/Line switches accordingly. Connect unbalanced line-level signals to RCA input connectors.

**OUTPUTS:** Maintain proper polarity (+/-) on output connectors.

For more application drawings, see the enclosed *Commercial Audio Mixer Quick-Start Guide*.

**NOTE:** Crown provides a reference of wiring pin assignments for commonly used connector types in the *Crown Amplifier Application Guide* available at [www.crownaudio.com](http://www.crownaudio.com).

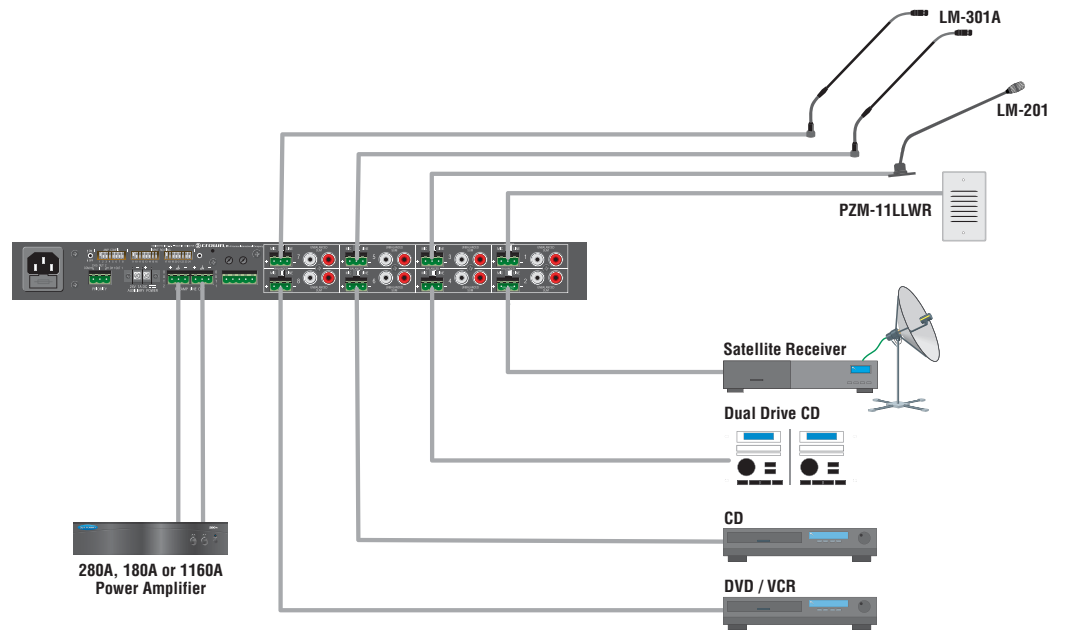

Figure 2.6 Input and Output Wiring

### 2.6 Input Routing

In the 28M, any input can be assigned to Output 1, Output 2 or both. The two DIP switches labeled INPUT ROUTING are used (Figure 2.7). Follow the settings printed on the back panel next to the INPUT ROUTING switch. For example, to send input Channel 3 to Output 1 and Output 2, turn on DIP switches 13 and 14.

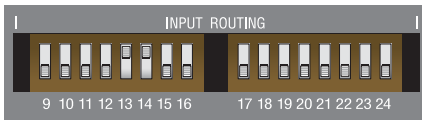

Figure 2.7 Input Routing DIP Switches

### 2.7 Phantom Power

To turn on phantom power on all mic inputs, turn on the switch number 7 in the AMP CONFIG DIP switch.

### 2.8 Priority Muting

A back-panel AMP CONFIG DIP switch (Figure 2.8) can assign Input Ch. 1 or Input Ch. 5 (28M only) as the priority input for each mixer output, which temporarily mutes the remaining inputs. Muting is activated by contact closures.

For example, suppose you configured Channel 1 as the priority input. Mic 1 is plugged into Channel 1. A press-to-talk switch in Mic 1 is wired to the Priority connector in the mixer-amplifier. When you press the mic switch, all other signals are muted so you can make an announcement on Mic 1.

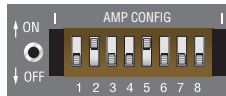

Figure 2.8 AMP CONFIG DIP Switch

One DIP-switch selection enables Channel 1 as the priority input, which mutes all other inputs to Out 1. In the 28M only, another DIP switch selection enables Channel 5 as the priority input, which mutes all other inputs to Out 2. In the 28M only, another set of DIP switches enable Channel 1 as the priority input into both Out 1 and Out 2, effectively muting any input.

#### To set the mixer for normal mode with no priority:

Set the OUT CONFIG DIP switch as follows:

- 1 ON
- 2 OFF
- 3 OFF
- 4 OFF
- 5 ON
- 6 OFF

#### To give priority to the Channel-1 input to Out 1 only:

Set the OUT CONFIG DIP switch as follows:

- 1 OFF
- 2 ON
- 3 OFF
- 4 OFF

Also, wire a SPST switch to the PRIORITY connector between COM and CH 1 OUT 1. Close the switch when you want the Channel-1 input to mute all other inputs feeding Out 1.

#### To give priority to the Channel-5 input to Out 2 only:

Set the OUT CONFIG DIP switch as follows:

- 5 OFF
- 6 ON

Also, wire a SPST switch to the PRIORITY connector between COM and CH 5 Out 2. Close the switch when you want the Channel-5 input to mute all other inputs feeding Out 2.

#### To give priority to the Channel-1 input to Out 1 and Out 2:

Set the OUT CONFIG DIP switch as follows:

- 1 OFF
- 2 ON
- 3 ON
- 4 ON

Also, wire a SPST switch to the PRIORITY connector between COM and CH1 Out 1. Close the switch when you want the Channel-1 input to mute all other inputs feeding Out 1 and Out 2.

Note: The routing configuration is extremely versatile. Many configurations for additional applications not highlighted in this document can be created by examining the signal flow in the block diagram on page 13.

## 2 Setup

### 2.9 Powering Up

1. Turn off any equipment connected to the Line Out connectors.
2. Plug the mixer's power cord into a 3-wire grounded AC outlet.
3. Turn down the input volume controls.
4. Turn down the master volume control.
5. Turn on the Power switch. The Power indicator should glow.
6. Turn the input volume controls in use about 3/4 up.
7. Have someone talk into a microphone. Turn up the master volume control(s) until the output clip LED flashes, then turn down the master volume control(s) about 1/4 turn for headroom.
8. Turn on any equipment connected to the Line Out connectors.
9. Turn up the power amplifier level control until the desired loudness or power level is achieved.
10. Touch up the input levels as needed for equal loudness from each microphone.

If you ever need to make any wiring or installation changes, disconnect the power cord.

### 2.10 Included Accessories

Power cord  
Detachable rack ears  
Screws for rack ears  
Phoenix-type connectors  
Spade lugs

## 2 Setup

### 2.11 Block Diagram

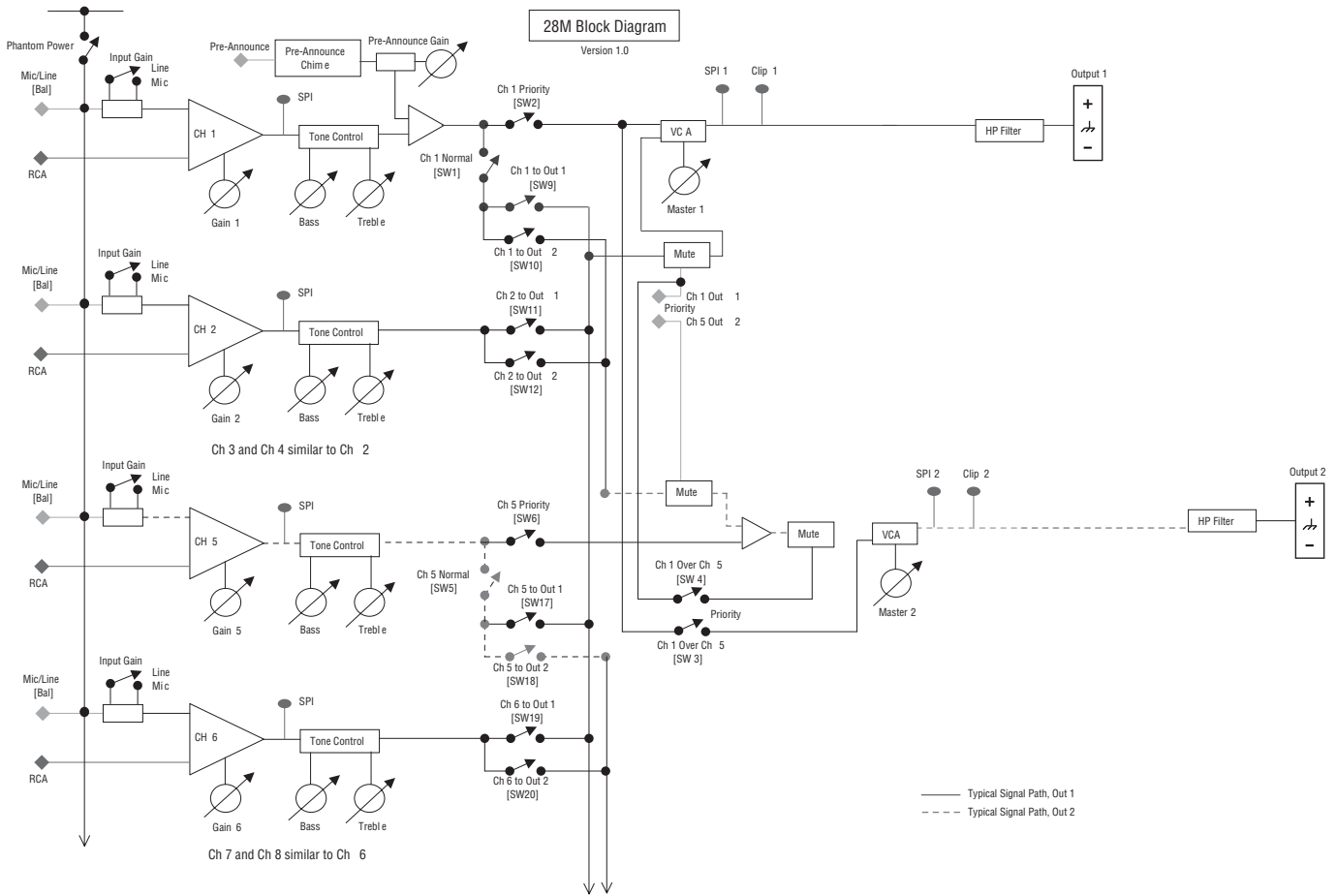

### 3 Troubleshooting



**CONDITION: No power to the mixer.**

**POSSIBLE REASON:**

- The mixer's Power switch is off.
- The mixer is not plugged into the power receptacle.
- The mixer's high-voltage power supply circuit fuse has opened. Verify that the AC mains voltage is correct, then press the Reset button on the back panel.
- If the unit is operated from a 24V DC supply, the internal fuse may have opened. (The power switch has no effect on 24V operation.)



**CONDITION: No sound.**

**POSSIBLE REASON:**

- Check the fuse and replace if necessary, or return mixer to Crown or an authorized Crown Service Center for servicing.



**CONDITION: Distorted sound.**

**POSSIBLE REASON:**

- Input signal level is too high. Turn down your input volume controls. NOTE: Your mixer should never be operated at a level which causes the Clip LEDs to illuminate constantly.
- Master volume level is too high. Turn it down to about 3/4 of maximum level.



- No input signal.
- Input signal level is very low.

## 4 Specifications

<b>Performance</b>	<b>14M</b>	<b>28M</b>
Number of input channels	4	8
Number of output channels	1	2
Input Sensitivity (volts RMS) for full output at maximum gain		
Balanced mic inputs	3 mV	3 mV
Balanced line inputs	800 mV	800 mV
RCA connectors	400 mV	400 mV
Frequency Response (at line out, 20 Hz to 20 kHz)	± 1 dB	± 1 dB
Signal to Noise Ratio (master volume at minimum)	100 dB	100 dB
Total Harmonic Distortion (THD) with 800 mV balanced input, 1V output	0.05% typical	0.05% typical
Input Impedance (nominal)	Mic: 400 ohms, Line: 100 kilohms, RCA: 50 kilohms	Mic: 400 ohms, Line: 100 kilohms, RCA: 50 kilohms
Crosstalk (all controls at "10")	-70 dB at 1 kHz	-70 dB at 1 kHz
Line Output Level (nominal)	1.2V into 10 kilohms	1.2V into 10 kilohms
Phantom Power	15 VDC	15 VDC
AC Line Voltages Available	100V 50/60 Hz 120V 60 Hz 220V 50/60 Hz 230V 50/60 Hz 240V 50/60 Hz	100V 50/60 Hz 120V 60 Hz 220V 50/60 Hz 230V 50/60 Hz 240V 50/60 Hz
Operating Temperature/Humidity	0° C to 40° C at 95% relative humidity (non-condensing)	0° C to 40° C at 95% relative humidity (non-condensing)
Storage Temperature	-20° C to 85° C	-20° C to 85° C
<b>Construction</b>	<b>14M</b>	<b>28M</b>
Dimensions: Width (with rack ears), Height, Depth (behind mounting surface)	EIA Standard 19"W (EIA RS-310-B) with rack ears x 1.7" (4.3 cm) H x 10.7" (27.18 cm) D	EIA Standard 19"W (EIA RS-310-B) with rack ears x 1.7" (4.3 cm) H x 10.7" (27.18 cm) D
Net Weight, Shipping Weight	8.7 lb (3.9 kg), 14 lb (6.4 kg)	8.7 lb (3.9 kg), 14 lb (6.4 kg)

## 5 Service

Crown mixers are quality units that rarely require servicing. Before returning your unit for servicing, please contact Crown Technical Support to verify the need for servicing.

This unit has very sophisticated circuitry which should only be serviced by a fully trained technician. This is one reason why each unit bears the following label:

**CAUTION: To prevent electric shock, do not remove covers. No user serviceable parts inside. Refer servicing to a qualified technician.**



Complete the Crown Audio Factory Service Information form, in the back of this manual, when returning a Crown product to the factory or authorized service center. The form must be included with your product inside the box or in a packing slip envelope securely attached to the outside of the shipping carton. Do not send this form separately.

*Warranty is only valid within the country in which the product is purchased.*

### 5.1 International and Canada Service

Service may be obtained from an authorized service center. (Contact your local Crown/Amcron representative or our office for a list of authorized service centers.) To obtain service, simply present the bill of sale as proof of purchase along with the defective unit to an authorized service center. They will handle the necessary paperwork and repair.

Remember to transport your unit in the original factory pack.

### 5.2 US Service

Service may be obtained in one of two ways: from an authorized service center or from the factory. You may choose either. It is important that you have your copy of the bill of sale as your proof of purchase.

#### 5.2.1 Service at a US Service Center

This method usually saves the most time and effort. Simply present your bill of sale along with the defective unit to an authorized service center to obtain service. They will handle the necessary paperwork and repair. Remember to transport the unit in the original factory pack. A list of authorized service centers in your area can

be obtained from Crown Factory Service, or online from <http://www.crownaudio.com/support/servcent.htm>.

#### 5.2.2 Factory Service

Crown accepts no responsibility for non-serviceable product that is sent to us for factory repair. It is the owner's responsibility to ensure that their product is serviceable prior to sending it to the factory. Serviceable product list is available at <http://crownweb.crownintl.com/crownrma/>. For more information, please contact us direct.

A Service Return Authorization (SRA) is required for product being sent to the factory for repair. An SRA can be completed online at [www.crownaudio.com/support/factserv.htm](http://www.crownaudio.com/support/factserv.htm). If you do not have access to the web, please call Crown's Customer Service at 574.294.8200 or 800.342.6939 extension 8205.

For warranty service, we will pay for ground shipping both ways in the United States. Contact Crown Customer Service to obtain prepaid shipping labels prior to sending the unit. Or, if you prefer, you may prepay the cost of shipping, and Crown will reimburse you. Send copies of the shipping receipts to Crown to receive reimbursement. Your repaired unit will be returned via UPS ground. Please contact us if other arrangements are required.

#### 5.2.3 Factory Service Shipping Instructions:

1. Service Return Authorization (SRA) is required for product being sent to the factory for service. Please complete the SRA by going to [www.crownaudio.com/support/factserv.htm](http://www.crownaudio.com/support/factserv.htm). If you do not have access to our website, call 1.800.342.6939, extension 8205 and we'll create the SRA for you.
2. See packing instructions that follow.
3. Ship product to:  
CROWN AUDIO FACTORY SERVICE  
1718 W MISHAWKA RD.  
ELKHART, IN 46517
4. Use a bold black marker and write the SRA number on three sides of the box.
5. Record the SRA number for future reference. The SRA number can be used to check the repair status.

#### 5.2.4 Packing Instructions

**Important:** These instructions must be followed. If they are not followed, Crown Audio, Inc. assumes no responsibility for damaged goods and/or accessories that are sent with your unit.

1. Fill out and include the Crown Audio Factory Service Information sheet in the back of this manual.
2. Do not ship any accessories (manuals, cords, hardware, etc.) with your unit. These items are not needed to service your product. We will not be responsible for these items.
3. When shipping your Crown product, it is important that it has adequate protection. We recommend you use the original pack material when returning the product for repair (Figure 9.1). If you do not have the original box, please call Crown at 800.342.6939 or 574.294.8210 and order new pack material. (Do not ship your unit in a wood or metal cabinet.)
4. If you provide your own shipping pack, the minimum recommended requirements for materials are as follows:
  - a. 275 P.S.I. burst test, Double-Wall carton that allows for 2-inch solid Styrofoam on all six sides of unit or 3 inches of plastic bubble wrap on all six sides of unit.
  - b. Securely seal the package with an adequate carton sealing tape.
  - c. Do not use light boxes or "peanuts". Damage caused by poor packaging will not be covered under warranty.

Enclose the completed Crown Audio Factory Service Information form (or securely attach it to the outside of carton) and re-seal the shipping pack with a sturdy carton sealing tape.

#### 5.2.5 Estimate Approval

Approval of estimate must be given within 30 days after being notified by Crown Audio Inc. Units still in the possession of Crown after 30 days of the estimate will become the property of Crown Audio Inc.

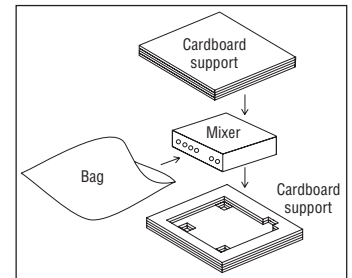

*Packing Assembly*

#### 5.2.6 Payment of Non-Warranty Repairs

Payment on out-of-warranty repairs must be received within 30 days of the repair date. Units unclaimed after 30 days become the property of Crown Audio Inc.

If you have any questions, please contact Crown Factory Service.

#### **Crown Factory Service**

1718 W. Mishawaka Rd.,  
Elkhart, Indiana 46517 U.S.A.

#### **Telephone:**

574.294.8200  
800.342.6939 (North America,  
Puerto Rico, and Virgin Islands only)

#### **Facsimile:**

574.294.8301 (Technical Support)  
574.294.8124 (Factory Service)

#### **Internet:**

<http://www.crownaudio.com>



## 6 Warranty



### SUMMARY OF WARRANTY

Crown International, 1718 West Mishawaka Road, Elkhart, Indiana 46517-4095 U.S.A. warrants to you, the ORIGINAL PURCHASER and ANY SUBSEQUENT OWNER of each NEW Crown product, for a period of three (3) years from the date of purchase by the original purchaser (the "warranty period") that the new Crown product is free of defects in materials and workmanship. We further warrant the new Crown product regardless of the reason for failure, except as excluded in this Warranty.

*Warranty is only valid within the country in which the product was purchased.*

### ITEMS EXCLUDED FROM THIS CROWN WARRANTY

This Crown Warranty is in effect only for failure of a new Crown product which occurred within the Warranty Period. It does not cover any product which has been damaged because of any intentional misuse, accident, negligence, or loss which is covered under any of your insurance contracts. This Crown Warranty also does not extend to the new Crown product if the serial number has been defaced, altered, or removed.

### WHAT THE WARRANTOR WILL DO

We will remedy any defect, regardless of the reason for failure (except as excluded), by repair, replacement, or refund. We may not elect refund unless you agree, or unless we are unable to provide replacement, and repair is not practical or cannot be timely made. If a refund is elected, then you must make the defective or malfunctioning product available to us free and clear of all liens or other encumbrances. The refund will be equal to

### UNITED STATES & CANADA

the actual purchase price, not including interest, insurance, closing costs, and other finance charges less a reasonable depreciation on the product from the date of original purchase. Warranty work can only be performed at our authorized service centers or at the factory. Warranty work for some products can only be performed at our factory. We will remedy the defect and ship the product from the service center or our factory within a reasonable time after receipt of the defective product at our authorized service center or our factory. All expenses in remedying the defect, including surface shipping costs in the United States, will be borne by us. (You must bear the expense of shipping the product between any foreign country and the port of entry in the United States including the return shipment, and all taxes, duties, and other customs fees for such foreign shipments.)

### HOW TO OBTAIN WARRANTY SERVICE

You must notify us of your need for warranty service within the warranty period. All components must be shipped in a factory pack, which, if needed, may be obtained from us free of charge. Corrective action will be taken within a reasonable time of the date of receipt of the defective product by us or our authorized service center. If the repairs made by us or our authorized service center are not satisfactory, notify us or our authorized service center immediately.

### DISCLAIMER OF CONSEQUENTIAL AND INCIDENTAL DAMAGES

YOU ARE NOT ENTITLED TO RECOVER FROM US ANY INCIDENTAL DAMAGES RESULTING FROM ANY DEFECT IN THE NEW CROWN PRODUCT.

THIS INCLUDES ANY DAMAGE TO ANOTHER PRODUCT OR PRODUCTS RESULTING FROM SUCH A DEFECT. SOME STATES DO NOT ALLOW THE EXCLUSION OR LIMITATIONS OF INCIDENTAL OR CONSEQUENTIAL DAMAGES, SO THE ABOVE LIMITATION OR EXCLUSION MAY NOT APPLY TO YOU.

### WARRANTY ALTERATIONS

No person has the authority to enlarge, amend, or modify this Crown Warranty. This Crown Warranty is not extended by the length of time which you are deprived of the use of the new Crown product. Repairs and replacement parts provided under the terms of this Crown Warranty shall carry only the unexpired portion of this Crown Warranty.

### DESIGN CHANGES

We reserve the right to change the design of any product from time to time without notice and with no obligation to make corresponding changes in products previously manufactured.

### LEGAL REMEDIES OF PURCHASER

THIS CROWN WARRANTY GIVES YOU SPECIFIC LEGAL RIGHTS. YOU MAY ALSO HAVE OTHER RIGHTS WHICH VARY FROM STATE TO STATE. No action to enforce this Crown Warranty shall be commenced after expiration of the warranty period.

THIS STATEMENT OF WARRANTY SUPERSEDES ANY OTHERS CONTAINED IN THIS MANUAL FOR CROWN PRODUCTS. 9/07

## 6 Warranty



### SUMMARY OF WARRANTY

Crown International, 1718 West Mishawaka Road, Elkhart, Indiana 46517-4095 U.S.A. warrants to you, the ORIGINAL PURCHASER and ANY SUBSEQUENT OWNER of each NEW Crown<sup>1</sup> product, for a period of three (3) years from the date of purchase by the original purchaser (the "warranty period") that the new Crown product is free of defects in materials and workmanship, and we further warrant the new Crown product regardless of the reason for failure, except as excluded in this Warranty.

*Warranty is only valid within the country in which the product is purchased.*

<sup>1</sup> Note: If your unit bears the name "Amcron," please substitute it for the name "Crown" in this warranty.

### ITEMS EXCLUDED FROM THIS CROWN-WARRANTY

This Crown Warranty is in effect only for failure of a new Crown product which occurred within the Warranty Period. It does not cover any product which has been damaged because of any intentional misuse, accident, negligence, or loss which is covered under any of your insurance contracts. This Crown Warranty also does not extend to the new Crown product if the serial number has been defaced, altered, or removed.

### WORLDWIDE EXCEPT USA & CANADA

#### WHAT THE WARRANTOR WILL DO

We will remedy any defect, regardless of the reason for failure (except as excluded), by repair, replacement, or refund. We may not elect refund unless you agree, or unless we are unable to provide replacement, and repair is not practical or cannot be timely made. If a refund is elected, then you must make the defective or malfunctioning product available to us free and clear of all liens or other encumbrances. The refund will be equal to the actual purchase price, not including interest, insurance, closing costs, and other finance charges less a reasonable depreciation on the product from the date of original purchase. Warranty work can only be performed at our authorized service centers. We will remedy the defect and ship the product from the service center within a reasonable time after receipt of the defective product at our authorized service center.

#### HOW TO OBTAIN WARRANTY SERVICE

You must notify your local Crown importer of your need for warranty service within the warranty period. All components must be shipped in the original box. Corrective action will be taken within a reasonable time of the date of receipt of the defective product by our authorized service center. If the repairs made by our authorized service center are not satisfactory, notify our authorized service center immediately.

#### DISCLAIMER OF CONSEQUENTIAL AND INCIDENTAL DAMAGES

YOU ARE NOT ENTITLED TO RECOVER FROM US ANY INCIDENTAL DAMAGES RESULTING FROM ANY DEFECT IN THE NEW CROWN PRODUCT. THIS INCLUDES ANY DAMAGE TO ANOTHER PRODUCT OR PRODUCTS RESULTING FROM SUCH A DEFECT.

#### WARRANTY ALTERATIONS

No person has the authority to enlarge, amend, or modify this Crown Warranty. This Crown Warranty is not extended by the length of time which you are deprived of the use of the new Crown product. Repairs and replacement parts provided under the terms of this Crown Warranty shall carry only the unexpired portion of this Crown Warranty.

#### DESIGN CHANGES

We reserve the right to change the design of any product from time to time without notice and with no obligation to make corresponding changes in products previously manufactured.

#### LEGAL REMEDIES OF PURCHASER

No action to enforce this Crown Warranty shall be commenced after expiration of the warranty period.

THIS STATEMENT OF WARRANTY SUPERSEDES ANY OTHERS CONTAINED IN THIS MANUAL FOR CROWN PRODUCTS. 9/07



**CROWN**

## PRODUCT REGISTRATION

Crown Audio, Inc.  
1718 W. Mishawaka Rd.  
Elkhart, IN 46517-9439  
Phone: 574-294-8000  
Fax: 574-294-8329  
www.crownaudio.com

Online registration is also available at <http://crownweb.crownintl.com/webregistration>.

*Warranty is only valid within the country in which the product is purchased.*

When this form is used to register your product, it may be mailed or faxed.

Crown Audio, Inc.      Fax: 574-294-8329  
1718 W Mishawaka Rd  
Elkhart IN 46517

Please note that some information is required. Incomplete registrations will not be processed. \* Indicates required information.

### OWNER'S INFORMATION - PLEASE PRINT

\* First name: \_\_\_\_\_ Middle initial: \_\_\_\_\_ \* Last name: \_\_\_\_\_  
Company: \_\_\_\_\_  
\* Mailing address: \_\_\_\_\_  
\* City: \_\_\_\_\_ \* State: \_\_\_\_\_ \* Zip Code: \_\_\_\_\_  
\* Country: \_\_\_\_\_ E-mail address: \_\_\_\_\_  
\* Phone # (include area code): \_\_\_\_\_ Fax #: \_\_\_\_\_

### PRODUCT INFORMATION

* MODEL	* SERIAL #	* PURCHASE DATE
e.g. IT8000, CDi1000, PCC160	e.g. 8000000000	mo/day/yr
_____	_____	____/____/____
_____	_____	____/____/____
_____	_____	____/____/____

Product purchased from: \*(Business/Individual) \_\_\_\_\_ Country: \_\_\_\_\_

Comments: \_\_\_\_\_  
\_\_\_\_\_  
\_\_\_\_\_

CUT ON THIS LINE

THIS PAGE INTENTIONALLY LEFT BLANK



### Crown Audio Factory Service Information

Shipping Address: Crown Audio Factory Service, 1718 W. Mishawaka Rd., Elkhart, IN 46517

**PLEASE PRINT CLEARLY**

SRA #: \_\_\_\_\_ (If sending product to Crown factory service.)      Model: \_\_\_\_\_      Serial Number: \_\_\_\_\_      Purchase Date: \_\_\_\_\_

**PRODUCT RETURN INFORMATION**

Individual or Business Name: \_\_\_\_\_

Phone #: \_\_\_\_\_      Fax #: \_\_\_\_\_      E-Mail: \_\_\_\_\_

Street Address (please, no P.O. Boxes): \_\_\_\_\_

City: \_\_\_\_\_      State/Prov: \_\_\_\_\_      Postal Code: \_\_\_\_\_      Country: \_\_\_\_\_

Nature of problem: \_\_\_\_\_

\_\_\_\_\_

\_\_\_\_\_

Other equipment in your system: \_\_\_\_\_

If warranty is expired, please provide method of payment. Proof of purchase may be required to validate warranty.

**PAYMENT OPTIONS**

I have open account payment terms. Purchase order required. PO#: \_\_\_\_\_       COD

Credit Card (Information below is required; however if you do not want to provide this information at this time, we will contact you when your unit is repaired for the information.)

**Credit card information:**

Type of credit card:     MasterCard             Visa             American Express             Discover

Type of credit card account:     Personal/Consumer             Business/Corporate

Card # \_\_\_\_\_ Exp. date: \_\_\_\_\_ \* Card ID #: \_\_\_\_\_

\* Card ID # is located on the back of the card following the credit card #, in the signature area. On American Express, it may be located on the front of the card. This number is required to process the charge to your account. If you do not want to provide it at this time, we will call you to obtain this number when the repair of your unit is complete.

Name on credit card: \_\_\_\_\_

Billing address of credit card: \_\_\_\_\_

\_\_\_\_\_

\_\_\_\_\_

THIS PAGE INTENTIONALLY LEFT BLANK

THIS PAGE INTENTIONALLY LEFT BLANK



**H** A Harman International Company