

**The Return of a  
Legend**

**DYNACO®**

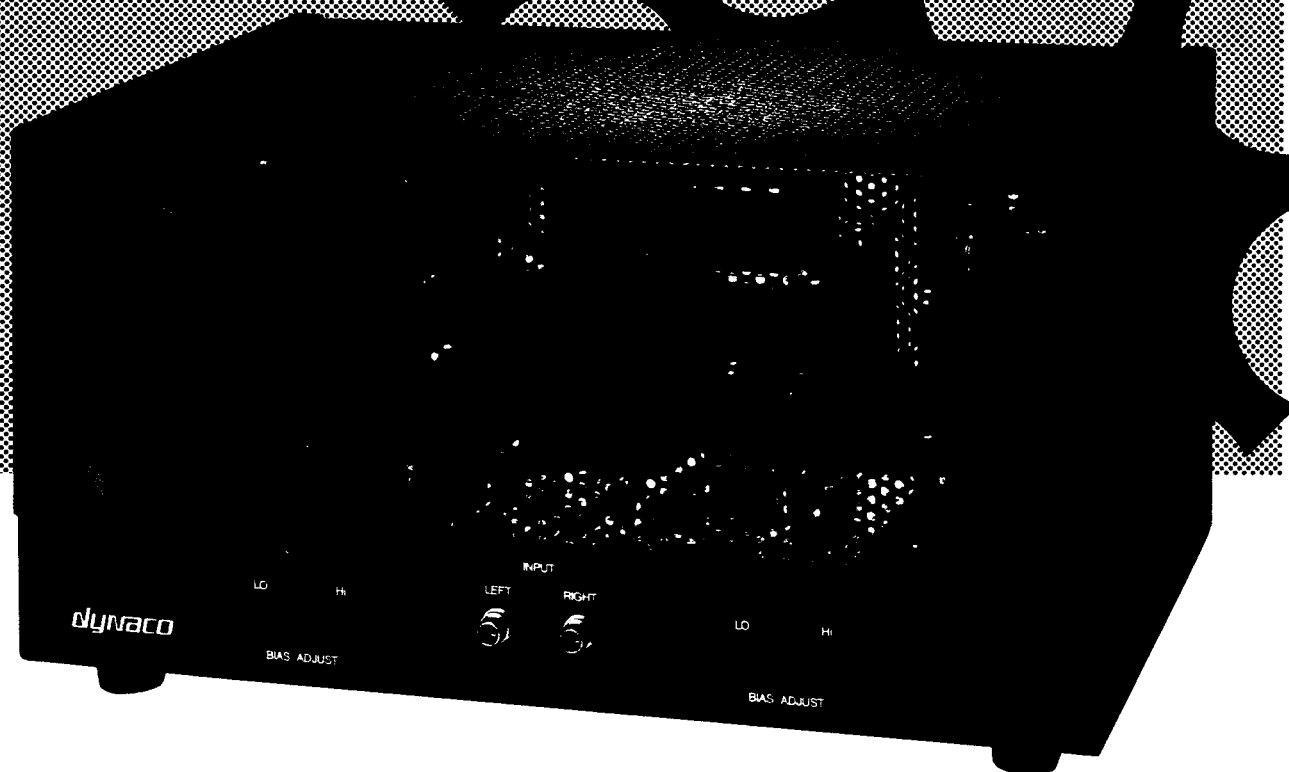

# Stereo 70

*Series II Tube Amplifier*

---

# ***dynaco***

## **STEREO 70 "SERIES II" AMPLIFIER**

**CONGRATULATIONS** on your choice of the *Dynaco "Series II" Stereo 70* tube amplifier. A medium-power "Class A push-pull" design, the "Series II 70" represents a thoroughly redesigned and modernized version of *the most popular stereo tube amplifier of all time*.

**INTRODUCTION.** Tens of thousands of original Dynaco tube amplifiers are still in use around the world. In fact, more quality music systems have included Dynaco tube preamps and power amplifiers than any other combination. The original Dynaco Stereo 70 is a *true classic* still regarded with awe by audio enthusiasts worldwide. The ST70 II marks the introduction of the second generation of vacuum tube products bearing the Dynaco name. This "new 70" fully reflects both the illustrious history of Dynaco's involvement with vacuum tube designs as well as the latest advances in tube circuit technology.

Through its long history, the Stereo 70 has proven a robust, reliable design of exceptional value. Dynaco has sought to preserve the considerable virtues of the original 70 while making fullest use of much better and more modern parts plus advanced circuit techniques. When comparing "old 70" with "new 70," one cannot help but notice the *external* similarity (i.e., the metalwork is of identical dimension but with an entirely new connector array). *Internally*, however, the two units differ radically from each other in both general appearance and execution of design. (Gone, for example, is nearly two-thirds of all internal connecting wire.)

**TUBE VS. TRANSISTOR.** Tube amplifiers are **THE** choice among many knowledgeable audiophiles, and they are preferred in severe service applications where even short-term failure must be avoided. Tube designs are inherently able to withstand user and signal abuse that would instantly damage solid-state electronics. Field replacement of socketed tubes is much more convenient than solid-state parts. Generally speaking, tube amplifiers will give warning of impending breakdown. Sonically, tube amplifiers do not clip as harshly as their solid state counterparts. Upon clipping, solid-state amplifiers abruptly limit the signal resulting in the generation of high level distortion components (simulating a square wave if driven hard enough). By contrast, tube circuits "soft clip" (resulting in a more pleasant compression rather than harsh clip). Ideally, neither is desirable. But a tube amplifier of modest power specification can sound as full and rich as a very large, solid-state amplifier on dynamically rich music passages. It is precisely these characteristics which are responsible for the "tube sound" so prized by audio enthusiasts. Tube amplifiers are regarded by many as "more musical" even though their measured specifications often appear far inferior to a comparably powered solid-state unit.

**DESIGN PHILOSOPHY.** Your ST70 Series II amplifier draws upon the proven design philosophies of the original 70. The low open-loop gain philosophy is maintained, thereby minimizing Transient Intermodulation Distortion (TIM). TIM distortion is regarded in many circles as the type of distortion to which the ear is most sensitive. The Pentode/Triode gain circuitry is virtually the same as original, thus keeping the signal path as short as practical without unnecessary distortion inducing complexity. This is the true elegance of the Stereo 70. The output tubes remain the fine EL34/6CA7's.

The excellent output transformers are also unchanged from the original ST70. Three output impedances are still available (i.e., 4, 8, and 16 ohm) -- all properly matched with equal power ratings.

---

---

Dynaco has made extensive use of the most modern parts in the ST70 II. Precision metal-film resistors, poly-composition capacitors and miniaturized high-capacity power supply electrolytics (unavailable at the time of the original design). Newer parts are also more conservatively rated than some of the original parts. In compliance with general practices, a heavy-duty three-pin grounded power cord is provided. *Signal ground is the same as electrical ground and chassis.* All signal connectors are gold-plated. The speaker connections are 5-way binding posts ready to accommodate any connection method you choose, from bare wire ends to 3/4" spaced banana connector pairs.

The original ST70's power supply has long been the design area most vulnerable to legitimate criticism. Dynaco has addressed this problem as follows:

- Use of an entirely new and larger dual primary power transformer with improved line regulation (due to added iron in its core). Can now be wired for 220 volt / 50 Hertz operation.
- The original 5AR4 tube has been replaced by solid-state rectifiers, thus removing the 5AR4's inherent losses and reduced regulation, while eliminating a failure-prone tube in the process. (Note: Original high quality "large-globe" 5AR4's are out-of-production and unavailable.)
- The original power supply filter capacitance has more than TRIPLED. This has been desirable for a long time but has only recently become practical (i.e., much greater capacitance can now be packaged in casings of diminutive size.)
- The troublesome selenium rectifier used in the bias circuitry has also been replaced by a solid-state rectifier with additional supply capacitance.
- The filter inductor has been reduced in value to complement the increase in filter capacitance with a resulting reduction of DC resistance. This provides more voltage for use by the outputs and results in higher power output.

All of the above changes serve to improve "stiffness" of the power supply by lowering the effective power supply impedance and improving regulation while increasing available voltage for maximum safe power output. It is Dynaco's position that full electronic regulation of the plate power supply does not result in cost effective sonic improvement.

The original ST70 design made use of roll-offs within the active circuitry to tailor the frequency response of the amplifier -- reducing open-loop gain at the frequency extremes. This open-loop gain reduction resulted in the characteristic distortion increase at the frequency extremes in the original design. Extensive testing and analysis has revealed that roll-offs may not be the most appropriate form of response limiting. Dynaco has installed an input frequency limiting filter network to limit bandwidth to 20 to 20,000Hz (long regarded as the human hearing range). This filter allows the removal of the tailoring components within the active circuitry and permits the active gain circuitry to be flatter across the frequency spectrum. The audible benefit is a great improvement in distortion components at the frequency extremes while still maintaining adequate bandwidth. *This network requires the drive impedance from the preamplifier to be less than 2K ohms for proper top end response.* This is acceptable for most modern day preamplifiers. Even tube types frequently achieve less than 2K using cathode follower output drivers. This also minimizes the effect of cable capacitance between the preamplifier and the power amp. It is possible to change C12 and C22 to permit higher impedance drives if absolutely necessary.

A further improvement in distortion, particularly in the higher frequencies, was achieved by moving the *feedback point* from the 16 ohm tap of the output transformer to the actual loaded 8 ohm tap. Since

---

---

the most often loaded tap is the 8 ohm tap, the feedback from this point eliminates the distortion caused by imperfect coupling of the signal through an unloaded (16 ohm) tap. Gain resistors have been altered to compensate gain back to normal. Transient response is improved.

The original ST70's signal tube [7199] is out-of-production and unavailable. The ST70 II uses, instead, the **6GH8A**. Since this tube has been extensively used in high-frequency applications, availability is excellent. It works *exceptionally* well in this application, yielding better consistency and lower distortion. (TECHNICAL NOTE: Though most tube manuals do not list a noise spec for the 6GH8A, extensive testing by Dynaco of large numbers of 6GH8A tubes has revealed noise floors that are, on average, lower than modern production 7199's. The 6GH8A is NOT a drop-in replacement for the 7199 tube as pinout for the two tubes is different. Do not attempt to interchange them.)

The printed circuit board material of the original ST70 was exposed economical phenolic which deteriorated with age creating unpredictable electrical changes resulting in sonic differences. The Series II unit uses military-grade, double sided epoxyfiberglass PC material and shields the recessed PCB with a metal cover plate. The board is also populated by the finest parts. Sensitivity to internal wiring placement is eliminated since wiring to the output tubes is accomplished via the Printed Circuit Panel. In fact, nearly two-thirds of the trouble-prone original point-to-point wiring has been eliminated!

## OPERATING INSTRUCTIONS

### INSTALLATION

The ST70 II should be located so that its LED front panel is accessible and visible. This will greatly facilitate the required periodic adjustment of bias potentiometers and LED display. If the amplifier is to be mounted near a phono cartridge, you should check to be sure the cartridge does not pick up hum from the power transformer. Convenient as it may appear, the top of the amplifier should never be used as a "shelf." **NOTHING SHOULD EVER BE PLACED ON TOP OF THE ST70 II!**

**VENTILATION** is a particularly important consideration with a vacuum tube amplifier. It is normal for the ST70 II to get quite hot directly over the power output tubes. Though it runs cooler than its predecessor, **ADEQUATE AIR CIRCULATION IS STILL ESSENTIAL -- at least one foot of space above it and a few inches all around.** Be sure to allow the unit this free access to fresh air to avoid excessive heat buildup. The ST70 II is intended to be installed so that it sits on its four rubber feet with a free flow of air under its bottom plate.

The protective cover which is supplied with the Stereo 70 II has been designed to be both functional and good looking. It should be used on the amplifier if the amplifier is located where it can be inadvertently touched. Although the circuit board voltages are kept from probing fingers by a protective metal cover plate, the tubes get hot in normal operation, and touching them can result in a minor burn. Therefore, the protective cover should always be used.

---

---

## CONNECTIONS

### AC Power

The power cord should be plugged into a 3-wire grounded *wall outlet* providing 120 volts, 50/60Hz on a 15 amp (minimum) circuit. If a matching outlet is not available, an adaptor with separate ground wire may be obtained locally. Be sure to secure its green wire to the center screw of the *wall outlet plate* or ground screw on the preamplifier chassis. If a longer power cord is needed, use a 3-wire cable of the type specified for air conditioners. Do not attempt to defeat the grounding lug of the ST70II's power cord. The Stereo 70 II can be turned on and off from the back panel switch, or this switch can be left in the "on" position, and the amplifier switched from one of the switched ac outlets on the associated preamplifier.

### Input

Signal input connections are via shielded cables to gold-plated phono jacks on the front panel, between the two LED pairs. Channel A is designated the left channel; B the right. *The amplifier requires an input load impedance source of less than 2,000 ohms.* The Stereo 70 II may thus be easily driven by virtually all modern control preamplifiers. Input sensitivity is 1.3 volts rms for maximum power output.

### Output

Select speaker wire output leads of sufficient size to preserve the outstanding capabilities of your amplifier. HEAVY GAUGE #16 lamp cord ("zip cord") is suitable for distances up to 20 feet with an 8 ohm load. Larger wire size should be used for longer distances -- #14 for 30 feet; #12 for 50 feet. #16 lamp cord is available from hardware stores; #14 and #12 twisted cable may be obtained from electrical supply houses. For a 4 ohm load, these maximum distances should be cut in half.

Connect the left speaker to the Channel A (LEFT) amplifier output terminals. Be sure to maintain similar wiring "sense" for each speaker, so that they will be connected *in phase*. Normally, the (-), common, or ground terminal of each speaker is connected to the **BLACK** amplifier terminal. Proper phase sense is easily maintained with lamp cord because one conductor is coded with a molded ridge on the outer insulation, or different color conductors are used.

Two speakers are connected in phase when maximum low frequency output is heard when they are driven from a monophonic source. Lowered output is observed when the connection to one of the speakers is reversed (out of phase, or reversed polarity).

The amplifier terminals are the finest gold-plated 30 amp rated binding posts. Each will accept single or double "banana plugs", spade lugs, or simple stranded wire. If stranded lamp cord is used, the wire ends should be carefully twisted together or solder "tinned" to avoid fraying. To connect the wire, unscrew the terminal cap until the vertical hole through the metal shaft is uncovered from below, push the wire end through the hole, and tighten the cap. (Note: Unlike transistorized solid-state amplifiers, the (+) terminal [may also be referred to as "hot" or color-coded "red"] should be connected to the **RED** amplifier terminal most closely matching the nominal impedance of your chosen speaker (typically "8 ohms;" nominal impedance is usually specified on the speaker). Dynaco suggests that you *not* operate the Stereo 70 II without speakers connected.

Make certain that no wire strands can touch other than the intended terminal. Double banana plugs (from radio supply houses) are, by far, the most convenient connectors, and are simply inserted into the open ends of the binding post terminals. (Note: Purists often avoid banana plugs, however, because of

---

---

their limited surface contact area.) Double banana plugs are particularly useful, however, if a second set of speakers is to be connected in parallel, as they plug "piggyback" into one another. *Caution: Never connect the red "hot" terminals together.*

**MONOPHONIC OPERATION.** The use of 1% gain resistors reduces channel gain differences minimizing the difficulties in paralleling channels for higher power. It is now feasible to parallel the two 16 ohm speaker taps to drive an 8 ohm load using a "y" adapter (available from Dynaco or a local electronic parts dealer) on the input jacks and achieve 70 watts monophonic power. To configure your ST70 II for 8 ohm monaural operation simply connect together the two red "16 ohm" binding posts with a short length hookup wire or speaker wire. Likewise, connect the two black "C" (common) binding posts. (Procedure is the same for 4 ohm rated speakers except you connect the two "8 ohm" binding posts instead of the 16 ohm.) Use of a "Bridging" technology phase inverter is an alternate approach for this but the parallel technique minimizes additional signal path and is less costly. The sonic difference is left to individual descretion.

### **CIRCUIT DESCRIPTION.**

Your ST70 II is an operational "Class A" push-pull design. Plate voltage for the tubes is taken from the power transformer, rectified by D1-D4, filtered by C1-C4 and L1. Negative bias voltage for the output tubes is obtained from PS, filtered by C5 and C6, adjusted through R6 and applied to the output tube grids through R22 and R23. The bias indicator circuit is powered by U1. The voltage to the input of VI is dropped by R47 and dependent upon the operating current of the bias indicator circuit. V1 provides 12.0 regulated volts. R4 and R10 divide this voltage to provide a 1.56 volt reference for Q1. The differential pair of Q1 and Q2 compare the voltage across R8 to the reference and create a current balance through the LED's proportional to the balance of voltage. The LED's are balanced when the reference and R8 voltages are equal. This represents 50 ma current through each output tube. Signal is passed through the bandwidth limiting network of C11, R12, C12 and R13 to the grid of V1-A. This high-gain pentode section singly provides most of the open-loop gain for the signal. The output of this stage is direct coupled to the cathodyne phase-inverter V1-B that "mirrors" the audio signal and capacitor couples the signals to the output tubes via C15 and C16. It is critical that R20 and R21 are matched to 1% to minimize distortion. The beam-power pentodes provide the final power gain necessary for impedance conversion by the output transformer and speaker drive. Distortion correction is provided from the 8 ohm tap via R26, R18 and R17 to the cathode of V1-A. C17 provides high frequency stability avoiding the delay inherent within the output transformer.

---

---

## CONTROLS

### Adjusting Tube Bias

Periodic bias adjustment is the “key” to continued top performance in a vacuum tube power amplifier. *No other user maintainance is required except for infrequent replacement of vacuum tubes.* Proper biasing maintains optimal power and minimum distortion as the characteristics of the power output tubes change with age. Output tube bias was always inconvenient, at best, with the original ST70 (requiring removal of the cover and availability of a volt-ohm meter).

The Series II ST70 makes this important periodic adjustment easier and far more accurate by using two red LED's [light emitting diodes] and a recessed front panel mounted screwdriver-adjustable trimpot for each channel. (Since this adjustment is made at the factory just prior to the unit being boxed, initial bias adjustment should require a modest adjustment.) The LED's provide continual monitoring of bias status during operation. *NOTE: It is normal to see the LED's momentarily unbalance during power line changes (i.e., when a heavy draw load switches on, such as furnace, air conditioner or when strong audio signals are being processed by the amplifier).*

**The bias current is CORRECTLY SET when both the “LO” and “HI” LED's are of equal brightness — on each of the two channels — at amplifier idle (no signal).**

*Allow the amplifier to run for approximately 5 minutes at idle (no signal feed). Insert a small Phillips #0 screwdriver in each of the two holes above and between the LED pairs, and turn the recessed potentiometer clockwise or counterclockwise until the brightness of each of two LED pairs is balanced to itself.* The amplifier should fully stabilize within 15 minutes. At that point you may need to fine adjust the trimming potentiometers. Additional adjustments should not be needed again for a period of weeks.

### CAUTIONS

**NOTE:** When your ST70 II is first powered, initially only one LED of each pair will light. **THIS IS NORMAL OPERATION.** After warmup (5 minutes) the LED brightness should come into balance without additional tweeking. (Dynaco's bias circuit is so precise that all that is really required is for the *all* LEDs to display *some* illumination, though for cosmetic reasons you'll likely want them balanced.)

The Stereo 70 II is ruggedly designed to withstand the rigors of many years of use, and it is fuse protected against the hazards of possible malfunction. Good operating practice will avoid the need to test the effectiveness of the fusing, however, for there is no such thing as absolute protection from abuse.

The combination of the ST70 II's potential power and the relative fragility of most high quality sound reproducers makes it imperative that you take care to avoid *such common faults as leaving the preamp volume control set too high on powerup of your ST70 II (it may take as long as 30 seconds warmup for your ST70 II to produce sound);* dropping a stylus (tone arm) onto the record; allowing the arm to skid across the record; flicking the stylus clean with your finger while the volume is up; and excessive use of tonal compensation by advancing bass and treble controls to extremes at high volume levels (a particular problem with the dynamic range inherent in much of today's digital source material). These are typical errors which generate heavy low frequency pulses capable of severely overdriving the speaker and/or amplifier before protective fuses can act.

Your ST70 II's power switch is located next to the right channel speaker terminals on the rear panel. The “on” position will either be denoted by the word “on” or the international symbol “|”. “Off” will be denoted by the word or the international symbol “O”.

**FUSES.** The ST70 II is protected by a 3 amp *slo-blo* type fuse. **NEVER REPLACE THIS FUSE WITH A FUSE OF HIGHER AMP RATING!** (A spare fuse is included with your amplifier.)

---

---

## IN CASE OF DIFFICULTY

Your Dynaco ST70 II has been designed to be as free from trouble as possible. However, a defective component can affect its performance or make it inoperative.

The tubes should light after a few seconds of warmup. If they do not, it is probable that there is no ac voltage getting into the amplifier, which indicates a possible blown fuse.

### No Sound Output

- If tubes are NOT lighted...
    1. Is your amplifier's ac cord properly connected to a powered outlet?
    2. Is the power switch "on"?
    3. Is there a blown fuse? (A spare 3A/slo-blo fuse is included with your amplifier.) First, turn the amplifier to the "off/O" position. Unscrew the fuseholder cap on rear panel; remove and examine fuse. If the fuse is replaced and immediately blows again, contact Dynaco service.
  
  - If tubes ARE lighted (but no sound)...
    1. Check your preamplifier to make sure proper "source" is selected. Also check to see if the "tape monitor" button has been mistakenly engaged.
    2. Check *all* connecting cables / speaker wire to make sure they originate and terminate properly. Also check for faulty cables by swapping cables.
  
  - Tubes ARE lighted with ONE CHANNEL operational...
    1. Check for defective cabling by swapping all wires (input and output) from the working channel to the non-working. If the problem now moves to the opposite channel the problem lies with one or more of your connectors. Attempt to isolate the trouble cable and replace it.
    2. Use the working channel for test purposes, and swap tubes from from the one channel to the other. If the problem now moves to the opposite channel the problem lies with one or more defective tubes. (Though all tubes are PRETESTED and matched at the factory, tubes may be damaged in shipment, or if the unit is dropped. For best results, replace only with pretested/ matched Dynaco tubes.) Adjust bias after any tube replacement.
  
  - One or more tubes is GLOWING BRIGHT RED...
    1. It is likely that the tube glowing red is faulty. You may swap tubes to easily confirm this. If the problem persists even when plugging the same tube into a different socket, replace the offending tube. If the problem remains confined to a particular socket, contact Dynaco to arrange service.
  
  - Hum and Noise...

The inherent hum and noise of a correctly operating ST70 II is rated below audibility. If hum and noise appear, it is necessary to determine whether they occur within the amplifier. Sometimes noise in the preamplifier is blamed on the amplifier. The simple test is to remove the cables from the input socket and see whether the same noise is present. If the noise is removed when the cable is unplugged, it is in the preceeding equipment which should then be checked. If not, it is probably in the amplifier. In the event that trouble shooting will not correct the problem, contact Dynaco.
-



---

## LIMITED WARRANTY

For 3 YEARS from the date of purchase (1 YEAR PARTS on tubes) Dynaco will repair for the original owner any defect in materials or workmanship that occurs in normal use, without charge for parts or labor.

Your responsibilities are to use the amplifier according to the instructions supplied, to provide transportation to the authorized Dynaco service representative who will perform warranty service, and to present proof of purchase in the form of your dated sales slip when requesting service.

Excluded from this warranty is damage that results from abuse, misuse, accidents, shipping, or repairs or modification by anyone other than an authorized Dynaco service representative. This warranty is void if the serial number has been removed or defaced.

This warranty gives you specific legal rights, and you may also have rights which vary from state to state.

If service is required, contact the dealer from whom you purchased the amplifier. If that is not possible, write Dynaco, 125 Cabot Court, Hauppauge, NY 11788, giving us:

Your name and address

The amplifier's serial number

When and where you purchased it  
(copy of sales slip)

Make and model of your amplifier

Description of the problem

Whether you have the original carton and fillers or need new ones

## DYNACO

A Division of Panor Corp.

125 Cabot Court  
Hauppauge, NY 11788

(516) 434-1200  
(516) 434-1457 FAX

---

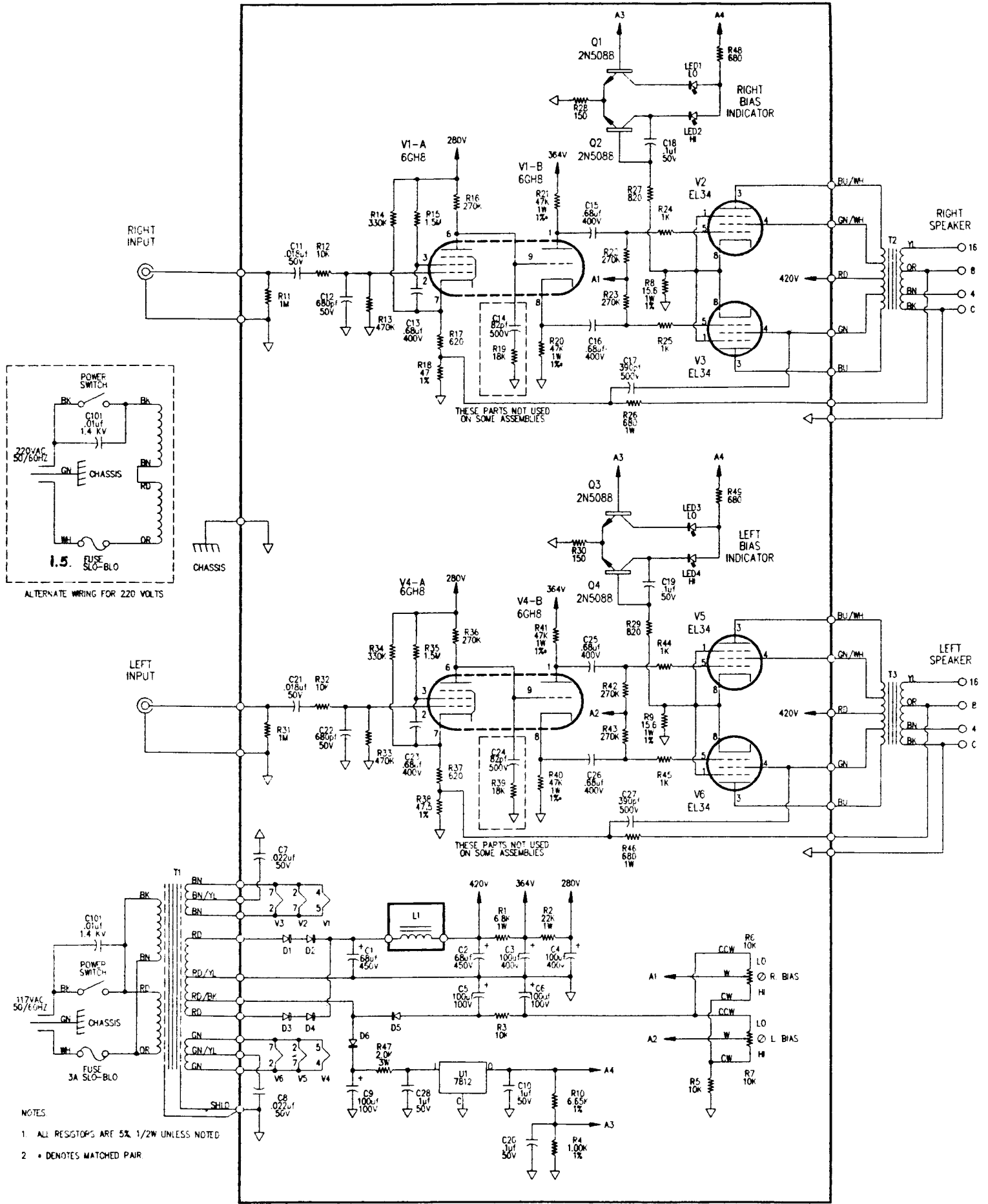

PRINTED CIRCUIT ASSEMBLY

- NOTES
1. ALL RESISTORS ARE 5% 1/2W UNLESS NOTED
  2. • DENOTES MATCHED PAIR

---

Output Paralleling your ST70 II for 70W mono operation:

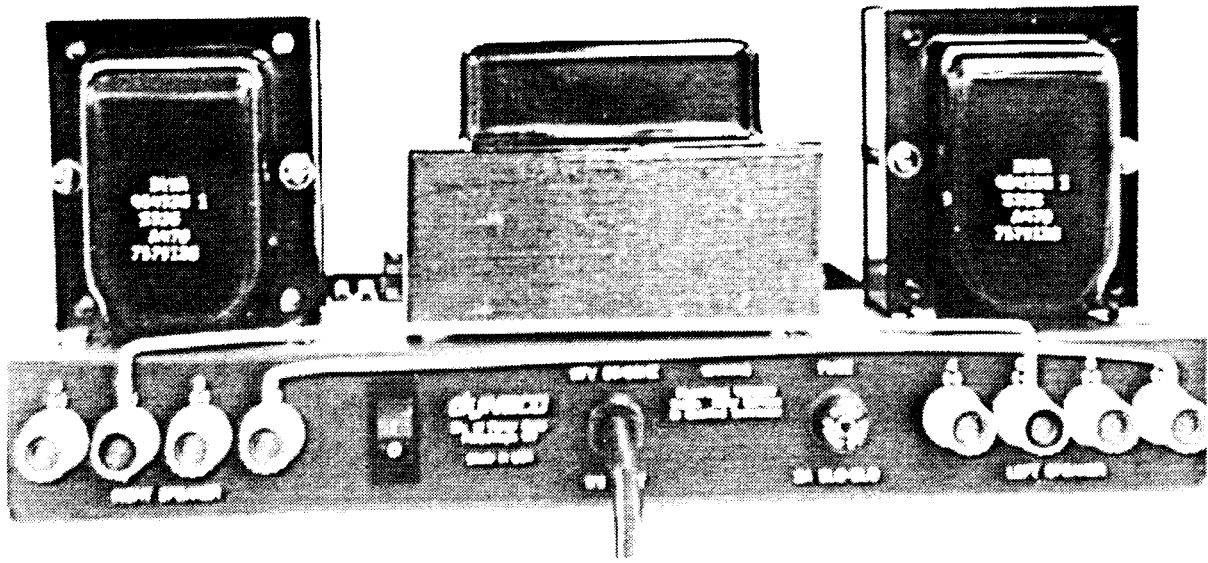

Using two lengths of 16-20 guage speaker or hookup wire

- Jumper connect the (2) "Common" BLACK terminals as shown.

THEN:

- For nominal 8 ohm load -- connect the (2) RED "16" (ohm) taps (as shown),

OR...

- For nominal 4 ohm load -- connect the (2) RED "8" (ohm) taps.

FINALLY:

- Connect the (+) wire of ONE speaker to one of the two jumpered RED terminals.
- Connect the (-) wire of ONE speaker to one of the two BLACK terminals.

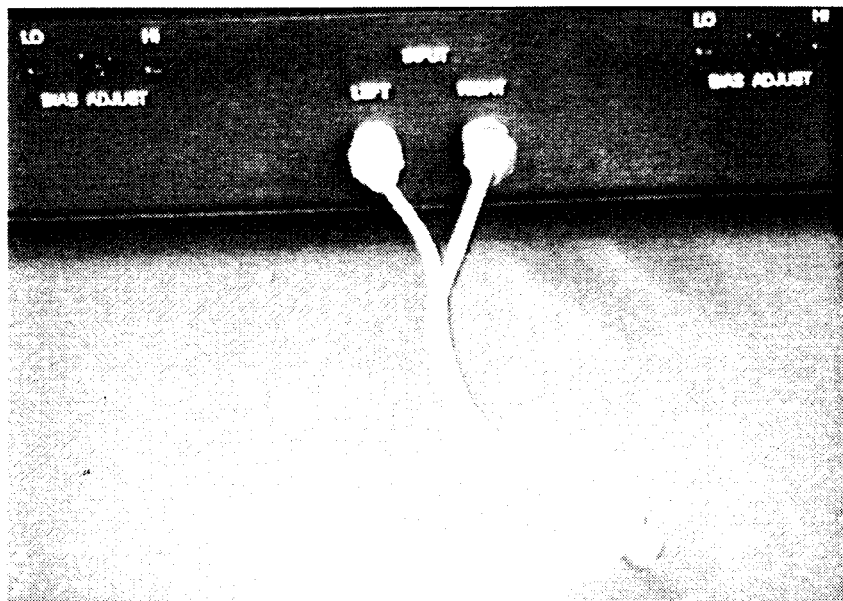

Use a commonly available "Y-adaptor" to combine input signals.

---

Bonus: Paralleling will actually *reduce* distortion by a factor of  $1 \div$  the square root of 2.

---

---

## **DYNACO REPLACEMENT PARTS & SERVICE**

DYNACO authorized parts and service for your ST70II amplifier is available directly from:

SCC  
185 N. Yale Ave.  
Columbus, OH 43222  
(614) 279-0368

**VINTAGE DYNACO PARTS.** In addition to stocking all parts for your new Dynaco ST70 Series II, an extensive inventory of parts is carried for older Dynaco electronics and loudspeakers. While many older parts have become unavailable, SCC endeavors to keep as many of the most popular parts on hand as possible. All parts are computer inventoried under their original 6-digit Dyna part number. **THE OPERATORS WHO ANSWER OUR ORDER LINES MUST HAVE THESE ORIGINAL PART NUMBERS TO ENTER YOUR ORDER INTO OUR SYSTEM.** (If you do not have the part number listing in your original manual, we will be happy to supply a photocopy of same provided you furnish us with a business size self-addressed stamped envelope specifying model number desired.) An extensive list of available parts is also available for \$2.00 to cover postage and handling.

We regret that **OUT-OF-WARRANTY SERVICE** on older Dynaco equipment is no longer available from SCC. The labor intensive (and thus costly) nature of dealing with poorly assembled/soldered kits, plus increasing parts limitations, has made it impossible for our company to effect repair at reasonable cost to the consumer. While it may not be practical for a service shop to heat and resolder every connection in an older kit-built Dyna, many individuals delight in the challenges of restoration. (Since Dyna components were inherently rugged, resoldering will sometimes be the only repair needed.) *Schematic and/or parts callout FREE provided self-addressed envelope [and model #] are enclosed.*

### **REPLACEMENT / SPARE ST-70 II TUBES**

For best results DYNACO strongly recommends using only its performance checked pretested vacuum tubes. *Dynaco routinely rejects up to 20% of the tubes other vendors sell as "first quality."* An extensive prescreening of each and every Dynaco tube is your assurance of realizing top performance and long life. *Each tube is guaranteed to perform properly in its intended application for ONE YEAR* (versus industry standard warranty of 90 days). **Orders for tubes may be paid for by personal check or money order. Please also include \$4.00 for shipping and handling.**

- |  |                          |
|--|--------------------------|
| • <b>EL34 / 6CA7 Output Tubes (matched pair)</b>     | <b>\$29.95 / pair</b>    |
| • <b>EL34 / 6CA7 Output Tubes (matched quad set)</b> | <b>\$59.90 / four</b>    |
| • <b>6GH8A Driver Tubes (each)</b>                   | <b>\$9.95 each</b>       |
| • <b>6GH8A (matched pair)</b>                        | <b>\$19.90 / pair</b>    |
| • <b>Complete Retube Set</b>                         | <b>\$79.00 / 6 tubes</b> |
| <br>   |                          |
| • <b>Y-Adapter for monophonic operation</b>          | <b>\$10.00 each</b>      |
-