

Owner's Manual

# Model X-14

Multitracker

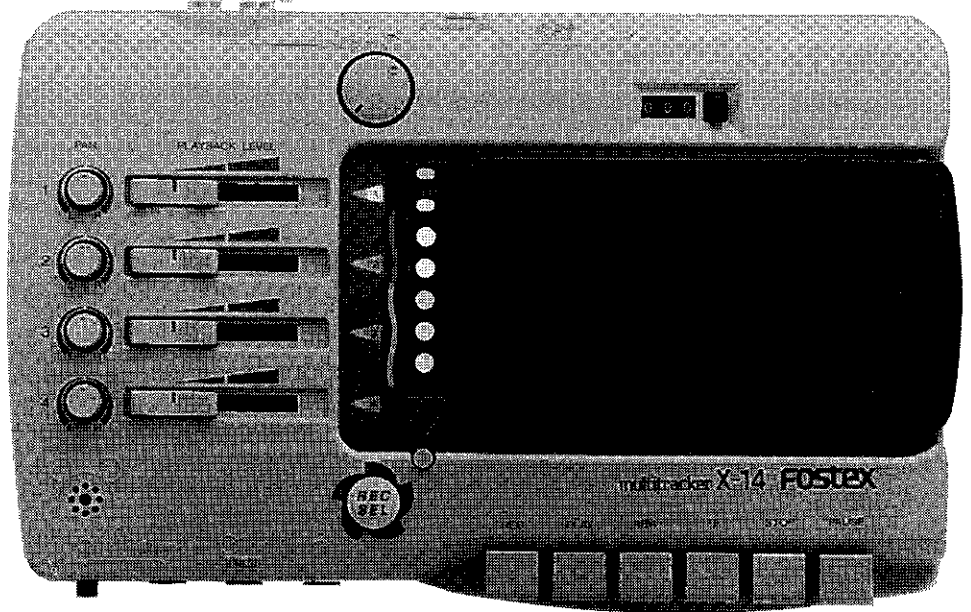

**Fostex**



**CAUTION**

RISK OF ELECTRIC SHOCK  
DO NOT OPEN



CAUTION: TO REDUCE THE RISK OF ELECTRIC SHOCK,  
DO NOT REMOVE COVER (OR BACK).  
NO USER - SERVICEABLE PARTS INSIDE.  
REFER SERVICING TO QUALIFIED SERVICE PERSONNEL.

**CAUTION:**

TO PREVENT ELECTRIC SHOCK, MATCH WIDE BLADE  
OF PLUG TO WIDE SLOT, FULLY INSERT.

**ATTENTION:**

POUR ÉVITER LES CHOCs ÉLECTRIQUES,  
INTRODUIRE LA LAME LA PLUS LARGE DE LA FICHE  
DANS LA BORNE CORRESPONDANTE DE LA PRISE  
ET POUSSER JUSQU' AU FOND.



The lightning flash with arrowhead symbol, within an equilateral triangle, is intended to alert the user to the presence of uninsulated "dangerous voltage" within the product's enclosure that may be of sufficient magnitude to constitute a risk of electric shock to persons.



The exclamation point within an equilateral triangle is intended to alert the user to the presence of important operating and maintenance (servicing) instructions in the literature accompanying the appliance.

## "WARNING"

"TO REDUCE THE RISK OF FIRE OR ELECTRIC SHOCK, DO NOT EXPOSE THIS APPLIANCE TO RAIN OR MOISTURE."

## SAFETY INSTRUCTIONS

1. Read Instructions - All the safety and operating instructions should be read before the appliance is operated.
2. Retain Instructions - The safety and operating instructions should be retained for future reference.
3. Heed Warnings - All warnings on the appliance and in the operating instructions should be adhered to.
4. Follow Instructions - All operating and use instructions should be followed.
5. Water and Moisture - The appliance should not be used near water - for example, near a bathtub, washbowl, kitchen sink, laundry tub, in a wet basement, or near a swimming pool, and the like.
6. Carts and Stands - The appliance should be used only with a cart or stand that is recommended by the manufacturer.
7. Wall or Ceiling Mounting - The appliance should be mounted to a wall or ceiling only as recommended by the manufacturer.
8. Ventilation - The appliance should be situated so that its location or position does not interfere with its proper ventilation. For example, the appliance should not be situated on a bed, sofa, rug, or similar surface that may block the ventilation openings; or, placed in a built-in installation, such as a bookcase or cabinet that may impede the flow of air through the ventilation openings.
9. Heat - The appliance should be situated away from heat sources such as radiators, heat registers, stoves, or other appliances (including amplifiers) that produce heat.
10. Power Sources - The appliance should be connected to a power supply only of the type described in the operating instructions or as marked on the appliance.
11. Grounding or Polarization - The precautions that should be taken so that the grounding or polarization means of an appliance is not defeated.
12. Power Cord Protection - Power supply cords should be routed so that they are not likely to be walked on or pinched by items placed upon or against them, paying particular attention to cords at plugs, convenience receptacles, and the point where they exit from the appliance.
13. Cleaning - The appliance should be cleaned only as recommended by the manufacturer.
14. Nonuse Periods - The power cord of the appliance should be unplugged from the outlet when left unused for a long period of time.
15. Object and Liquid Entry - Care should be taken so that objects do not fall and liquids are not spilled into the enclosure through openings.
16. Damage Requiring Service - The appliance should be serviced by qualified service personnel when:
  - A. The power supply cord or the plug has been damaged; or
  - B. Objects have fallen, or liquid has been spilled into the appliance; or
  - C. The appliance has been exposed to rain; or
  - D. The appliance does not appear to operate normally or exhibits a marked change in performance; or
  - E. The appliance has been dropped, or the enclosure damaged.
17. Servicing - The user should not attempt to service the appliance beyond that described in the operating instructions. All other servicing should be referred to qualified service personnel.



An appliance and cart combination should be moved with care. Quick stops, excessive force, and uneven surfaces may cause the appliance and cart combination to overturn.

Thank you very much for purchasing the Fostex Model X-14.

The Model X-14 is a four-track, four-channel multitracker with an internal condenser microphone, as well as two inputs for different types of sound sources (for an external microphone and a line input, such as a keyboard, guitar, etc.).

The Model X-14 features "hands-free recording" that makes it easier to record thanks to the internal microphone, and an "E-Z Rec function" that enables you to record without the nuisance of setting switches. These user-friendly, simple features have made it possible for even first-time users of a multitracker to perform multitrack recording quickly and easily.

Please read this User's Guide thoroughly before using the Model X-14 to make the best use of the unit for a long period of time.

## Contents

Precautions.....	2
Cautions for Using the X-14.....	4
Before Using the X-14.....	4
Names and Functions.....	5
Basic Operation (Recording).....	8
1. Recording Using a internal microphone.....	8
2. Recording with an external microphone.....	10
3. Recording the electric guitar or keyboard.....	10
Basic operation(Playback).....	11
Advanced Operation (Multitrack recording).....	12
1. Overdubbing.....	12
2. Mixdown.....	15
Troubleshooting.....	17
Maintenance.....	17
Specifications.....	18
Block diagram.....	19

## Precautions (please read before use)

### Power supply

- \* When unplugging the AC adaptor from the outlet, be sure to grasp the adaptor. Attempting to unplug it by pulling on the AC cable may damage the wiring.
- \* It is hazardous to use a power cable which has been cut or frayed. If the power cable becomes damaged, immediately stop using it, and have it repaired.
- \* Do not plug in or unplug the AC adaptor when your hands are wet. Doing so may result in dangerous electric shock.
- \* Do not open the unit or touch the parts inside. Doing so may result in dangerous electric shock, and may damage the unit.

- \* Do not allow water or other liquids, flammable materials, or metal objects such as pins to get inside the unit.

These things may cause electrical shock, and may damage the unit.

If the unit should become wet, unplug the AC adaptor from the AC outlet, and contact your authorized service station.

- \* When turning the power on, turn this unit on before turning on other equipment connected to this unit. Doing so will avoid possible damage to the other equipment. Also, when connecting or disconnecting cables to or from the unit's input or output jacks, make sure that the OUT LINE volume is turned down to a level of 0.

- \* When the AC adaptor is connected to an AC outlet, it will continue to draw small amounts of power even if the switch is set turned off (STANDBY). If you will not be using the unit for an extended length of time, be sure to unplug the AC adaptor from the outlet.

### Location

- \* Avoid using the unit in the following types of location.
  - \* Locations of extreme low or high temperatures, or extreme changes in temperature.
  - \* Locations with excessive moisture or dust.
  - \* Locations where direct sunlight falls for an extended time, or near a stove or other source of heat.
  - \* Locations where electrical voltage is not steady.
  - \* Unstable locations or where there is heavy vibration.
  - \* Near strong magnetic fields (on top of a television or speaker).

## Cautions for Using the X-14

Heed the cautions below when you are using the X-14. Otherwise, howling or oscillation noise could impair your hearing ability.

1. Do not turn up the LINE OUT controls of the monitor speaker and the X-14 when powered monitor speakers, such as FOSTEX Model 6301B, are connected to the LINE OUT jack and the internal microphone ON/OFF switch is turned on. Otherwise, a feedback loop will be generated and cause howling, which will be output from the connected monitor speakers or headphones and may impair your hearing ability.
2. Do not remove the plug connected to the Microphone Input of the Guitar/Keyboard Input jack when the Internal Microphone ON/OFF switch is turned on and the LINE OUT knob is turned up. Otherwise, as described in Item 1, feedback howl may impair your hearing ability.
3. Do not connect the signal output from the LINE OUT jack to the Microphone Input or the Guitar/Keyboard Input jack. (For example, do not connect the LINE OUT jack directly to the Input jack.) Otherwise, a feedback loop will be generated and turning up the LINE OUT knob will cause oscillation, which may impair your hearing ability.

## Before Using the X-14

### <The difference between multitracker recording and cassette deck recording>

A jam box and a stereo cassette deck allow for stereo recording on side A and side B of a cassette tape. As shown in the figure below, a cassette tape is divided into four tracks: two for side A, and two for side B. On the other hand, a multitracker, such as the X-14, uses all four tracks on the same side to record songs or instruments. (That is, a tape becomes one-sided, not two-sided (A&B)). If you record something on the multitracker and play the tape on a jam box or cassette deck, Tracks 1 and 2 will play normally, but when you try to play the other side of tape, Tracks 3 and 4 will play in reverse.

Jam box/Cassette deck

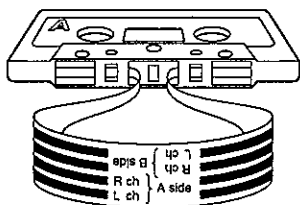

Multitracker, such as X-14

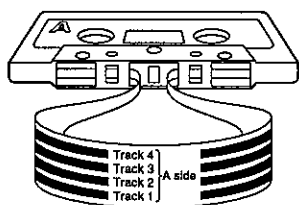

### Hint!

You can perform multitrack recording using a tape that was recorded on a jam box or a cassette deck. Refer to page 16 for more details.

### <Handling cassette tapes>

#### Cassette tape suitable for recording:

The X-14 is designed to provide the best performance if you use a high-position cassette tape (TYPE II, HIGH). We recommend that you use these types or equivalent tapes to perform multitrack recording on the X-14. C-120 tapes (60 minutes each side) are thin and not suitable for repeated recording or playback. Use C-90 or shorter tapes for stable multitrack performance.

#### Using write-protection tabs:

On the spine of a cassette tape are write-protection tabs that are used to prevent any recorded data from being erased accidentally. You may want to break the tab for side A and side B of a cassette tape that you have already recorded, since the X-14 uses all four tracks at the same time. If you later wish to record data on a tape with broken tabs, apply a piece of scotch tape to cover the tab hole.

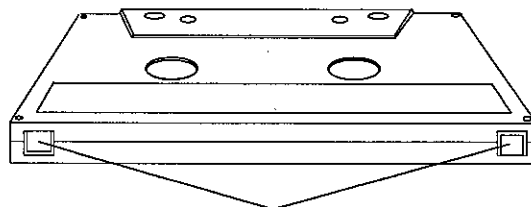

Write-protection tabs

## Names and Functions

This section explains the names and functions of the X-14, such as switches, controls, and I/O jacks. Read this section so that you will understand the functions of the switches and controls.

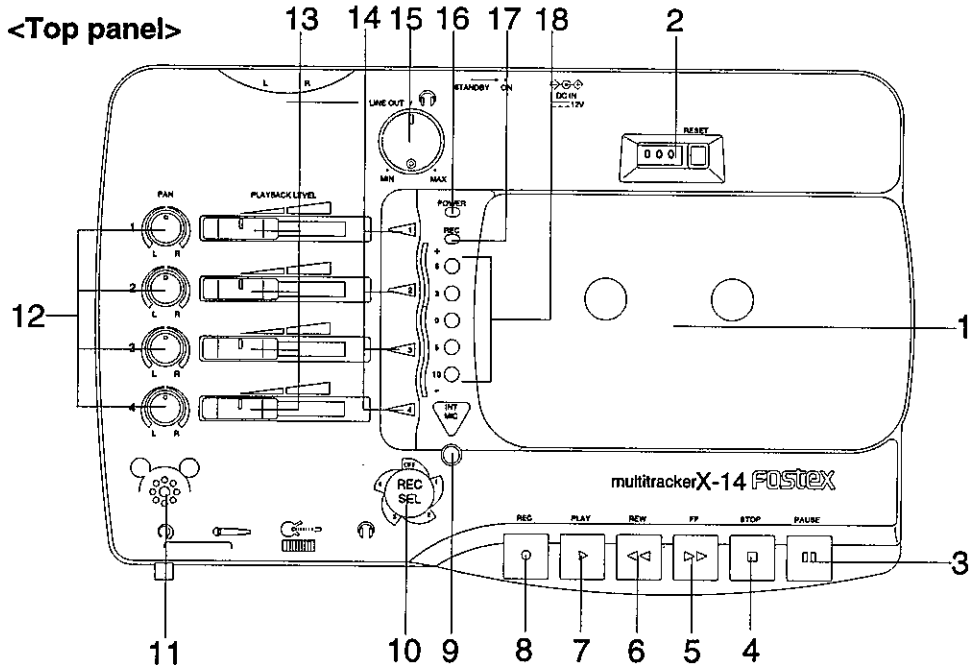

### 1. Cassette lid / Cassette tray

Insert a cassette tape here.

### 2. Counter / Reset button [RESET]

The counter indicates the tape count. Pressing the RESET button will reset the counter to [0000].

### 3. Pause button [PAUSE]

Press this button to stop playback or recording temporarily. To resume playback or recording, press this button again.

### 4. Stop button [STOP]

Press this button to stop tape transport.

### 5. Fast Forward button [FF]

Press this button to fast forward a tape.

### 6. Rewind button [REW]

Press this button to rewind a tape.

### 7. Play button [PLAY]

Press the button to play back a tape. When you press the REC button [8], this button will be automatically pressed and the unit will enter recording mode.

### 8. Record button [REC]

Press this button after you select a track using the REC SEL switch [10].

The PLAY button will be automatically pressed, and the unit will enter recording mode. (Note that this button is disabled if the cassette tape in the tray has a broken write-protection tab.) If the REC SEL switch [10] is set to [OFF], pressing this button will not enable recording, and the unit will play back a tape.

### 9. Internal Microphone ON/OFF switch [INT MIC]

Press this switch ON to record with the internal microphone. (The INT MIC LED will light up.)

ON,  OFF Note the following caution:



Even if this switch is turned on, an external sound source (such as an external microphone or keyboard) connected to the input jack will have priority. Do not connect any sound source to the input jack if you are using the internal microphone.

**10. Record Track Select button [REC SEL]**

This button enables you to select a recording track. You can select one recording track at a time. Pressing this button repeatedly will cycle the selection: [OFF] -> [Track 1] -> [Track 2] -> [Track 3] -> [Track 4] -> [OFF]. (The selected track's LED will light up in red. If you select [OFF], no track will be recorded.)

**11. Internal microphone**

Turn the Internal Microphone ON/OFF switch [9] ON to use the internal microphone. This microphone uses a condenser-type microphone with an ALC (Auto Level Control) function.

**12. Playback Panpot knobs [PAN]**

These knobs enable you to adjust the stereo image of the playback sound of each track.

**13. Playback Level faders [PLAYBACK LEVEL]**

These faders enable you to adjust the playback level of each track.

**14. Record Track indicator**

The indicator of the recording track by the [REC SEL] button will light up in red, and the corresponding track will be available for recording.

**15. Line Out / Headphone Level knob [LINE OUT]**

This knob enables you to adjust the output level at the LINE OUT L, R jack [25] and the PHONES jack [22].

**16. Power indicator [POWER]**

This indicator will light up in green when you turn on the power switch [24].

**17. Record indicator [REC]**

This indicator will light up in red in recording mode (or recording pause mode).

*"Recording mode" is the status in which one of the tracks has been selected by the REC SEL button (the corresponding track indicator is lit), the REC button has been pressed, and recording is in progress.*

*"Recording pause mode" is the status in which you have pressed the PAUSE button in recording mode, and tape transport is stopped (recording stand-by mode).*

**18. Level meter**

This meter indicates the input level.

<Front panel>

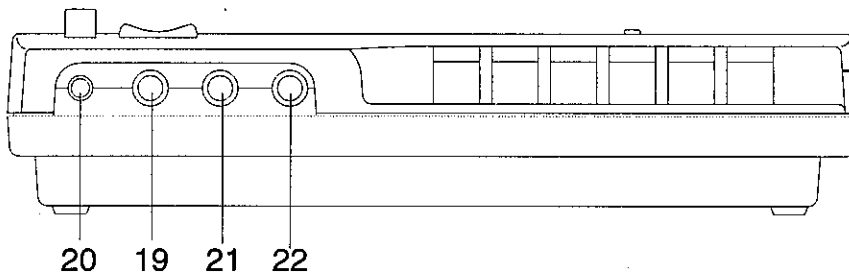

**19. Microphone Input jack (phone jack)**

Connect an external microphone here. You can fine-adjust the input level by using the Trim knob [20] located next to this jack. Even if the Internal Microphone ON/OFF switch [9] has been turned on, an external microphone connected here will have priority, and the internal microphone will be disabled. However, if another sound source is connected to the Guitar / Keyboard Input jack [21], that sound source will have priority, and the internal and external microphones will be disabled.

**20. Trim knob**

Use this knob to adjust the input level (in the range between -50dBV and -30dBV), depending on the output level of the connected external microphone.

**21. Guitar / Keyboard Input jack (Phone jack)**

Connect a line output instrument, such as a guitar or a keyboard, here. The sound source connected to this jack will have priority if the Internal Microphone ON/OFF switch [9] is turned on, or if an external microphone is connected to the Microphone Input jack [19]. (The internal and external microphones will be disabled.)

**22. Headphone jack** (Stereo Phone jack)

Connect monitoring headphones here.

You can adjust the headphone volume using the LINE OUT knob [15].

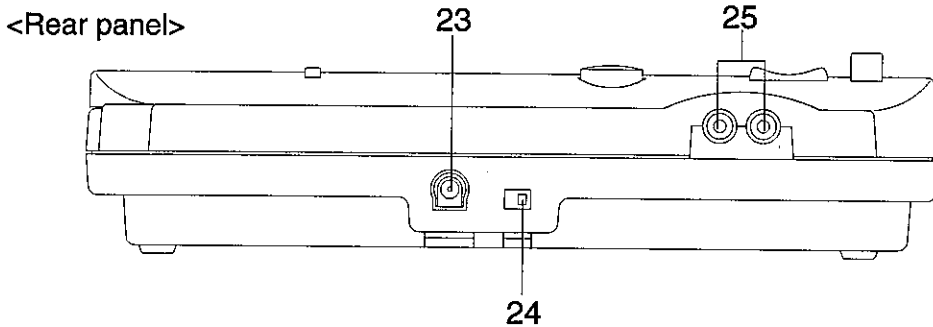

**23. AC Adapter connector [DC IN]**

Connect the AC adapter included in the package.

**24. Power switch**

Use this switch to turn the power on/off (STANDBY) to the X-14.

**25. LINE OUT jack** (RCA Pin jack)

This jack outputs a signal adjusted by the LINE OUT knob [15]. Connect this jack to the input jack of a cassette deck for mixdown.



When the AC adapter is plugged into an AC outlet, a very small current flows in the unit even if you turn off (STANDBY) the power switch.

If you know you will not use the X-14 for a long period of time, remove the AC adapter from the AC outlet. Leaving the AC adapter plugged into the AC outlet may cause a fire.



Be sure to use the included AC adapter or an equivalent model. Using an AC adapter with a different rated voltage or a different plug polarity may cause a fire or damage to the product.

The following figure indicates that the output voltage of the AC adapter is DC (direct current) 12V (volt), that the plug polarity is + (positive) in the center and - (negative) outside. Be sure to use an AC adapter that complies with this indication.

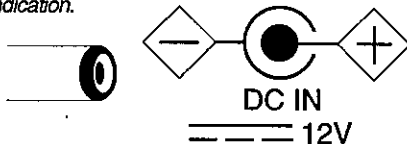

The X-14 uses the following connection plugs:

**Phone plug (monaural type)**

Use this plug to connect to the Microphone or Guitar / Keyboard Input jack on the front panel.

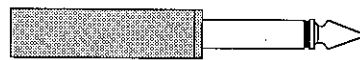

**Stereo phone plug (stereo type)**

Use this plug to connect to the Headphone jack.

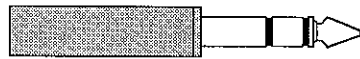

**RCA pin jack (monaural type)**

Use this plug to connect to the LINE OUT L, R jacks on the rear panel.



## Basic Operation [Recording]

Let's do some basic recording using the X-14.

This section explains the following procedures: "Recording with the internal microphone," "Recording with an external microphone," and "Recording an electric guitar or keyboard". You should be able to learn these procedures very easily since there are no complicated switch operations involved.

### 1. Recording with the internal microphone

The X-14's internal microphone enables you to record as if you were using a jam box. Follow the procedure below:

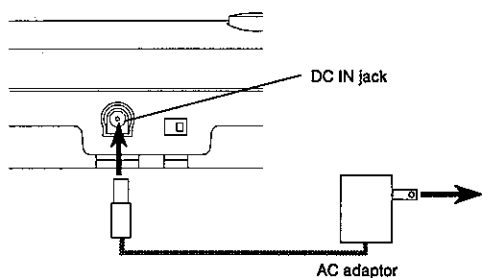

1. Connect the AC adaptor jack to the X-14's DC IN connector, and connect the power plug to the AC outlet.



*Do not handle the AC adaptor with wet hands. Otherwise, you may receive an electrical shock.*

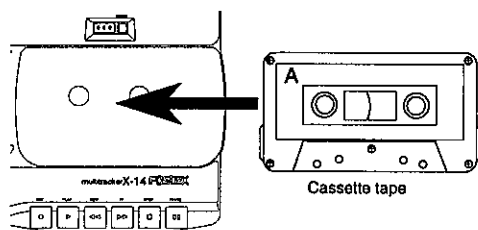

2. Open the cassette lid and insert a recording tape into the cassette tray.

When you use a used tape, make sure that the write-protection tabs on the spine of the tape are not broken. If any of them are broken, cover a tab hole with a piece of scotch tape.

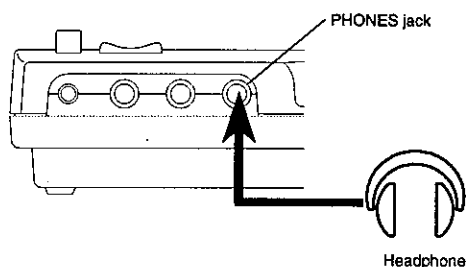

3. Connect monitoring headphones to the PHONES jack.

4. Turn on the power switch.

The POWER indicator will light up in red.

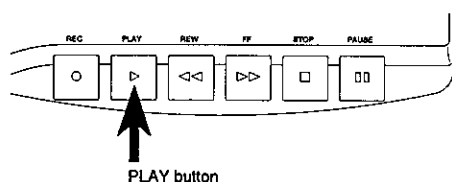

5. Press the PLAY button to transport the tape for a few seconds.

This should be performed in order to wind the leader part at the beginning of the cassette tape. If a used tape is not rewound completely, press the REW button to rewind the tape to the beginning and perform Step 5.



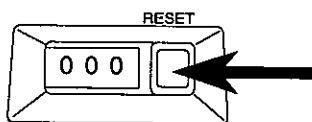

6. When the leader part is rewound, press the RESET button to set the counter to [000].

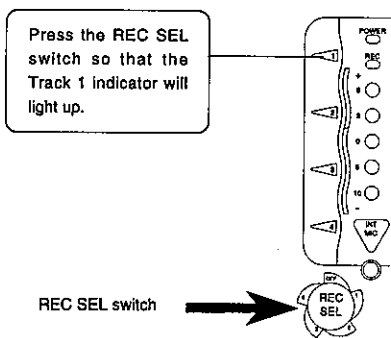

7. Select a recording track.

Press the REC SEL repeatedly until the desired track's indicator lights up. (In this example, let's select Track 1.) Pressing the REC SEL switch repeatedly will cycle the track selection as follows: [OFF] -> [1] -> [2] -> [3] -> [4] -> [OFF]. Repeatedly press the REC SEL switch until the [1] indicator lights up.

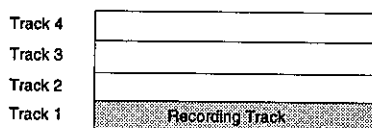

If you wish to record on another track, press the REC SEL switch to select the desired track.

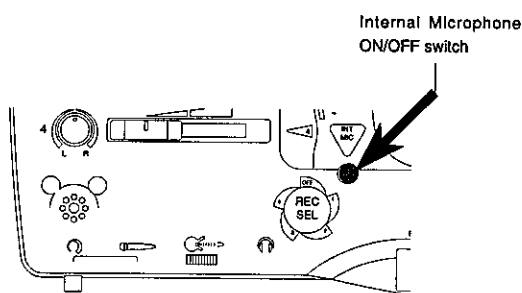

8. Turn on the Internal Microphone ON/OFF switch.

The INT MIC indicator will light up and the internal microphone will be enabled.



When using the internal microphone, do not connect any sound source to the input jacks (Mic or Guitar / Keyboard) on the front panel.

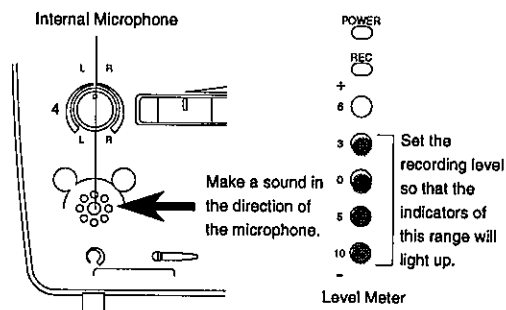

9. Sing or make a sound in the direction of the internal microphone.

The level meter will flash.

There is no control on the X-14 to adjust the recording level. To obtain the optimum recording level, adjust the volume level of the sound source or the distance between the microphone and the sound source.



Make sure that the level meter will not read too hot (that the +6 LED will not flash too frequently). Otherwise, the recorded sound may be distorted.

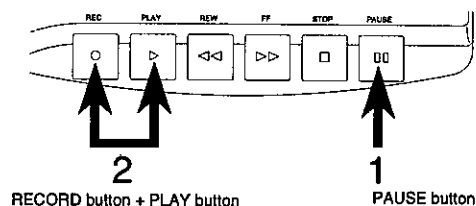

10. Recording stand-by

Press the PAUSE button, then press the RECORD button. (At this time, the PLAY button will be automatically pressed.)

The tape remains stopped, and the unit enters recording pause mode.

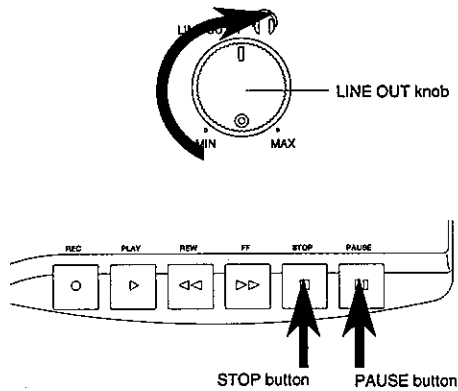

11. When you turn the **LINE OUT** knob clockwise, the headphone volume level will increase gradually.



*When you are monitoring the sound through the headphones for a long period of time, do not set the level too high. Otherwise, your hearing ability may be impaired.*

12. When an appropriate level is set, release the **PAUSE** button (by pressing it again) to start recording.

To stop recording temporarily, press the **PAUSE** button. To cancel or finish recording, press the **STOP** button, then the **PAUSE** button.

## 2. Recording with an external microphone

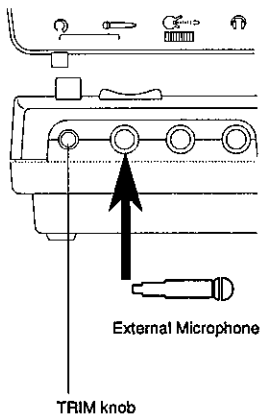

*Set the Internal Microphone ON/OFF switch to [OFF] and do not connect any sound source to the Guitar / Keyboard Input jack.*

- \* Connect a microphone to the **Microphone Input** jack on the front panel. (See the label printed on the panel.)

Follow the recording procedure described in "Recording with the internal microphone" to select and record a track. Use the Trim knob to adjust the input level, according to the output level of the connected microphone.

## 3. Recording the electric guitar or keyboard

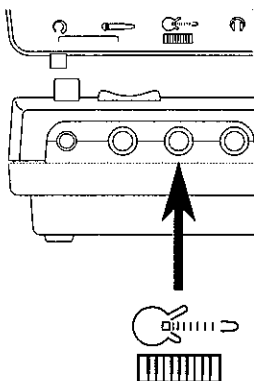

Line out sound sources, such as an electric guitar and keyboard



*Set the Internal Microphone On/Off switch to [OFF].*

- \* Connect the electric guitar or keyboard to the **Guitar / Keyboard Input** jack. (See the label on the panel.)

Follow the recording procedure described in "Recording with the internal microphone" to select and record a track. Adjust the recording level on the connected sound source.

**<Notes on recording>**



To obtain the optimum microphone (internal/external) recording level so that the level meter will not read too hot, adjust the volume level of the sound source or the distance between the microphone and the sound source. For recording the electric guitar or keyboard, adjust the output volume of the instrument to obtain the optimum level.



You can record one sound source at a time: either the internal microphone, external microphone, or guitar / keyboard. You cannot record multiple sound sources simultaneously, such as the combination of the internal microphone and a guitar. If you wish to record multiple sound sources simultaneously, use another Fostex mini mixer MNO4, MNO6, MN12 along with the X-14.

# Basic Operation [Playback]

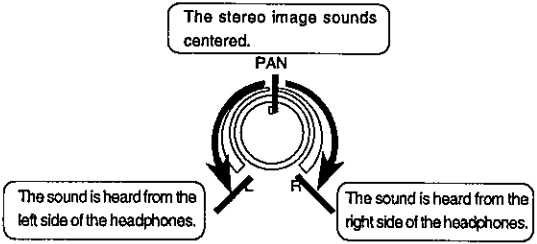
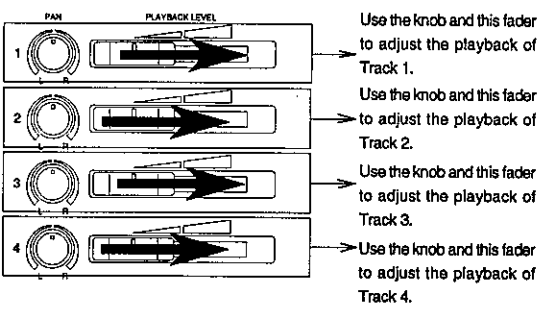
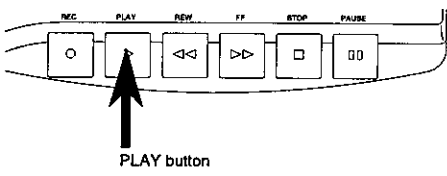
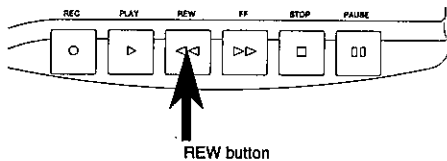

Now that you have recorded the sound on the desired track, you can play back the recorded track.



Set the Internal Microphone On/Off switch and the REC SEL switch to OFF.

1. Press the REW button to rewind the tape to the beginning (counter [000]).
2. Press the PLAY button to start playing back the tape from the [000] position.
3. Gradually raise the Playback Level fader that corresponds to the playback track, and use the Playback PAN knob to adjust the balance of the sound. (See the figure on the left.)

To listen to the sound through the headphones, turn the LINE OUT knob clockwise gradually up to an appropriate level.



When you are monitoring the sound through the headphones for a long period of time, do not set the level too high. Otherwise, your hearing may be damaged.

When you are playing a tape recorded on a jam box or cassette deck, use the Playback fader for Tracks 1 and 2, and the Playback PAN knob to adjust the volume and the balance, regardless of which side (A or B) you are playing.

# Advanced Operation [Multitrack Recording]

By now you have mastered recording and playing back on the X-14.

In this section, let's try "multitrack recording," which is the main feature of a multitracker.

This section explains "mixdown," which enables you to mix four recorded tracks and copy (dub) to a master recorder (such as a stereo cassette deck).

## 1. Overdubbing

Overdubbing is a recording technique used to record a performance to other track(s) while listening (monitoring) to previously-recorded track(s).

For example, you might record a rhythm section (such as a drum machine) in Track 1 by following the basic recording procedure, then record an electric bass on Track 2 while listening to the recorded rhythm.

In the same way, you record performances on all four tracks one by one.

This section uses an example in which Track 1 has the drum machine already recorded. (Follow the recording steps described in the Basic Operation chapter and use the drum machine instead of the electric guitar.)

We are going to overdub the electric bass on Track 2, the keyboard on Track 3, and vocal on Track 4.

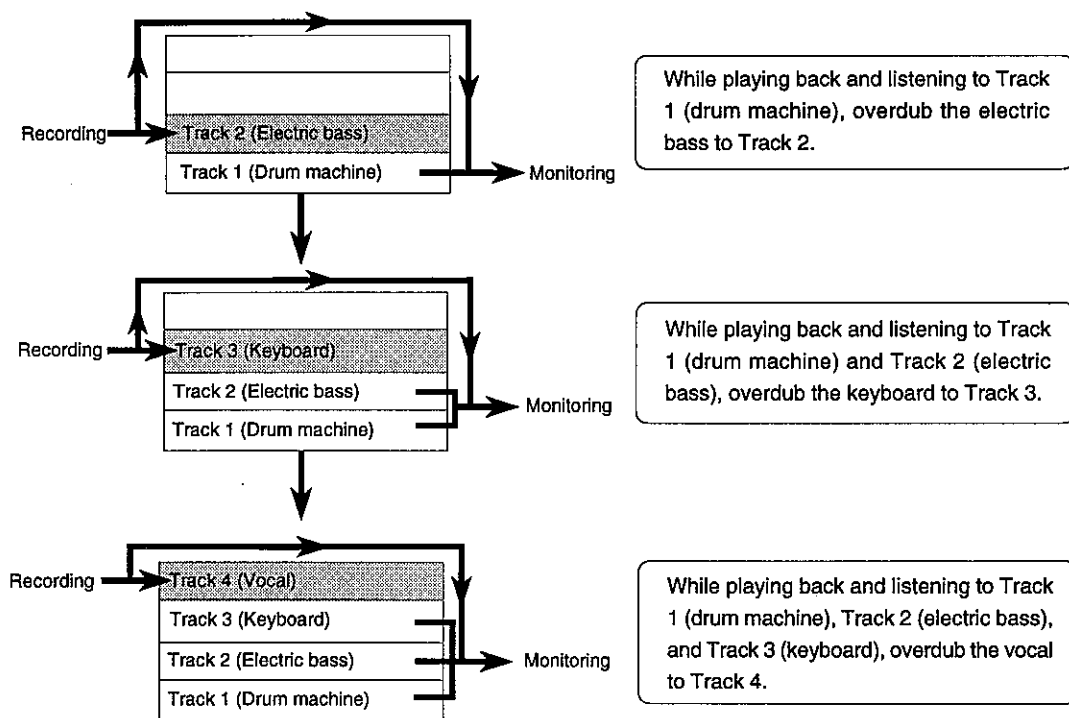

**Overdubbing the electric bass to Track 2 while listening to Track 1 (drum machine)**

Before you start overdubbing, practice your bass performance while monitoring the drum machine recording in Track 1 through the headphones.

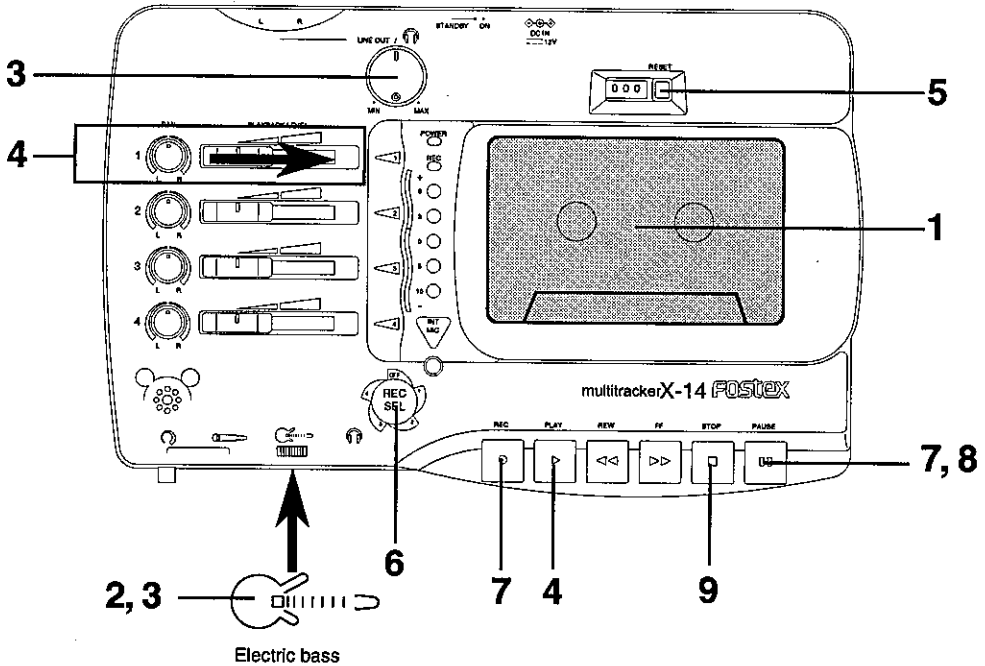

**1. Insert the tape on which the drum machine has already been recorded, and rewind the tape to the recording start position [000].**

**2. Connect the electric bass to the Guitar/ Keyboard Input jack.**

Do not connect the bass to the Microphone Input jack by mistake.

**3. Adjust the recording level of the electric bass.**  
Play the electric bass to check to see how the level meter is flashing. (Use the output volume on the bass so that the level is not too high.) Use the LINE OUT knob to adjust the headphone volume to an appropriate level.

**4. After you set the recording level, play back the tape from the [000] point and rehearse your bass accompanying the drum machine recording on Track 1.**

Use the Playback fader 1 and the Playback PAN knob 1 to adjust the monitoring level and balance of Track 1 (drum machine).

**5. When you finishing the rehearsal, rewind the tape to the [000] point.**

**6. Press the REC SEL button repeatedly until the Track 2 indicator lights up.**

**7. Press the PAUSE button, the press the REC button.**  
The X-14 will enter recording pause mode.

**8. Press the PAUSE button again to cancel recording pause mode and start recording.**  
Start playing and overdubbing the electric bass on Track 2, accompanying the drum machine on Track 1, while watching the recording level.

**9. When you finish recording, press the STOP button or the PAUSE button to stop the tape.**

If you have pressed the PAUSE button, press the STOP button to release the REC button and the PLAY button, then press the PAUSE button again.

The following table indicates the switch and knob settings used for overdubbing to Tracks 3 and 4. Refer to this table and to the steps described on the previous page to overdub the keyboard to Track 3 and the vocal to Track 4.

	Sound source	REC SEL button	Playback level fader	Playback PAN knob
<b>Overdubbing the keyboard to Track 3</b>	Connect the output of the keyboard to the Guitar/Keyboard Input jack.	Turn on the Track 3 indicator.	Use the Playback level fader 1 to adjust the Track 1 playback level, and use the Playback level fader 2 to adjust the Track 2 playback level.	Adjust the playback monitoring level. (Refer to the following section, "Using the Playback PAN knob.")
<b>Overdubbing the vocal to Track 4</b>	If you use the internal microphone, turn on the Internal Microphone ON/OFF switch. If you use an external microphone, connect the microphone to the Microphone Input jack.	Turn on the Track 4 indicator.	Use the Playback level fader 1 to adjust the Track 1 playback level, use the Playback level fader 2 to adjust the Track 2 playback level, and use the Playback level fader 3 to adjust the Track 3 playback level.	Adjust the playback monitoring level. (Refer to the following section, "Using the Playback PAN knob.")

**<Using the Playback PAN knob>**

When you are monitoring the recording sound and playback sound simultaneously, refer to the table below for the relationship between the position of the PAN knob and the sound balance. Adjust the balance according to your needs. (The recording sound will be always positioned in the center.)

Playback PAN knob position	Monitoring sound position
Center	Both playback sound and recording sound will be centered.
Hard R	The playback sound will be positioned on the right and the recording sound will be centered.
Hard L	The playback sound will be positioned on the left and the recording sound will be centered.

## 2. Mixdown

Mixdown is a technique that enables you to adjust the volume balance of the overdubbed Tracks 1-4, combine them to two channels, and dub (copy) to a master recorder. Refer to the diagram below:

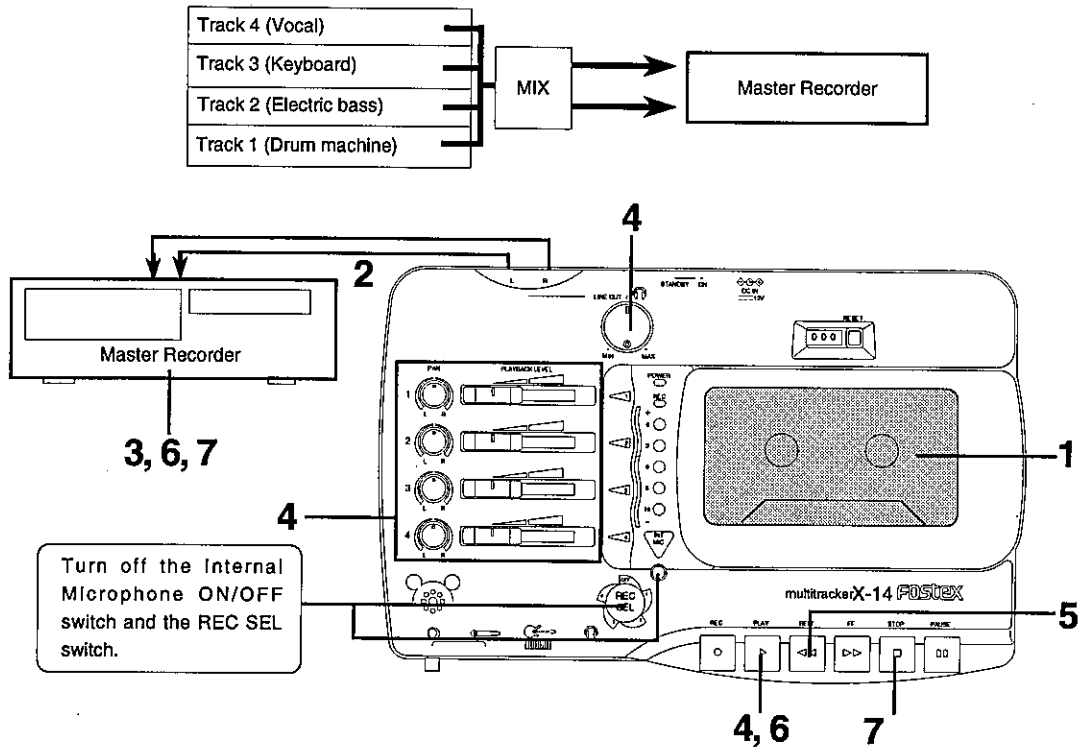

1. Insert a tape with Tracks 1-4 already recorded into the cassette tray, and rewind the tape up to the playback start point (reset the counter to [000]).
2. Connect the input jack of a master recorder, such as a cassette deck, and the LINE OUT (L, R) jacks. Insert a recording tape in the master recorder and locate the point on the tape at which you wish to start copying.
3. Set the master recorder to recording stand-by mode. (That is, press the PAUSE button so that the level meter will respond, then set the recorder in record pause mode.)  
The method for setting the recorder in record stand-by mode will vary depending on the recorder you are using. Refer to the instruction manual of the master recorder for more information.
4. Adjust the output level and balance (pan position) of Tracks, then adjust the input level on the master recorder.
5. After finishing the level adjustments, rewind the tape to the [000] point.
6. Now you can start mixdown.  
First start recording on the master recorder, then press the PLAY button on the X-14 to start playback.
7. After mixdown is complete, stop the X-14 and the master recorder.

### Using a tape recorded on a jam box or cassette deck

You can record your favorite music on a jam box or cassette deck and overdub your performance or vocal, accompanying your musician's performance to make your own original tape. Follow the procedure below to make this type of tape.

#### 1. Record your favorite music source on the jam box or cassette deck.

*Be sure to record on only one side of the tape (side A or B). That is, use Tracks 1 and 2 to record on the jam box or the cassette deck, and keep Tracks 3 and 4 empty. (See the diagram below.)*

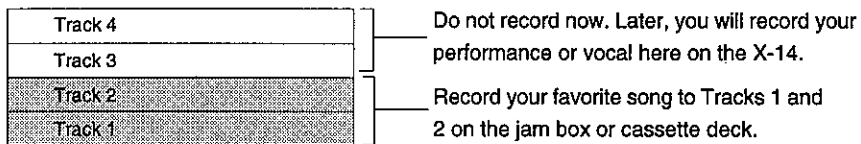

#### 2. Insert the recorded tape in the X-14, and follow the "Overdubbing" procedure described previously to record your performance or vocal to Tracks 3 and 4.



*Note that the law prohibits recording copyrighted or broadcast music, except for recordings intended only for personal use.*



## Troubleshooting

Symptom	Check Point	Corrective Action
The power is not turned on when you press the power switch on.	Is the AC adapter plugged in securely?	Check the connection at the AC outlet and the DC IN jack of the X-14.
Sound flutters or skips.	Is the head dirty?	Clean the head.
	Are you using a type of tape other than high position?	Use a high-position tape.
You cannot record with the internal microphone.	Is the INT MIC switch turned on?	Turned switch on.
	Is the sound source connected to the Microphone Input jack or the Guitar/Keyboard Input jack?	Disconnect the sound source.
You cannot record with an external microphone.	Is another sound source connected to the Guitar/Keyboard Input jack?	Disconnect the sound source.
The sound from the external microphone sound distorted or clipping.	Is the level appropriate for the external microphone?	Use the TRIM knob to set the optimum level.
The REC button is not pushed in.	Is the write-protection tab on the cassette tape broken?	Place a strip of scotch tape over the broken tab.
The sound cannot be heard through the headphones.	Is the LINE OUT knob turned up?	Turn the LINE OUT knob up.
You cannot record to a desired track.	Is the REC SEL button set correctly?	Press the REC SEL button repeatedly until the desired track is selected.

## Maintenance

### 1. Cleaning the exterior

**\* For normal cleaning, use a soft dry cloth.**

For stubborn dirt, moisten a cloth in diluted detergent, wring it out firmly, and wipe the dirt off. Then polish with a dry cloth.

Never use solvents such as alcohol, thinner or benzene, since these will damage the printing and finish of the exterior.

### 2. Cleaning the head, roller and capstan

**\* Record/playback head**

As the X-14 is used, the record/playback head will become coated with oxide residue from the tapes. If this residue is allowed to build up, recordings will contain more noise, and dropouts may occur during playback. To prevent this, regular cleaning is important. Use a commercially available cleaning kit etc. to clean the head. If cleaning the head does not restore the sound quality, it is possible that the head is worn. Contact an authorized service station for repair.

**\* Capstan and pinch roller**

The capstan and pinch roller are important parts that hold the tape and move it along at the correct speed. As with the head, these parts can also become dirty with oxide residue and dust, which will cause increased wow or flutter, or even damage the tape by pulling it out of the cassette.

Since cassette tape is very thin, it is especially dangerous to use a cassette deck with dirty pinch rollers. As with the head, it is important to always keep these parts clean. Clean them using a cotton swab or gauze soaked in cleaning solution or isopropyl alcohol. Never use organic solvents such as lacquer thinner, since this will severely damage the pinch rollers.

### 3. Demagnetizing the head

After long periods of use, the head begins to develop a magnetic field in addition to the oxide residue described above. This can also occur if a magnet or a magnetized object (scissors, etc.) is allowed to come near the head or touch it. If the head or capstans become magnetized, frequency response will be degraded and noise will increase. In extreme cases, noise can be created on previously recorded tapes that you playback, rendering them useless.

Once a month or so, you should use a demagnetizer (head eraser) to demagnetize the head. Carefully read and follow the instructions included with your demagnetizer, and do not allow it to come near recorded tapes.

## Specifications

### INPUTS

#### GUITAR/KEYBOARD input

Connector	φ 6mm PHONE jack × 1
Input impedance	20k Ω or higher
Reference input level	-20dBV

#### MIC input

Connector	φ 6mm PHONE jack × 1
Input impedance	20k Ω or higher
Reference input level	-50dBV ~ -30dBV (adjustable with the TRIM knob)

Internal Microphone Condenser type × 1 (ON/OFF)

### OUTPUTS

#### LINE OUT (L, R)

Connector	RCA pin jack × 2
Output load impedance	10k Ω or higher
Reference output level	-10dBV

#### PHONES

Connector	φ 6mm STEREO PHONE jack × 1
Output load impedance	16 Ω or higher
Maximum output	20mW (at 32 Ω )

Recording tape Less than C-90 (TYPE II /HIGH position)  
Record tracks 4 tracks, one direction

Tape speed	4.76cm/s
Tape rewinding time	140 seconds (when a C-60 tape is used)
Frequency response	
Mixer section	20Hz ~ 20kHz
Recorder section	40Hz ~ 12kHz
<b>Heads</b>	
Rec/Play	4-track, 4-channel recording/playback
Erase	4-track, 4-channel erase
<b>Power Supply</b>	
	FOSTEX AC adaptor, AD-12A
	DC12V (12 ~ 16V), 8W
<b>Weight</b>	
	Approx. 1.1kg (excluding the AC adaptor)
<b>Dimensions (mm)</b>	
	275(W) × 65(H) × 177(D)
<b>Accessories</b>	
	Owner's manual × 1, AC adaptor × 1

\* Specifications and appearance are subject to change without notice for product improvement.

## Block Diagram

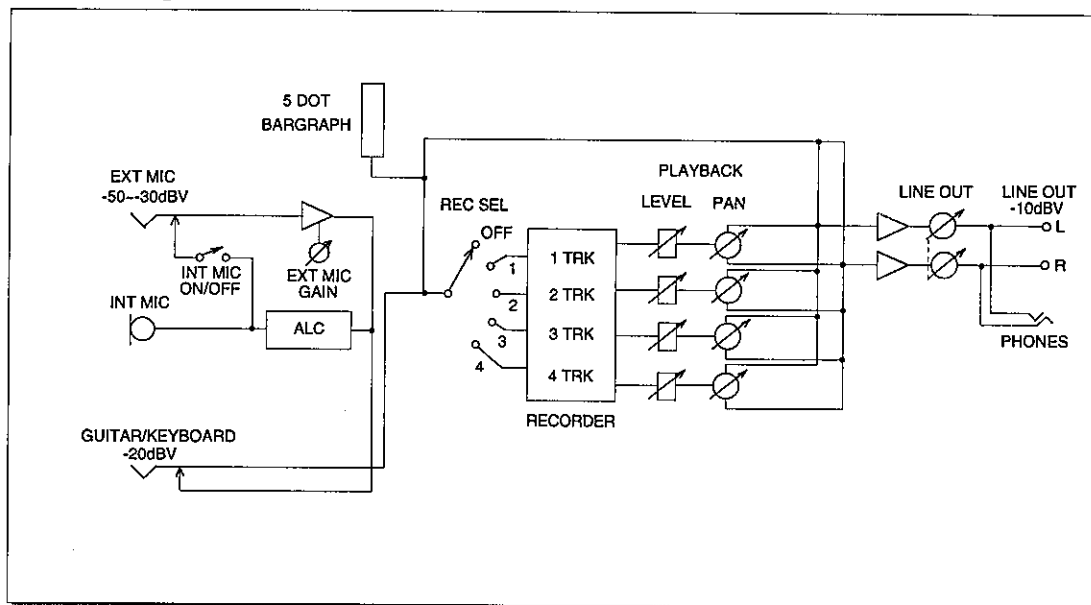

### Declaration of EC Directive

This equipment is compatible with the EMC Directive (89/336/EEC) - Directive on approximation of member nation's ordinance concerning the electromagnetic compatibility and with the Low Voltage Directive (73/23/EEC) - Directive on approximation of member nation's ordinance concerning electric equipment designed to be used within the specified voltage range.

### The Affect of Immunity on This Equipment

The affect of the European specification EN50082-1 (coexistence of electromagnetic waves - common immunity specification) on this equipment are as shown below.

\* In the electrical fast transient / burst requirements, radiated electromagnetic field requirements and static electricity discharging environment, this could be affected by generation of noise and distortion in some cases.

### FOSTEX DISTRIBUTORS LIST IN EUROPE

\* Including non - EU countries. \* underlined: contracted distributors (as of April, 1999)

#### <AUSTRIA>

NAME: ATEC Audio-u. Videogeräte VertriebsgesmbH.  
ADD: Im Winkel 5, A-2325 Velm, Austria  
TEL: (+43) 2234-74004, FAX: (+43) 2234-74074

#### <BELGIUM>

NAME: Sound Industries NV  
ADD: Bijvennestraat 1A, B3500 Hasselt, Belgium  
TEL: (+32) 11-232355, FAX: (+32) 11-232172

#### <DENMARK>

NAME: SC Sound ApS  
ADD: Malervej 2, DK-2630 Taastrup, Denmark  
TEL: (+45) 4399-8877, FAX: (+45) 4399-8077

#### <FINLAND>

NAME: Noretton Oy Audio  
ADD: P. O. Box 22, FIN-02631 Espoo, Finland  
TEL: (+358) 9-5259330, FAX: (+358) 9-52593352

#### <FRANCE>

NAME: Musikengro  
ADD: ZAC de Follieuses, B. P. 609, 01706 Les Echets, France  
TEL: (+33) 472 26 27 00, FAX: (+33) 472 26 27 01

#### <GERMANY>

NAME: Studiosound & Music GmbH  
ADD: Industriestrasse 20, D-35041 Marburg, F. R. Germany  
TEL: (+49) 6421-92510, FAX: (+49) 6421-925119

#### <GREECE>

NAME: Bon Studio S. A.  
ADD: 6 Zaimi Street, Exarchia, 106.83 Athens, Greece  
TEL: (+30) 1-3809605-8, 3302059, FAX: (+30) 1-3845755

#### <ICELAND>

NAME: I. D. elrf. electronic Ltd.  
ADD: Armula 38 108 Reykjavik, Iceland  
TEL: (+354) 588 5010, FAX: (+354) 588 5011

#### <ITALY>

NAME: Recoton Italia Srl.  
ADD: V. I Maggio, N 18, 40050 Quarto Inferiore, (BO) Italy  
TEL: (+39) 051-768576, FAX: (+39) 051-768336

#### <THE NETHERLANDS>

NAME: JEMKE ROOS AUDIO B. V.  
ADD: Kuiperbergweg 20, 1101 AG Amsterdam, The Netherlands  
TEL: (+31) 20-697-2121, FAX: (+31) 20-697-4201

#### <NORWAY>

NAME: Siv. Ing. Benum A/S  
ADD: P. O. Box 145 Vinderen, 0319 Oslo 3, Norway  
TEL: (+47) 22-139900, FAX: (+47) 22-148259

#### <PORTUGAL>

NAME: Caius - Tecnologias Audio e Musica, Lda.  
ADD: Rua de Santa Catarina, 131 4000 Porto, Portugal  
TEL: (+351) 2-2086009/2001394  
FAX: (+351) 2-2054760/2087488

#### <SPAIN>

NAME: Multitracker, S. A.  
ADD: C/Garcilaso No.9, Madrid 28010, Spain  
TEL: (+34) 91-4470700, 91-4470898  
FAX: (+34) 91-5930716

#### <SWEDEN>

NAME: Professional Television AB  
ADD: Kavallerivagen 24, 172 48 Sundbyberg, Sweden  
TEL: (+46) 8-59798000, FAX: (+46) 8-59798001

#### <SWITZERLAND>

NAME: Audio Bauer Pro AG  
ADD: Bernerstrasse-Nord 182, CH-8064 Zurich, Switzerland  
TEL: (+41) 1-4323230, FAX: (+41) 1-4326558

#### <UK>

NAME: SCV London  
ADD: 3A 6-24 Southgate Road, London N1 3JJ, England, UK  
TEL: (+44) 171-923-1892, FAX: (+44) 171-241-3644

外形寸法  
付属品

275 (幅) × 65 (高さ) × 177 (奥行き) mm  
取扱説明書×1, ACアダプター×1

\* 製品の外観および規格などは、改良のため将来予告なく変更することがあります。

## ブロック・ダイアグラム

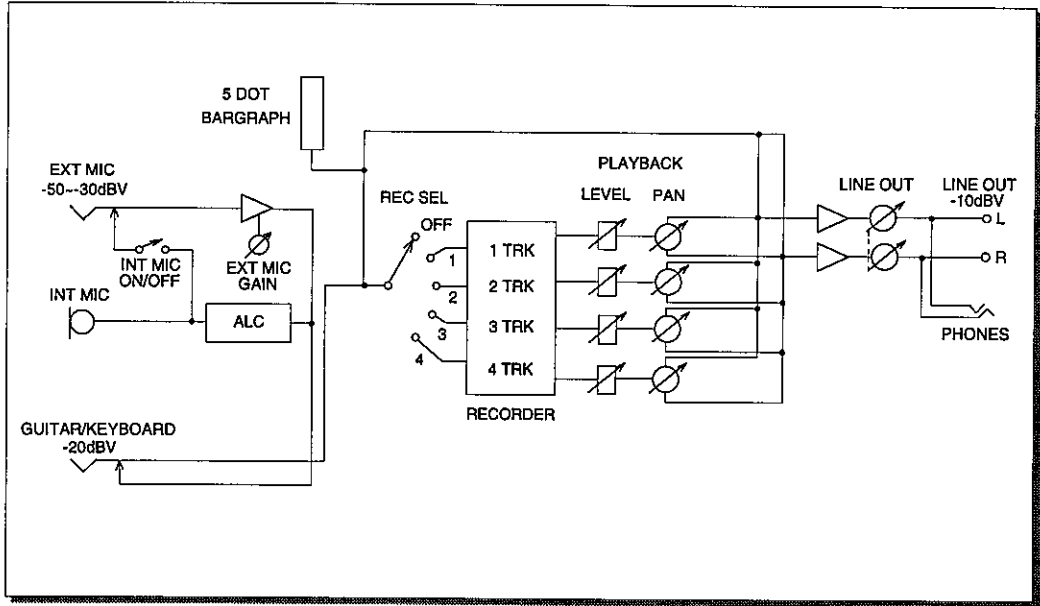

# **Fostex**

**FOSTEX CORPORATION**

3-2-35, Musashino, Akishima-shi, Tokyo 196-0021, Japan

**FOSTEX CORPORATION OF AMERICA**

15431, Blackburn Ave., Norwalk, CA 90650, U. S. A.

フォステクス株式会社

国内営業・企画販促グループ

☎ 196-0021 東京都昭島市武蔵野 3-2-35

☎ 042-546-6355 Fax. 042-546-6067