

NOTE: DO NOT USE STEREO CORD TO TEST THIS GUITAR!!!

|   |                |                                      |  |
|---|----------------|--------------------------------------|--|
| GIBSON GUITAR CORP.<br>641 MASSMAN DRIVE<br>NASHVILLE, TN 37210<br>(615) 391-1580 |                | PART: WIRING DIAGRAM - LPJP (REV. A) |  |
| SCALE: N/S  | DATE: 11/27/96 | MAT'L:                               |  |
| DRAWN: R.A.   | CHK: J.M.      | PART NO: DIA-LP-JE                   |  |

NOTE: DRAWING AND ALL OF THE INFORMATION HEREON ARE THE CONFIDENTIAL PROPERTY OF GIBSON, INC. AND MAY NOT BE REPRODUCED OR USED FOR ANY PURPOSE EXCEPT AS EXPRESSLY AUTHORIZED IN WRITING BY GIBSON, INC.

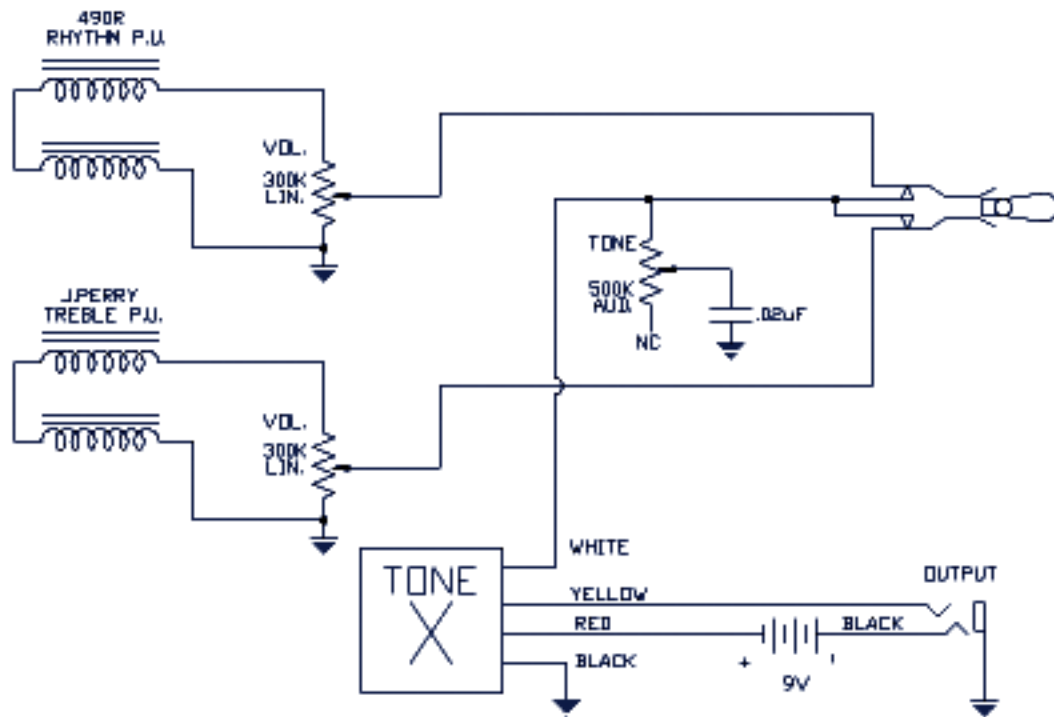

Note: Tailpiece to be connected to common ground.

NOTE: THIS DRAWING AND ALL OF THE INFORMATION HEREON ARE THE CONFIDENTIAL PROPERTY OF GIBSON, INC. AND MAY NOT BE REPRODUCED OR USED FOR ANY PURPOSE EXCEPT AS EXPRESSLY AUTHORIZED IN WRITING BY GIBSON, INC.

|     |          |         |      |   |                                      |
|-----|----------|---------|------|---|--------------------------------------|
| LTR | REVISION | PCA NO. | DATE | GIBSON GUITAR CORP.<br>641 MASSMAN DRIVE<br>NASHVILLE, TN 37210<br>(615) 391-1580 | PART: JOE PERRY WIRING SCHEMATIC     |
|     |          |         |      |   | SCALE: DATE: 11/26/96 MAT'L:         |
|     |          |         |      |   | DRAWN: R.T.A. CHK: PART NO: SCH-LPJP |