

**SE 100  
PREAMPLIFIER  
OWNER'S MANUAL**

**Hafler**™

A Division of Rockford Corporation  
613 South Rockford Drive  
Tempe, Arizona 85281  
602 - 967 - 3565

**INDEX**

Specifications . . . . . Page 1

Installation . . . . . Page 3

Overseas Use . . . . . Page 3

Input/Output Description . . . . . Page 3

User Adjustable Features . . . . . Page 8

Phono Board Installation . . . . . Page 9

Cartridge Loading . . . . . Page 11

Warranty . . . . . Page 13

## SE 100 SPECIFICATIONS

### PHONO SECTION (MEASUREMENTS AT REC OUT)

**FREQUENCY RESPONSE:**  
20 Hz-20 kHz,  $\pm 0.1$  dB

**MAXIMUM OUTPUT VOLTAGE:** 5  
volts RMS, 20 Hz-20 kHz

**TOTAL HARMONIC DISTORTION  
& NOISE:** 20 Hz-20 kHz  
Moving Magnet: .002%  
Moving Coil: .009%

**SENSITIVITY:**  
(For 0.5 Volts RMS @ 1 kHz)  
Moving Magnet: 6.0 mV RMS  
Moving Coil: 600  $\mu$  V RMS

**SIGNAL TO NOISE RATIO:**  
(A-weighted, relative to 0.5 V RMS)  
Moving Magnet: -87 dB  
Moving Coil: -80 dB

**MAXIMUM INPUT SIGNAL:**  
( @ 1 kHz)  
Moving Magnet: 65 mV RMS  
Moving Coil: 6.5 mV RMS

**INPUT IMPEDANCE:**  
Nominal 47,000 ohms  
Moving Magnet: 220 pF as sup-  
plied, user adjustable  
Moving Coil: 100 ohm as supplied,  
user adjustable

**GAIN:** @ 1 kHz  
Moving Magnet: +38.5 dB  
Moving Coil: +58.5 dB

### LINE SECTION

**FREQUENCY RESPONSE:**  
20 Hz-20 kHz,  $\pm 0.1$  dB

**BANDWIDTH:** 10 Hz-150 kHz, -3  
dB, into 10k ohm load

**MAXIMUM OUTPUT VOLTAGE:** 5  
volts RMS, 20 Hz-20 kHz

**TOTAL HARMONIC DISTORTION  
& NOISE:** .005%, 20 Hz-20 kHz @  
2 volts RMS

**SENSITIVITY:** (For 0.5 V RMS  
OUTPUT): 65 mV RMS

**SIGNAL TO NOISE RATIO:** -100  
dB (A-weighted, relative to 2.0 V  
RMS)

**INPUT IMPEDANCE:** 33 k ohms

**OUTPUT IMPEDANCE:**  
Line Out: 316 ohms  
Record Out: 2150 ohms

### GENERAL:

**INPUTS:** Phono/Aux, CD, Tuner,  
Video, Tape

**OUTPUTS:** Record, Out 1, Out 2

**CONTROLS:** Input Selectors,  
Balance, Volume, Tone Defeat,  
Bass, Treble, Out 1, Out 2, Power

**CONVENIENCE OUTLETS:**  
(Polarized) 1 Unswitched, 2  
Switched, 5 amp continuous, 72  
amp surge

**SIZE:** 17" wide x 3" high x 8 1/2" deep

## INTRODUCTION

---

Your SE 100 preamplifier uses superb, all discrete, J-FET amplification stages to achieve a high level of sonic purity suitable for the most demanding listener. The J-FET devices share many characteristics with the best of vacuum triodes and actually outperform them in areas such as high speed and very low noise.

All the components in the SE 100 have been selected for their excellent audio performance as well as their reliability. They have been incorporated in unique Hafler complementary symmetry circuits and carefully arranged on the circuit board in a manner that reduces crosstalk and maintains separation. The placement of the front panel controls follows the flow of the circuitry, and insures the most direct audio path from input to output.

Precise interchannel balance at all frequencies is maintained with close tolerance components, and RIAA phono equalization is engineered to very tight specifications, maintaining accurate phase relationships and correct spatial perspectives. The tone controls, which can provide frequency response contouring, are normally isolated from the circuit for ruler-flat response.

We suggest that you read the installation and operation sections of this manual carefully, even though much may be familiar to you. There are some subtle and significant points which may be new, and their proper appreciation will enable maximum satisfaction with your SE 100. We wish you to have the very best in sound.

## INSTALLATION

---

The gloss black insert on the face-plate of your new Hafler equipment has been packaged with a removable protective coating. Please peel off this protective coating following installation.

When cleaning the face-plate, we advise a soft cotton cloth with a non-abrasive cleaner that is safe for Lexan and painted surfaces. DO NOT use paper towels or any coarse material to clean the face-plate as these materials may scratch the insert.

The SE 100 has the capability of being mounted in a 19" standard rack. This capability relies on replacing the existing endcaps with rackmount endcaps which increase the width of the SE 100 from 17" to 19". They are available upon request from the customer service department 602-967-3565. The part number for one endcap is HWH-176. You will need to order two endcaps. They will be supplied at no charge to the customer. The holes for mounting are spaced for a single, standard rack height. The SE 100, however, is not standard rack height.

## POWER CONNECTIONS

---

The SE 100 in its standard version is wired for 120 volts, 60Hz. It can also be wired for 200 - 240 volt 50/60 Hz operation; however, this requires a transformer change. Please contact the factory for additional details.

## INPUTS--PHONO/AUX

---

The SE 100 is available with, or without, a phono input. Without the phono input, the Phono/Aux input accepts high level signals only. With the phono input, you get a high-gain, low-noise, complementary-symmetry, discrete J-FET circuit with selectable gain for either a moving magnet (MM) or moving coil (MC) input. This gain is selected with a back panel switch. Choose MM for a moving-magnet or high

output moving-coil cartridge (typically 2 - 5 mV) or choose MC for low output moving-coil cartridge (typically 0.2 - 0.5 mV).

» **WARNING: NEVER OPERATE THE MM/MC SWITCH UNLESS THE VOLUME IS TURNED DOWN! THE SUDDEN CHANGE IN GAIN COULD DAMAGE YOUR AMPLIFIER, SPEAKERS, OR EARDRUMS!**

You may also want to change the factory-installed cartridge loads (See the OPTIONAL CARTRIDGE LOADING section). If you happen to have a SE 100 that is not outfitted with the phono eq amp board, it can be ordered from your Hafler dealer and easily installed.

## INPUTS--CD, TUNER, VIDEO

The standard high level inputs are the CD, TUNER, and VIDEO inputs. These inputs may be used with any high level signal source.

## TAPE IN, RECORD OUT, TAPE MONITOR

The TAPE IN is designed to be used in conjunction with the RECORD OUT and a tape deck. The REC. OUT routes the selected input signal (PHONO/AUX., CD, TUNER, VIDEO) to the tape deck for recording. The output signal of the tape deck is returned to the TAPE IN of the SE 100, and can be monitored by selecting the TAPE MON. switch. At first the TAPE MONITOR appears to be only a duplicate of the TAPE OUT signal, but the important difference is that the TAPE MON switch actually breaks the audio path inside the preamplifier, allowing you to listen to the tape deck's output while it's input is being fed by the selected preamplifier signal. This feature is necessary for real-time monitoring of 3-head decks, and is a convenient check that the proper signal is being recorded. If you would like to listen to a pre-recorded tape, simply engage the TAPE MON switch and it will override all other signal inputs. It should be

understood that in the absence of a tape deck, the TAPE IN can be used as an additional high level input, and engaging the TAPE MON. switch is the same as selecting any other input.

## LINE

To add versatility to your audio system, the SE 100 has been provided with two sets of LINE OUT jacks. These two outputs are independently selectable with the OUT1 and OUT2 switches and may be used to drive two different amplifier and speaker systems.

## HEADPHONE

Your SE 100 has been provided with a 1/4 inch aperture, stereo headphone jack. It always has a signal applied to it and will not load the output of the preamplifier when headphones are plugged in. If you would like to listen to headphones only, turn off OUT1 and OUT2. Remember to reduce the volume before turning on OUT1 or OUT2 again, since a normal listening level for your headphones may correspond to a surprisingly high volume in your loudspeakers.

## OUTPUT MUTING

At turn-on, OUT1 and OUT2 will be muted for approximately 7 seconds until the preamp circuits have settled, and it is ready for operation. During mute you will still be able to hear low level audio at the preamplifier outputs, so don't be fooled into turning up the volume too soon.

At turn-off, whether by operating the preamp's power switch, or as a result of external power failure, the line output will be instantaneously muted. When power is restored to the preamp, the muting circuit will again delay signal output to the amplifier for a few seconds.

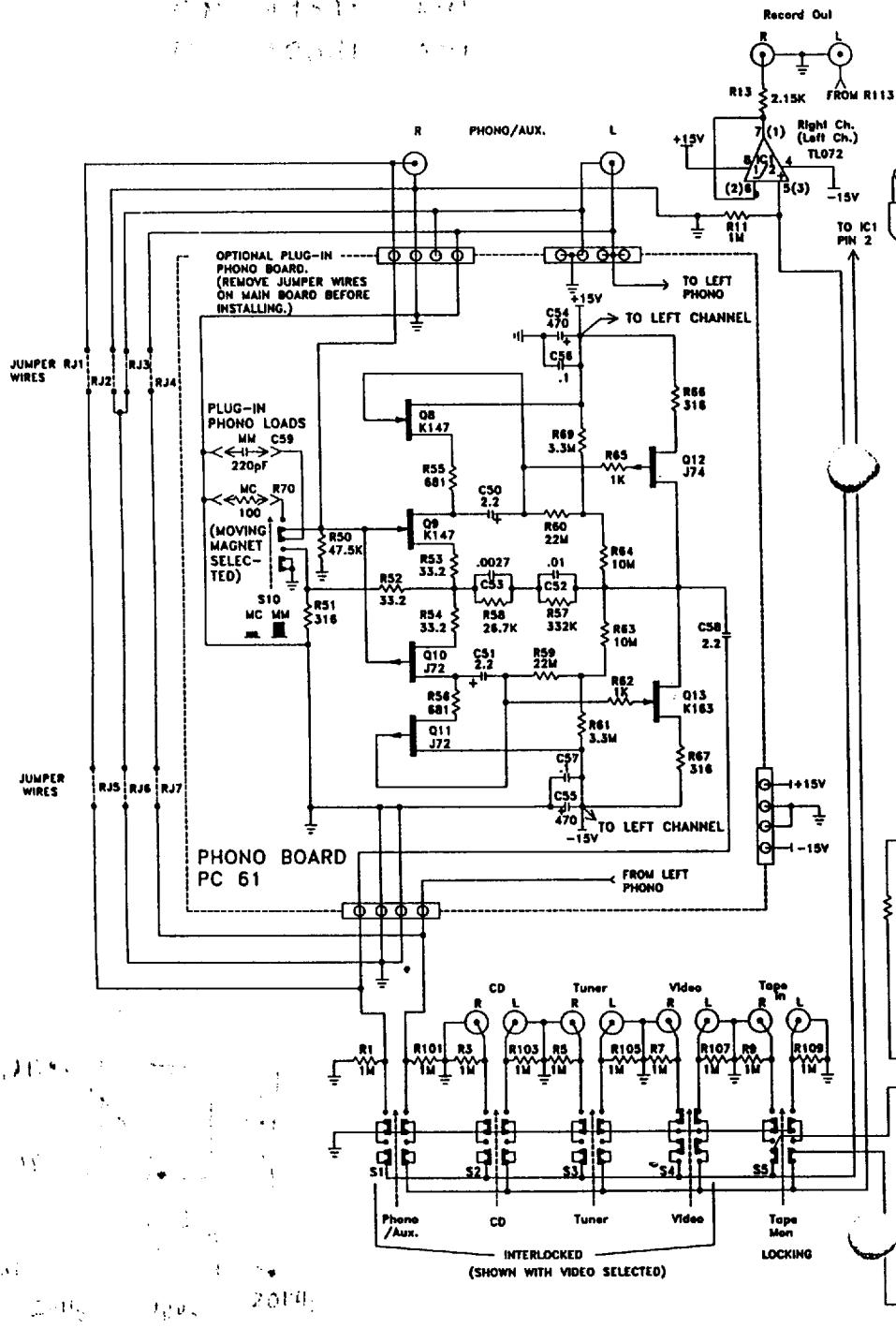

- UNLESS SPECIFIED OTHERWISE: RESISTOR VALUES ARE IN OHMS  
CAPACITOR VALUES ARE IN  $\mu\text{F}$
- RIGHT CHANNEL SHOWN; LEFT CHANNEL REFERENCE DESIGNATORS CORRESPOND TO THE RIGHT CHANNEL WITH THE ADDITION OF 100, I.E. LEFT CHANNEL RESISTOR R120 CORRESPONDS TO RIGHT CHANNEL RESISTOR R20
- TRANSFORMER MAY BE 120 VAC OR 240 VAC, NOTE THE FUSE VALUE FOR EACH CASE
- MAIN BOARD - PC 57
- PHONO BOARD - PC 61
- DESIGNATORS IC2, R2, R4, R6, R8, R10, R12, R14, AND R6B DO NOT EXIST FOR THE PURPOSE OF THIS SCHEMATIC

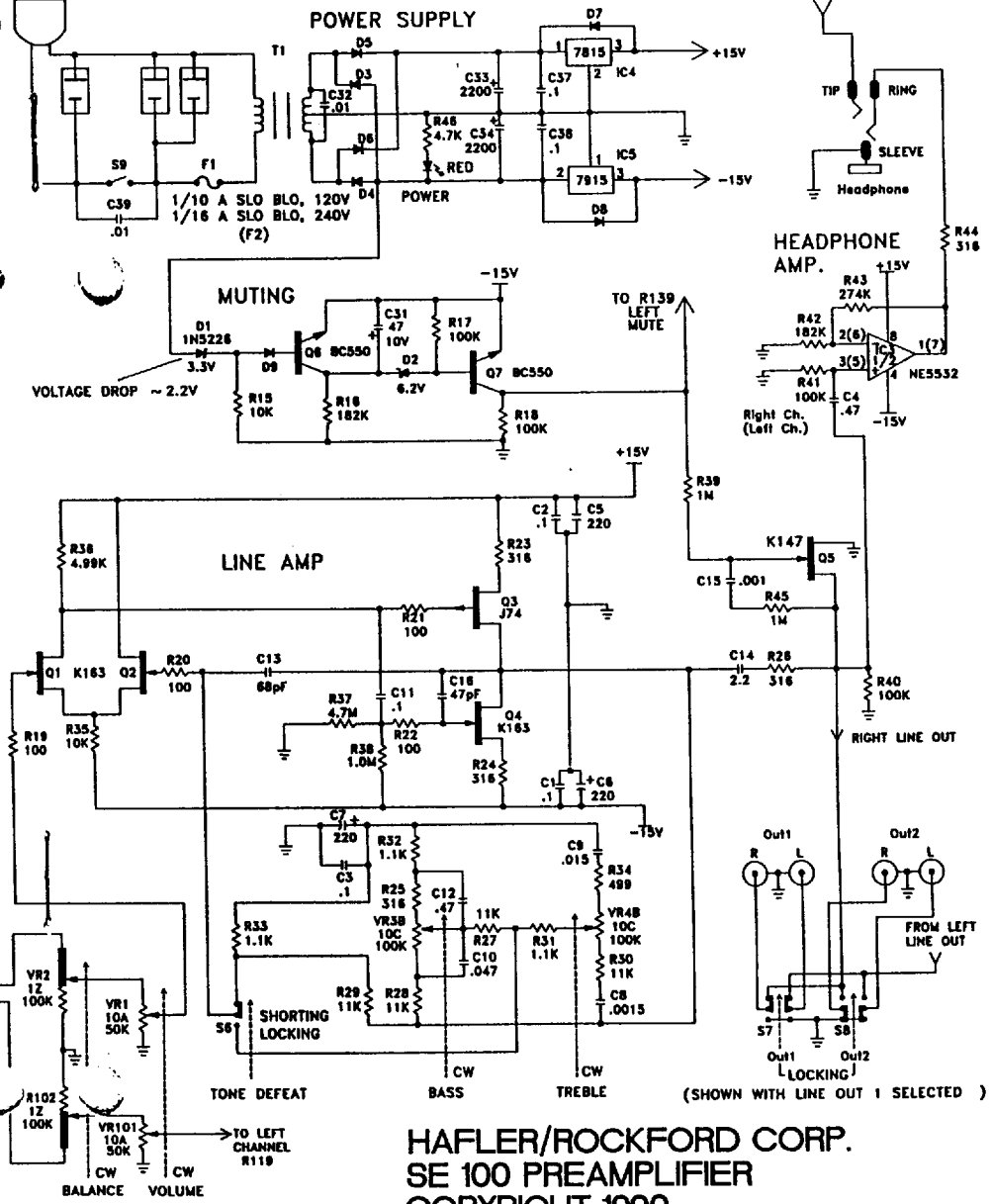

HAFNER/ROCKFORD CORP.  
SE 100 PREAMPLIFIER  
COPYRIGHT 1990

## ADJUSTABLE FEATURES

### BALANCE CONTROL

This adjusts the proportion of left or right channel signals to the Line outputs and headphones. In its detented center position the channels will be matched to  $\pm 0.1$  dB. Only the left signal will be heard with the control fully counterclockwise, and only the right signal at full clockwise rotation. The Balance control is used to optimize the stereo effect by balancing the acoustic output between left and right speakers.

### VOLUME CONTROL

This step action control was selected for its excellent inter-channel gain tracking, and for its low contact distortion. Clockwise from the 12 o'clock position it increases in increments of approximately 1 dB. From 12 o'clock counter-clockwise it progresses in increasing increments to full attenuation.

### TONE CONTROLS, TONE DEFEAT

Engaging the TONE DEFEAT switch on the SE 100 disconnects the tone controls from the circuit for a flat frequency response. Disengaging the TONE DEFEAT switch allows the user to modify the signal with the tone controls to make up for TREBLE or BASS deficiencies in the reproduced sound.

### PHONO BOARD OPTION

If you purchased your SE 100 preamplifier without the phono equalization amplifier, your Phono/Aux input is a high level input, and will not work with a turntable. If you would like a phono input, you can purchase the Phono Equalization Amplifier board from your Hafler dealer, and

have a qualified technician install it according to the following instructions.

## INSTALLING PHONO BOARD (FOR QUALIFIED PERSONNEL ONLY)

**WARNING! UNPLUG UNIT FROM AC POWER SOURCE BEFORE REMOVING COVER! OTHERWISE YOU RISK SEVERE ELECTRICAL SHOCK AND DAMAGE TO THE PHONO BOARD!**

- 1) Remove the 4 screws under the unit which secure the top cover, and slide it off to the rear.
- 2) Remove the 7 jumper wires shown in the illustration. They can be clipped out or desoldered.
- 3) Insert the 3 plastic circuit board supports into the component side of the phono board and snap them down tightly, so that the button top sits flat against the board.
- 4) Guide the phono board onto the main board and proceed carefully, checking that all the connector pins are aligned with their mating part before completely inserting the phono board. It should snap into place with no free play. Check that all 4 pins of each connector have been inserted properly. If some of the pins have missed their connector, you may have to remove the bottom cover to release the circuit board supports. Before you attempt to install the phono board again, take care to straighten out any bent connector pins.
- 5) Add the button to the MM/MC switch, and replace the cover(s).

## OPTIONAL CARTRIDGE LOADING

Optional cartridge loading is a "fine-tuning" matter, and many cartridges work quite well without it. ONLY a cartridge's manufacturer can provide proper recommendations for this process, as every cartridge is different. ONLY you can say for sure whether or not it produces meaningful sonic improvement--for you. For those who wish to change the factory installed loading, we have included a very flexible system which automatically switches loading components when MM or MC is selected.

Your preamplifier has been supplied with 100 ohm resistors for MC and 220 pF capacitors for MM. While these values are suitable for most cartridges, you may wish to alter them as described below.

## INSTALLING CARTRIDGE LOADS ( FOR QUALIFIED PERSONNEL ONLY )

The preamplifier must always be UNPLUGGED from AC before removing its cover. Full AC line voltage is present at numerous locations inside the unit.

Remove the 4 screws under the unit which secure the top cover, and slide it off, to the rear. The diagram below shows how to cut, form and plug-in optional loads. Observe carefully which sockets are for MM (capacitors) and for MC (resistors).

Even if you are experimenting, you must replace the cover before re-plugging in the unit to AC--not only for safety reasons, but to shield hum and interference which can totally invalidate any attempts at sonic evaluation.

### CAUTION:

*When low value resistors are installed and automatically selected by the high-gain MC position (button IN) of the PHONO-GAIN switch, accidentally using this setup for a HIGH OUTPUT cartridge can result in deceptively normal output levels, but with improper cartridge frequency-response.*

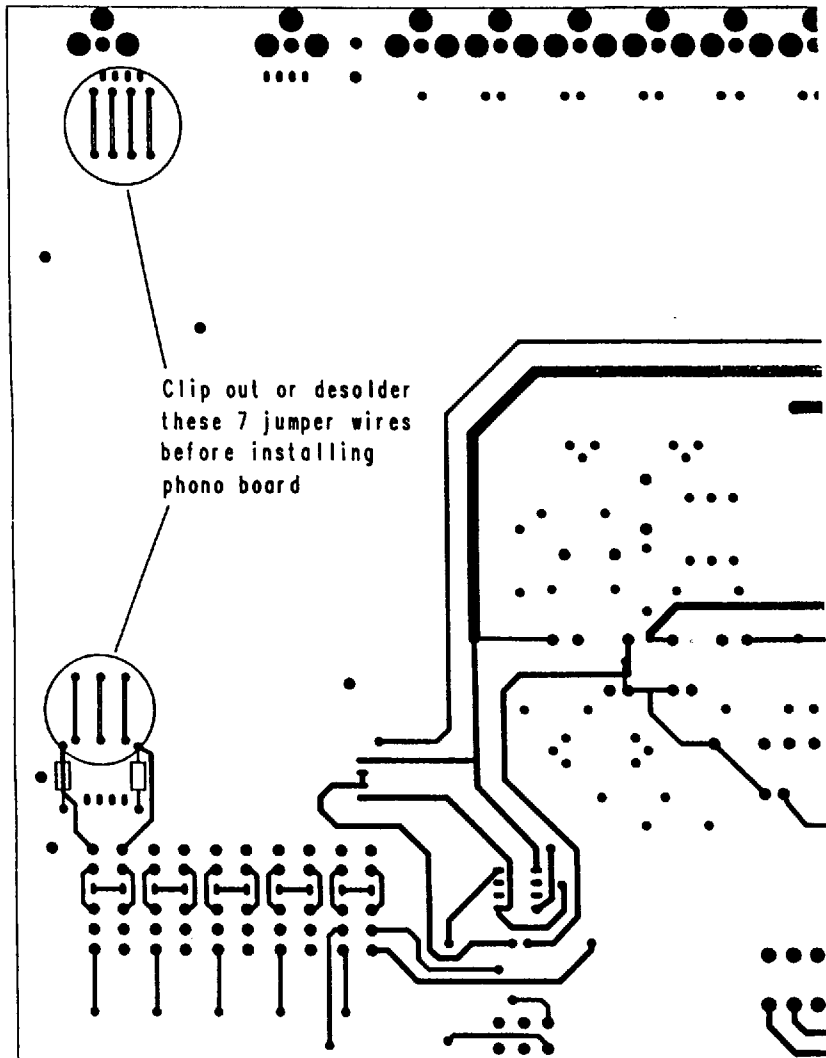



## SERVICE POLICY AND LIMITED WARRANTY

If you encounter any difficulty or have any question concerning your SE 100 preamplifier, please call our Technical Service Department weekdays, 8 am to 3:30 pm Mountain Standard Time, at 602-967-3565.

Should you have any doubts as to whether the preamplifier is malfunctioning and requires service, please call us before sending in for repair. All units being returned (regardless of warranty status) must receive a Return Authorization (RA) number. In addition, we can offer trouble-shooting assistance that may simplify or even eliminate the need for factory service.

The Hafler SE 100 is warranted for 3 years from date of purchase, including parts, labor, and return shipping costs from the factory to the owner within the Continental USA.

It is the owner's responsibility to pay shipping (preferably UPS) to the factory: collect shipments will not be accepted. Units under warranty should be accompanied by a copy of a dated Bill Of Sale. Use the original carton and all packing materials, and be sure to include a return address, and a brief description of the difficulty, including whether it occurs continuously, or intermittently.

This warranty gives you specific legal rights. You may also have other rights which vary from state to state.

