

# JVC

## SERVICE MANUAL

CD / SD RECEIVER

### KD-AR8500, KD-SHX8500

Area suffix

J ----- Northern America

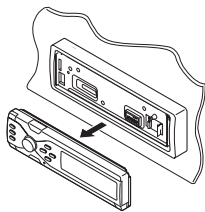

**EXAD**



KD-AR8500

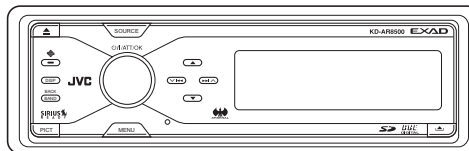

KD-SHX8500

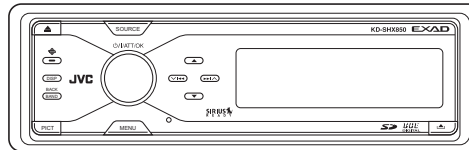

	KD-AR8500 J	KD-SHX8500 J
ARSENAL rogo	○	×

Lead free solder used in the board (material : Sn-Ag-Cu, melting point : 219 Centigrade)

### TABLE OF CONTENTS

1	PRECAUTIONS .....	1-3
2	SPECIFIC SERVICE INSTRUCTIONS .....	1-6
3	DISASSEMBLY .....	1-7
4	ADJUSTMENT .....	1-22
5	TROUBLESHOOTING .....	1-29

# SPECIFICATION

<b>AUDIO AMPLIFIER SECTION</b>		
Power Output	35 W RMS × 4 Channels at 4 Ω and [ $<$ or $=$ ] 1% THD+N	
Signal-to-Noise Ratio	85 dBA (reference: 1 W into 4 Ω)	
Load Impedance	4 Ω (4 Ω to 8 Ω allowance)	
Equalizer Control Range	Frequencies : Graphic EQ	63 Hz, 125 Hz, 250 Hz, 500 Hz, 1 kHz, 2 kHz, 4 kHz, 8 kHz, 12.5 kHz (9 bands)
	Frequencies : Parametric EQ	3 bands (Band 1/2/3) 20 Hz, 25 Hz, 31.5 Hz, 40 Hz, 50 Hz, 63 Hz, 80 Hz, 100 Hz, 125 Hz, 160 Hz, 200 Hz, 250 Hz, 315 Hz, 400 Hz, 500 Hz, 630 Hz, 800 Hz, 1 kHz, 1.2 kHz, 1.6 kHz, 2 kHz, 2.5 kHz, 3.2 kHz, 4 kHz, 5 kHz, 6.3 kHz, 8 kHz, 10 kHz, 12.5 kHz, 16 kHz, 20 kHz (31 frequencies)
	Level	±10 dB
Frequency Response	40 Hz to 20 000 Hz	
Line-In Level/Impedance	LINE IN	1.5 V/20 kΩ load
Line-Out Level/Impedance	LINE OUT	5.0 V/20 kΩ load (full scale)
Output Impedance	1 kΩ	
Power Supply Unit	DC/DC converter	
Other Terminals	SUBWOOFER OUT, Changer control, Steering wheel remote input	
<b>TUNER SECTION</b>		
Frequency Range	FM	87.5 MHz to 107.9 MHz (with channel interval set to 200 kHz) 87.5 MHz to 108.0 MHz (with channel interval set to 50 kHz)
	AM	530 kHz to 1 710 kHz (with channel interval set to 10 kHz) 531 kHz to 1 602 kHz (with channel interval set to 9 kHz)
FM Tuner	Usable Sensitivity	11.3 dBf (1.0 μV/75 Ω)
	50 dB Quieting Sensitivity	16.3 dBf (1.8 μV/75 Ω)
	Alternate Channel Selectivity (400 kHz)	65 dB
	Frequency Response	40 Hz to 15 000 Hz
	Stereo Separation	35 dB
	Capture Ratio	1.5 dB
AM Tuner	Sensitivity	20 μV
	Selectivity	65 dB
<b>CD/SD PLAYER SECTION</b>		
Type	Compact disc player	
Signal Detection System	Non-contact optical pickup (semiconductor laser)	
Number of Channels	2 channels (stereo)	
Frequency Response	5 Hz to 20 000 Hz	
Dynamic Range	98 dB	
Signal-to-Noise Ratio	102 dB	
Wow and Flutter	Less than measurable limit	
MP3 (MPEG Audio Layer 3)	Max. Bit Rate	320 kbps
WMA (Windows Media Audio)	Max. Bit Rate	192 kbps
Playable SD Card	Format	FAT 12/16
	Storage	Up to 512 MB
Playable Audio Format for SD Card	MP3/WMA	
<b>GENERAL</b>		
Power Requirement	Operating Voltage	DC 14.4 V (11 V to 16 V allowance)
Grounding System	Negative ground	
Allowable Operating Temperature	0°C to +40°C (32°F to 104°F)	
Dimensions (W × H × D)	Installation Size (approx.)	182 mm × 52 mm × 159 mm (7-3/16" × 2-1/16" × 6-5/16")
	Panel Size (approx.)	188 mm × 58 mm × 13 mm (7-7/16" × 2-5/16" × 9/16")
Mass (approx.)	1.7 kg (3.8 lbs) (excluding accessories)	

- Design and specifications are subject to change without notice.
- Microsoft and Windows Media are either registered trademarks or trademarks of Microsoft Corporation in the United States and/or other countries.
- SD logo is a trademark.

# SECTION 1 PRECAUTIONS

## 1.1 Safety Precautions

 **CAUTION** Burrs formed during molding may be left over on some parts of the chassis. Therefore, pay attention to such burrs in the case of performing repair of this system.

 **CAUTION** Please use enough caution not to see the beam directly or touch it in case of an adjustment or operation check.

## 1.2 Preventing static electricity

Electrostatic discharge (ESD), which occurs when static electricity stored in the body, fabric, etc. is discharged, can destroy the laser diode in the traverse unit (optical pickup). Take care to prevent this when performing repairs.

### 1.2.1 Grounding to prevent damage by static electricity

Static electricity in the work area can destroy the optical pickup (laser diode) in devices such as CD players. Be careful to use proper grounding in the area where repairs are being performed.

(1) Ground the workbench

Ground the workbench by laying conductive material (such as a conductive sheet) or an iron plate over it before placing the traverse unit (optical pickup) on it.

(2) Ground yourself

Use an anti-static wrist strap to release any static electricity built up in your body.

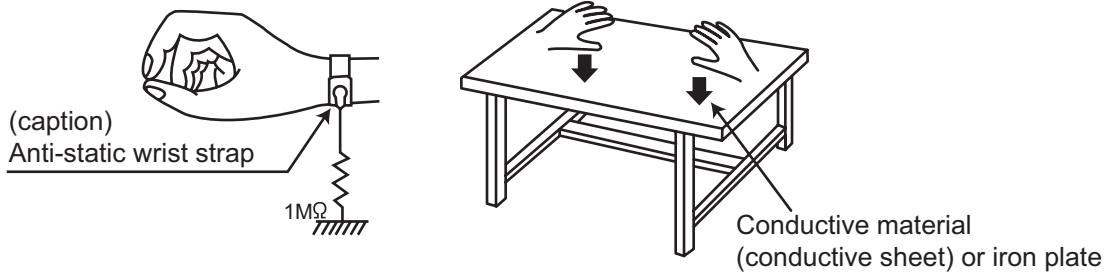

(3) Handling the optical pickup

- In order to maintain quality during transport and before installation, both sides of the laser diode on the replacement optical pickup are shorted. After replacement, return the shorted parts to their original condition. (Refer to the text.)
- Do not use a tester to check the condition of the laser diode in the optical pickup. The tester's internal power source can easily destroy the laser diode.

## 1.3 Handling the traverse unit (optical pickup)

- (1) Do not subject the traverse unit (optical pickup) to strong shocks, as it is a sensitive, complex unit.
- (2) Cut off the shorted part of the flexible cable using nippers, etc. after replacing the optical pickup. For specific details, refer to the replacement procedure in the text. Remove the anti-static pin when replacing the traverse unit. Be careful not to take too long a time when attaching it to the connector.
- (3) Handle the flexible cable carefully as it may break when subjected to strong force.
- (4) It is not possible to adjust the semi-fixed resistor that adjusts the laser power. Do not turn it.

## 1.4 Attention when traverse unit is decomposed

**\*Please refer to "Disassembly method" in the text for the CD pickup unit.**

- Apply solder to the short land before the flexible wire is disconnected from the connector on the CD pickup unit. (If the flexible wire is disconnected without applying solder, the CD pickup may be destroyed by static electricity.)
- In the assembly, be sure to remove solder from the short land after connecting the flexible wire.

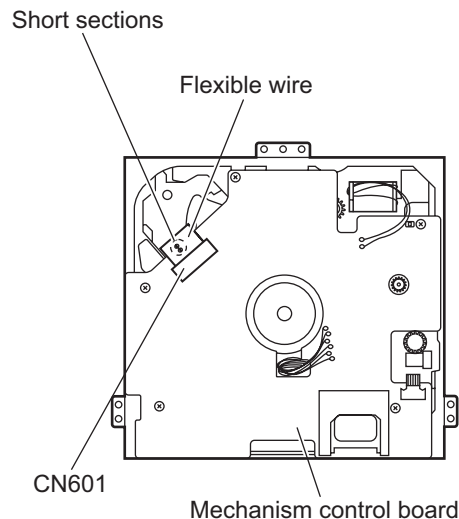

## 1.5 Important for laser products

### 1.CLASS 1 LASER PRODUCT

**2.DANGER** : Invisible laser radiation when open and interlock failed or defeated. Avoid direct exposure to beam.

**3.CAUTION** : There are no serviceable parts inside the Laser Unit. Do not disassemble the Laser Unit. Replace the complete Laser Unit if it malfunctions.

**4.CAUTION** : The CD,MD and DVD player uses invisible laser radiation and is equipped with safety switches which prevent emission of radiation when the drawer is open and the safety interlocks have failed or are defeated. It is dangerous to defeat the safety switches.

**5.CAUTION** : If safety switches malfunction, the laser is able to function.

**6.CAUTION** : Use of controls, adjustments or performance of procedures other than those specified here in may result in hazardous radiation exposure.



**CAUTION** Please use enough caution not to see the beam directly or touch it in case of an adjustment or operation check.

**CAUTION** : Visible and invisible laser radiation when open and interlock failed or defeated.

AVOID DIRECT EXPOSURE TO BEAM.

**ADVARSEL** : Synlig og usynlig laserstråling når maskinen er åben eller interlocken fejler. Undgå direkte eksponering til stråling.

**VARNING** : Synlig och osynlig laserstråling när den öppnas och spärren är urkopplad. Betrakta ej strålen.

**VARO** : Avattaessa ja suojalukitus ohitettuna tai viallisena olet alltiina näkyvälle ja näkymättömälle lasersäteilylle. Vältä säteen kohdistumista suoraan itseesi.

## REPRODUCTION AND POSITION OF LABELS

### WARNING LABEL

CLASS 1  
LASER PRODUCT

**CAUTION** : Visible and invisible laser radiation when open and interlock failed or defeated. AVOID DIRECT EXPOSURE TO BEAM. (e)

**ADVARSEL** : Synlig og usynlig laserstråling når maskinen er åben eller interlocken fejler. Undgå direkte eksponering til stråling. (d)

**VARNING** : Synlig och osynlig laserstråling när den öppnas och spärren är urkopplad. Betrakta ej strålen. (s)

**VARO** : Avattaessa ja suojalukitus ohitettuna tai viallisena olet alltiina näkyvälle ja näkymättömälle lasersäteilylle. Vältä säteen kohdistumista suoraan itseesi. (f)

## **SECTION 2 SPECIFIC SERVICE INSTRUCTIONS**

This service manual does not describe DISASSEMBLY.

## SECTION 3 DISASSEMBLY

### 3.1 Main body section

#### 3.1.1 Removing the front panel assembly (See Fig.1)

- (1) Push the detach button in the lower right part of the front panel assembly.
- (2) Remove the front panel assembly.

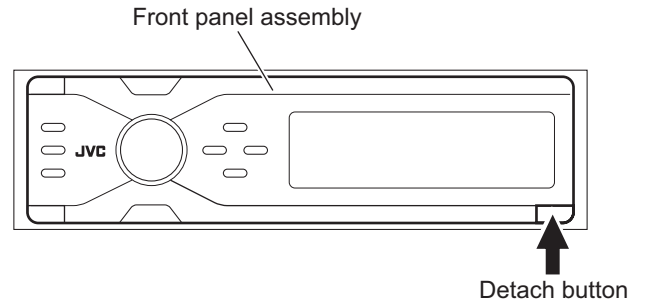

Fig.1

#### 3.1.2 Removing the heat sink (See Fig.2)

##### Reference:

- Remove the front panel assembly as required.
- (1) From the left side of the main body, remove the two screws **A** and three screws **B** attaching the heat sink.
  - (2) Remove the heat sink from the main body.

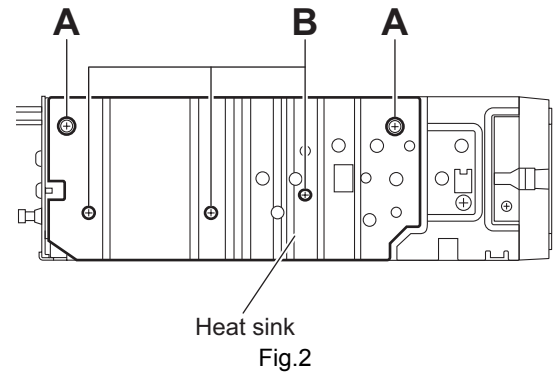

Fig.2

### 3.1.3 Removing the top chassis assembly (See Figs.3 to 6)

- Prior to performing the following procedures, remove the heat sink.

#### Reference:

Remove the front panel assembly as required.

- (1) From the bottom side of the main body, remove the two screws **C** attaching the top chassis assembly to the bottom chassis assembly. (See Fig.3)
- (2) From the both and rear sides of the main body, remove the five screws **D** attaching the top chassis assembly to the bottom chassis assembly. (See Figs.4 to 6)
- (3) Lift the top chassis assembly in the direction of the arrow, disconnect the connector **CN503** on the mechanism control board from the connector **CN721** on the main board. (See Figs.4 to 6)
- (4) Take out the top chassis assembly from the bottom chassis assembly.

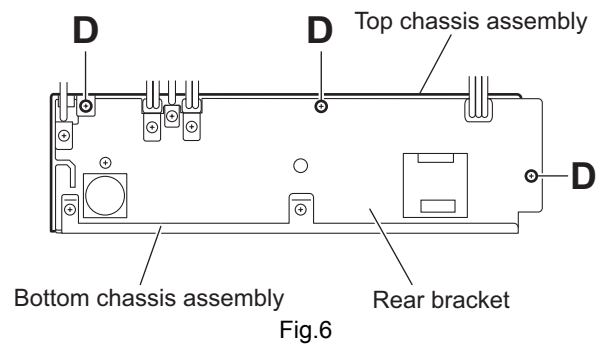
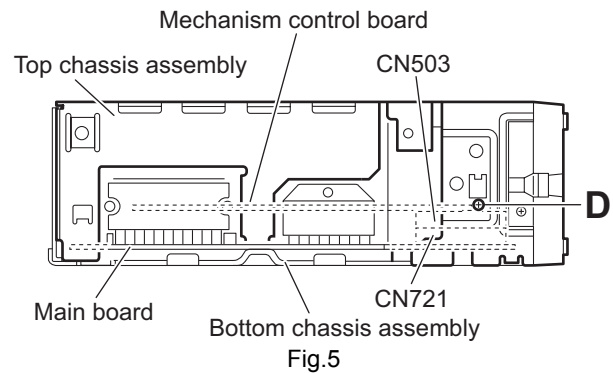
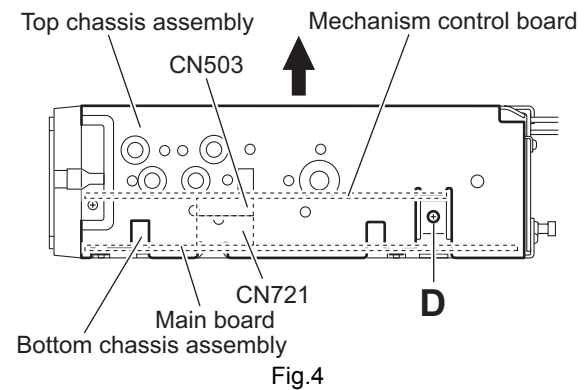
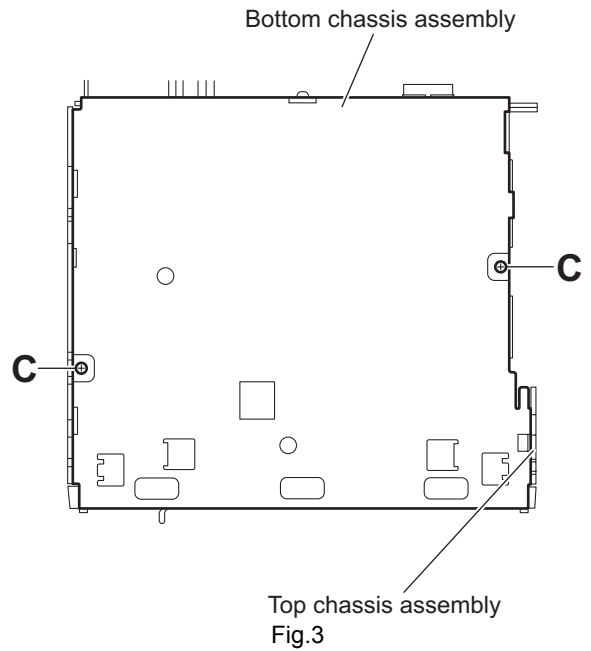



### 3.1.4 Removing the front chassis assembly (See Figs.7 and 8)

- Prior to performing the following procedure, remove the front panel assembly, heat sink and top chassis assembly.
  - (1) From the both sides of the top chassis assembly, remove the two screws **E** attaching the front chassis assembly.
  - (2) Remove the front chassis assembly from the top chassis assembly.

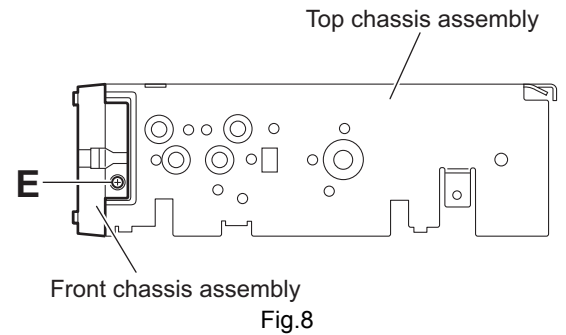
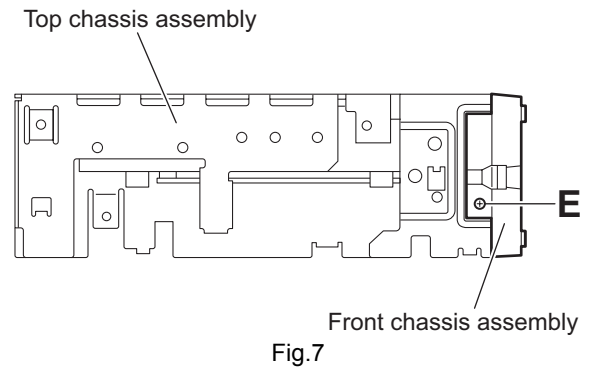

### 3.1.5 Removing the CD mechanism assembly (See Fig.9)

- Prior to performing the following procedures, remove the front panel assembly, heat sink and top chassis assembly.

#### Reference:

Remove the front chassis assembly as required.

- (1) From the inside of the top chassis assembly, remove the three screws **F** attaching the CD mechanism assembly.
- (2) Release the mecha heat sink from the slots **a** on the mechanism control board and remove the mecha heat sink from the main body.
- (3) Take out the CD mechanism assembly from the top chassis.

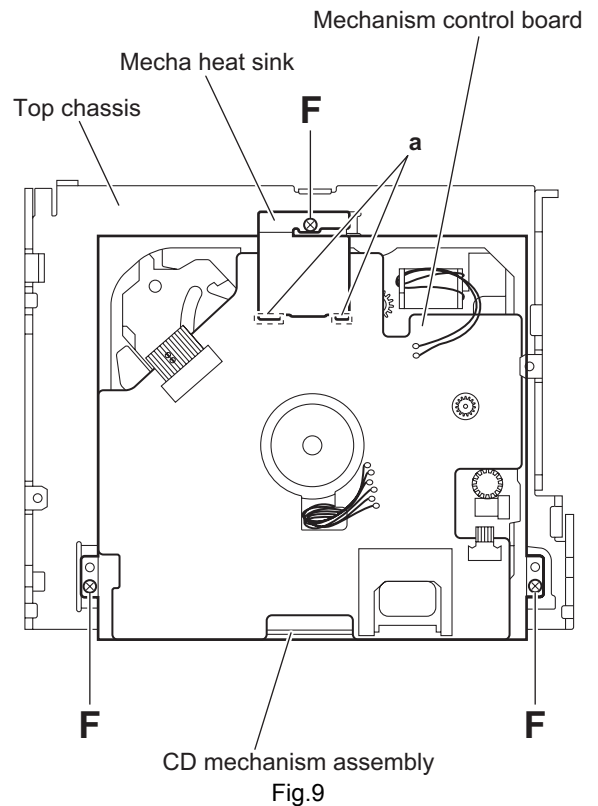

### 3.1.6 Removing the main board (See Figs.10 and 11)

- Prior to performing the following procedures, remove the front panel assembly, heat sink and top chassis assembly.
  - (1) From the rear side of the bottom chassis assembly, remove the two screws **G** attaching the rear bracket to the bottom chassis assembly. (See Fig.10)
  - (2) From the top side of the bottom chassis assembly, remove the two screws **H** attaching the main board to the bottom chassis assembly. (See Fig.11)
  - (3) Release the stopper of the connector **CN701** on the main board in an upward direction, disconnect the card wire from the connector **CN701**. (See Fig.11)
  - (4) Disconnect the wire from the connector of the front door mechanism assembly. (See Fig.11)
  - (5) Disconnect the wire from the connector **CN911** on the main board. (See Fig.11)

**Reference:**

After connecting the wires, fix the wires with the wire holders.

- (6) Take out the main board from the bottom chassis assembly.

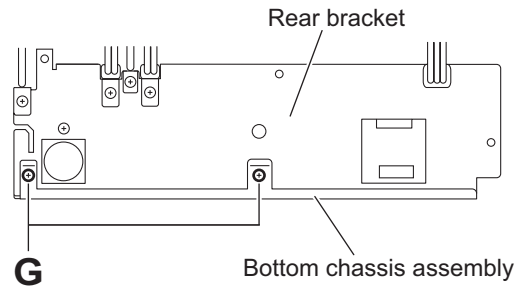

Fig.10

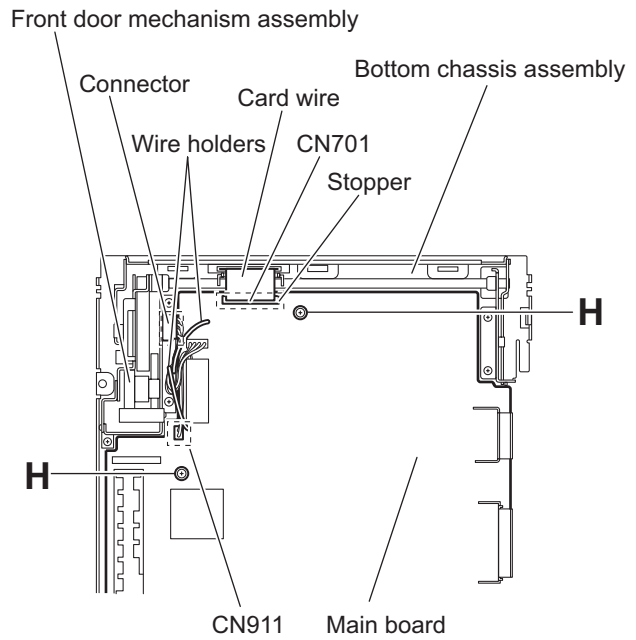

Fig.11

### 3.1.7 Removing the rear bracket (See Fig.12)

- Prior to performing the following procedures, remove the front panel assembly, heat sink, top chassis assembly and main board.
  - (1) Remove the two screws **J** and three screws **K** attaching the wires to the rear bracket.
  - (2) Remove two screws **M** attaching the wire bracket to the rear bracket.
  - (3) From the rear side of the main board, remove the wires from the rear bracket in the direction of the arrow.

**Reference:**

After attaching the rear bracket to the main board, pass the wires through the wire bracket and insert them into the slots of the rear bracket.

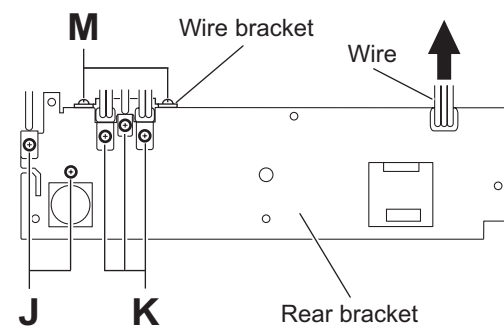

Fig.12

### 3.1.8 Removing the front door mechanism assembly (See Fig.13)

- Prior to performing the following procedures, remove the front panel assembly, heat sink, top chassis assembly and main board.

- (1) From the top side of the bottom chassis assembly, remove the screw **N** attaching the FPC guide to the bottom chassis.
- (2) Remove the five screws **P** attaching the front door mechanism assembly to the bottom chassis.

**Reference:**

When attaching the screws **N** and **P**, apply a locking agent them.

- (3) Take out the front door mechanism assembly from the bottom chassis.

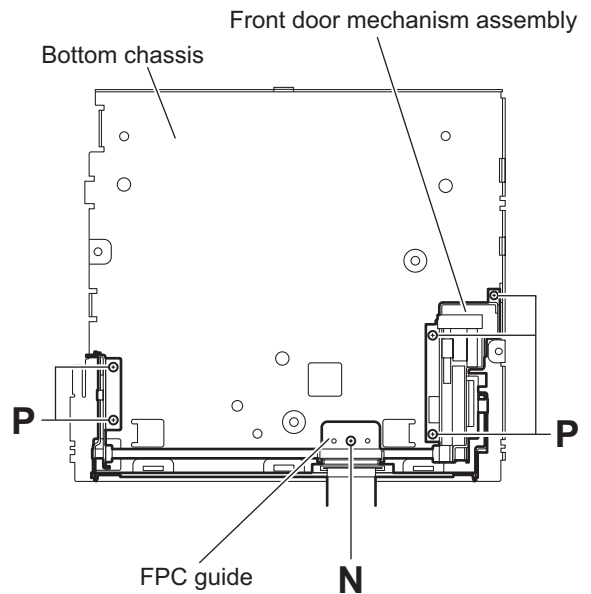

Fig.13

### 3.1.9 Removing the switch board (See Figs.14 to 16)

- Prior to performing the following procedures, remove the front panel assembly.

- (1) From the rear side of the front panel assembly, remove the six screws **Q** attaching the rear cover to the front panel assembly. (See Fig.14)
- (2) Release the two joints **b** of the front panel assembly and remove the rear cover. (See Fig.15.)
- (3) Take out the switch board from the front panel assembly. (See Fig.16)

**Note:**

When removing the rear cover assembly and switch board, be careful not to lose the spring.

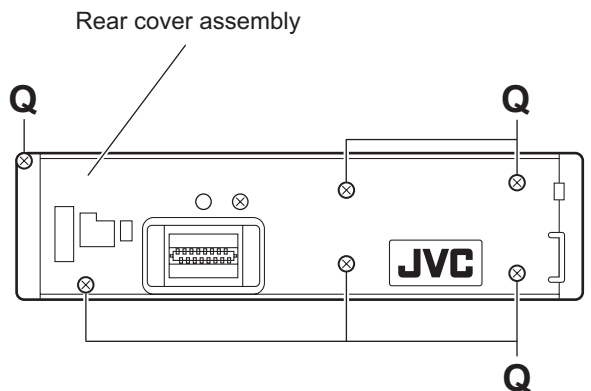

Fig.14

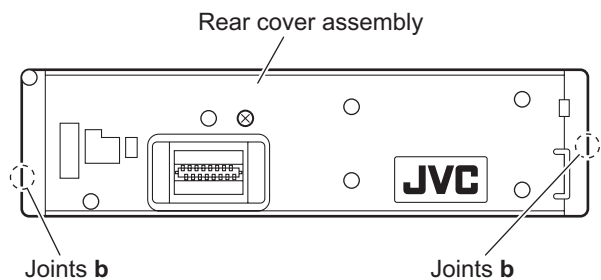

Fig.15

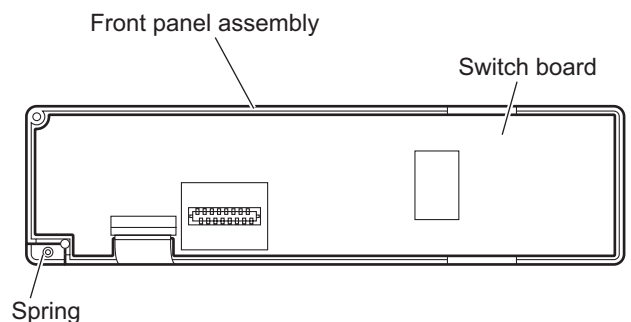

Fig.16

### 3.2 CD mechanism assembly section

- Remove the CD mechanism assembly from the main body.  
(See "3.1.5 Removing the CD mechanism assembly".)

#### 3.2.1 Removing the mechanism control board (See Fig.1)

- (1) From the bottom side of the CD mechanism assembly, solder the short sections on the flexible wire.

**Caution:**

Solder the short sections on the flexible wire before disconnecting the flexible wire from the connector [CN601](#) on the mechanism control board. If you do not follow this instruction, the CD pickup may be damaged.

- (2) Disconnect the flexible wire from the connector [CN601](#) on the mechanism control board.
- (3) Disconnect the flexible wire from the connector [CN602](#) on the mechanism control board.
- (4) Remove the solders from the soldered sections **a** on the mechanism control board and remove the wires of the feed motor.
- (5) Remove the solders from the soldered sections **b** on the mechanism control board, and remove each wire of the spindle motor and other parts.
- (6) Remove the five screws **A** attaching the mechanism control board.

**Caution:**

When reassembling, remove the solders from the short sections after connecting the flexible wire to the connector [CN601](#) on the mechanism control board.

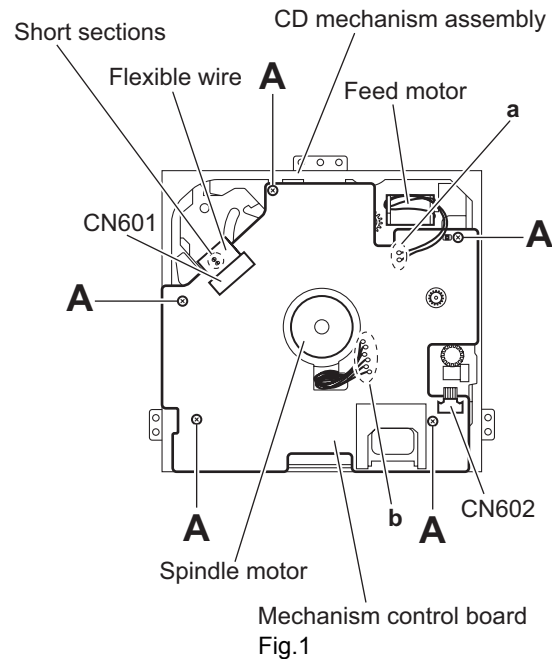

### 3.2.2 Removing the top cover

(See Fig.2)

- (1) From the back side of the CD mechanism assembly, remove the two screws **B** attaching the top cover.
- (2) Take out the top cover in an upward direction.

#### Reference:

When attaching the top cover, set the sections **c** of the top cover under the bending sections **d** of the chassis base 2.

### 3.2.3 Removing the mechanism section

(See Figs.2 to 4)

- Remove the mechanism control board and top cover.
  - (1) From the front side of the CD mechanism assembly, remove the two screws **C** attaching the right and left stoppers. (See Fig.2.)
  - (2) Remove the two floating springs on the bottom side of the CD mechanism assembly. (See Fig.3.)
  - (3) Take out the mechanism section in an upward direction and remove the three damper springs from the dampers. (See Fig.4.)

#### Caution:

- When reassembling the mechanism section, reattach the damper springs to the dampers respectively and insert the three shafts on the bottom of the mechanism section to the dampers. (See Fig.4.)
- Before inserting the shaft to the dampers, apply IPA to the hole of damper.

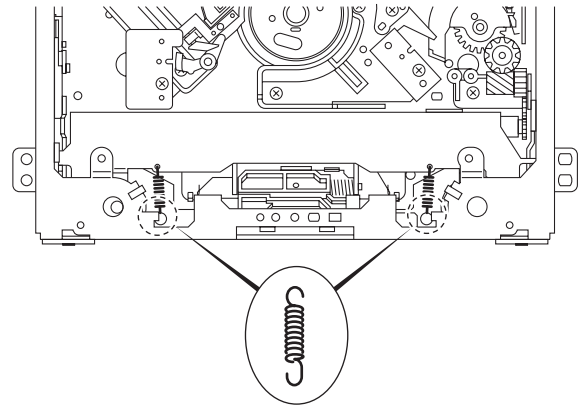
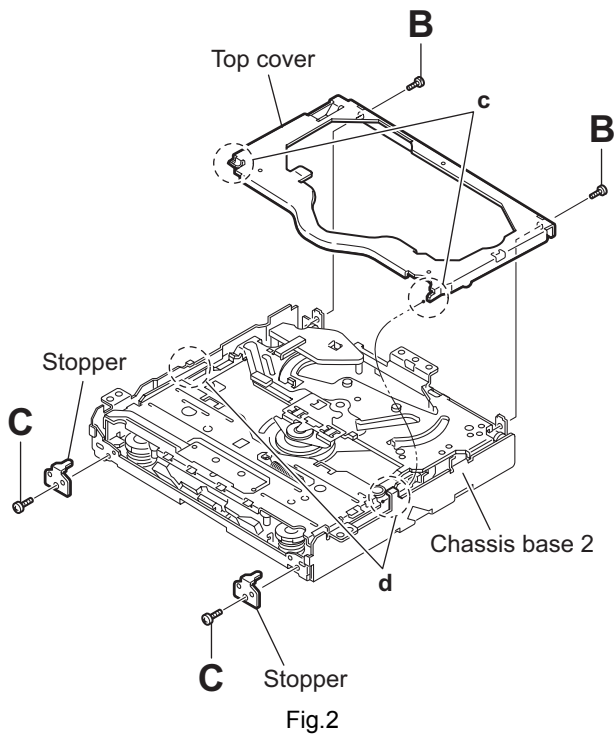
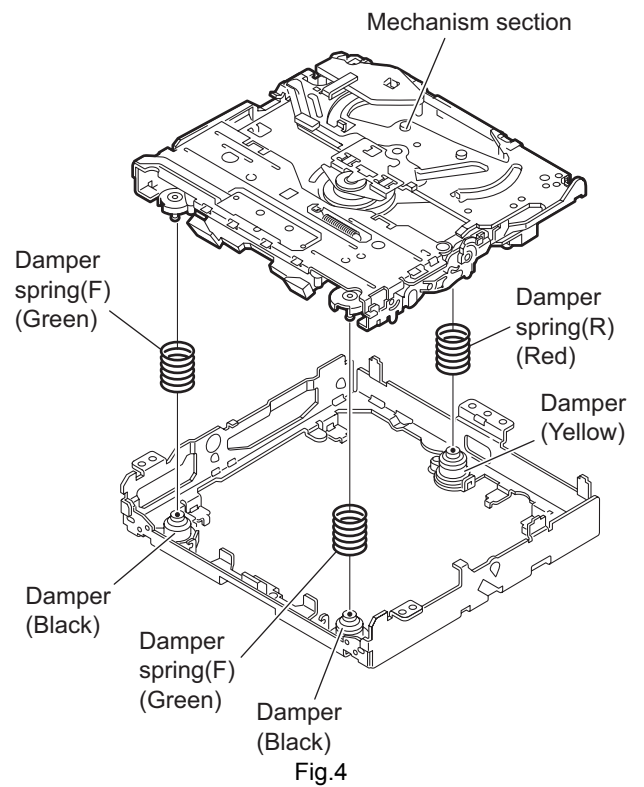

Fig.3



### 3.2.4 Removing the clamber unit (See Figs.5 and 6)

- Remove the mechanism control board, top cover and mechanism section.
  - From the bottom side of the mechanism section, remove the clamber 2 spring. (See Fig.5.)
  - Release section **e** of the clamber spring from the bending section of the CD chassis assembly. (See Fig.6.)
  - Move the clamber unit 2 in the direction of the arrow and release the joints (**f, g**). (See Fig.5.)
  - Take out the clamber unit 2 in an upward direction. (See Fig.5.)

### 3.2.5 Reattaching the clamber unit (See Figs.5 to 9)

- From the bottom side of the mechanism section, attach the clamber spring to the clamber unit 2. (See Figs.5 and 9.)
- Move the clamber unit 2 to set the joints (**f, g**) to each projection of the CD chassis assembly. (See Fig.5.)
- Make sure that section **h** of the clamber unit 2 is inserted to the notch of the CD chassis assembly. (See Figs.5 and 8.)
- Move the clamber spring to the outside of the bending part of the CD chassis assembly. (See Fig.6.)

#### Caution:

When reattaching the clamber unit 2, temporarily hook the end of the clamber spring as shown in the figure to make the work easy. (See Fig.9.)

- Attach the clamber 2 spring to the CD chassis assembly and clamber unit 2. (See Figs.5 and 7.)

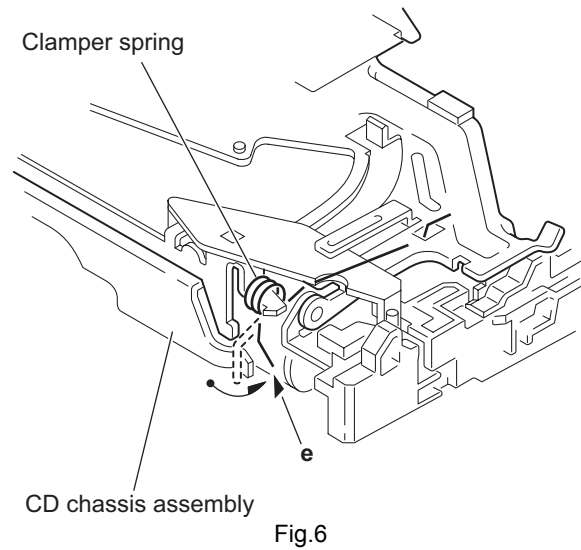
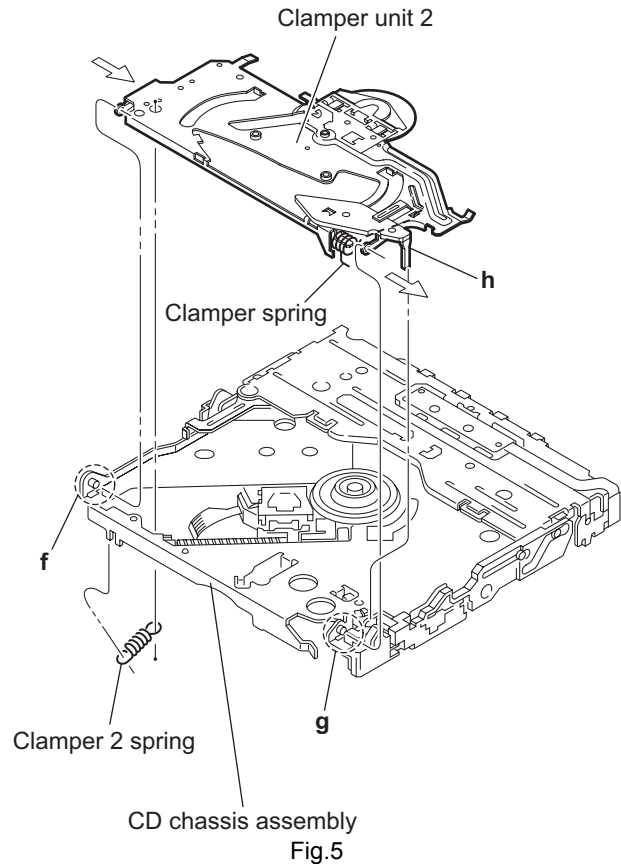

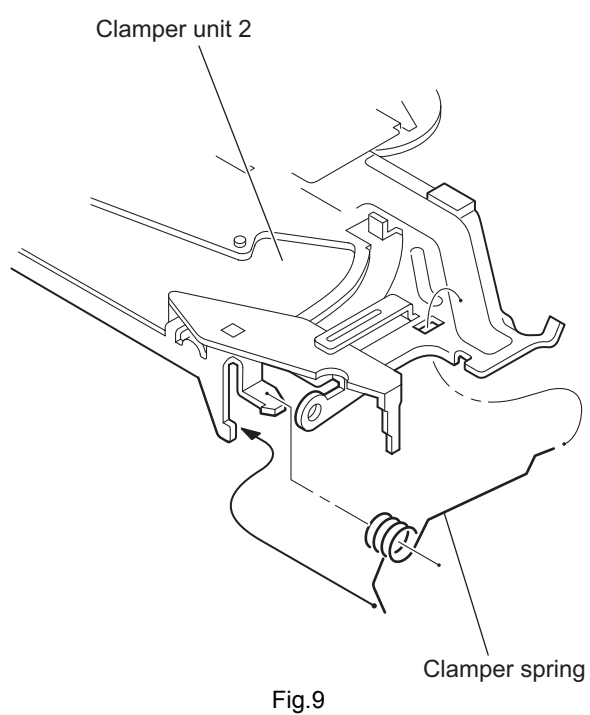
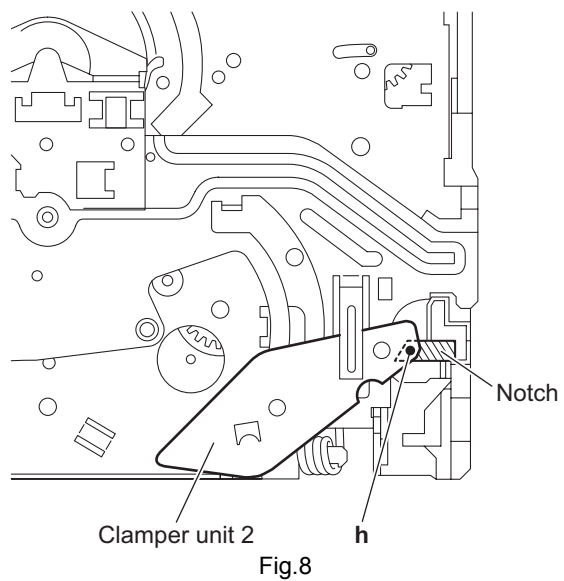
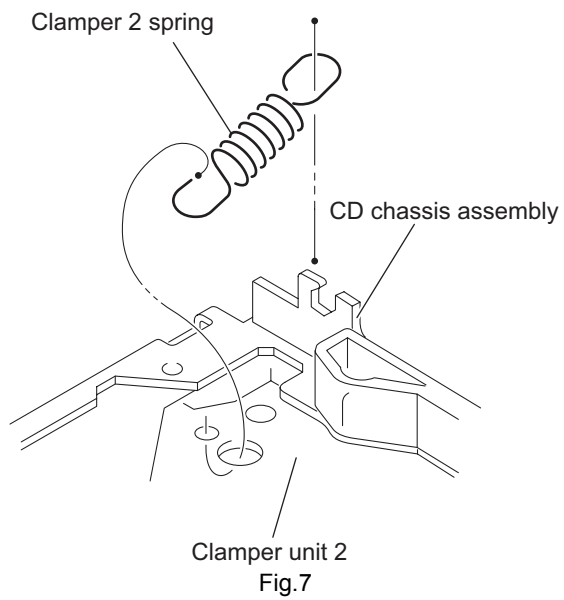

### 3.2.6 Removing the front unit (See Figs10 to 12)

- Remove the mechanism control board, top cover and mechanism section.
  - (1) From the bottom side of the mechanism section, remove the double-stick tape fixing the flexible wire. (See Fig.10.)
  - (2) From the top side of the mechanism section, remove the screw **D** attaching the front unit 2. (See Figs.11 and 12.)
  - (3) Move the front unit 2 toward the front to release the joint **i**. (See Figs.11 and 12.)
  - (4) Release two joints **j** and **k** on the right side of the CD chassis assembly. (See Fig.12.)
  - (5) Take out the front unit 2 in an upward direction.
  - (6) Remove the double-stick tape fixing the flexible wire and remove the two screws **E** attaching the switch wire. (See Fig.12.)

#### Reference:

You can remove the switch wire only without removing the front unit 2.

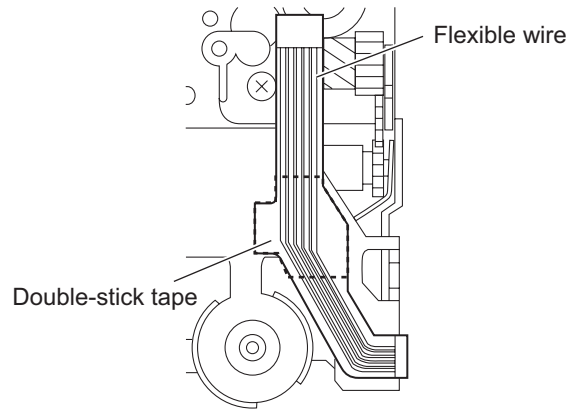

Fig.10

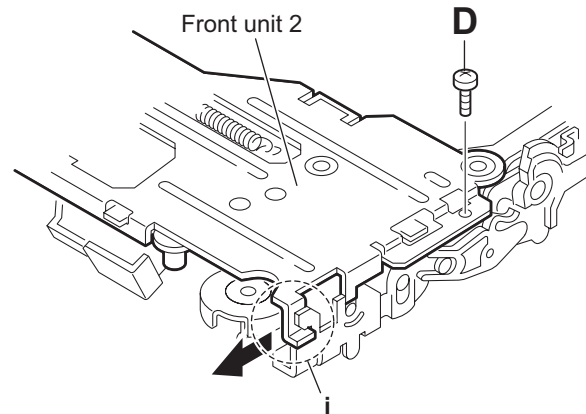

Fig.11

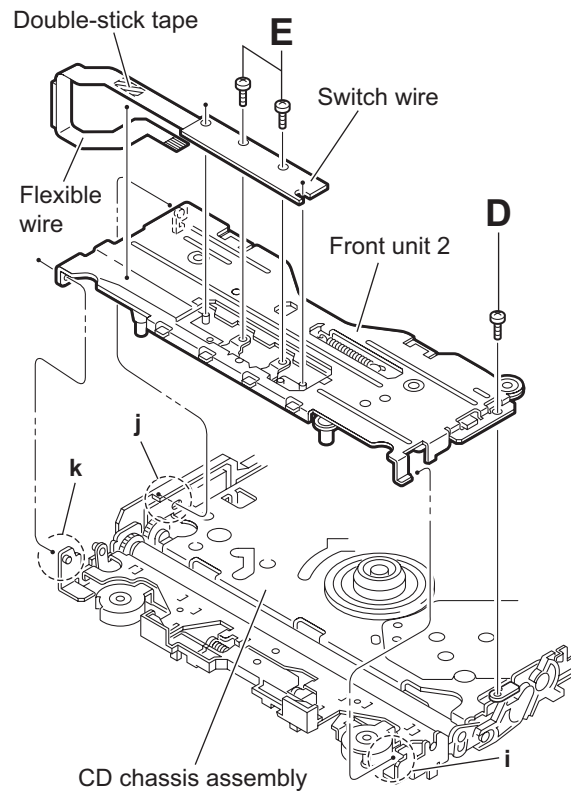

Fig.12



### 3.2.7 Removing the loading arm assembly (See Figs.13 and 14)

- Remove the mechanism control board, top cover, mechanism section and front unit 2.
  - From top side of the mechanism section, move the loading arm assembly in the direction of the arrow. (See Fig.13.)
  - Release the projections from the right and left joints (**m**, **n**) of the CD chassis assembly. (See Figs.13 and 14.)
  - Release the projection from notch **p** of the connect arm on the right side of the mechanism section and release the projection from notch **q** of the slide cam assembly on the left side. (See Figs.13 and 14.)

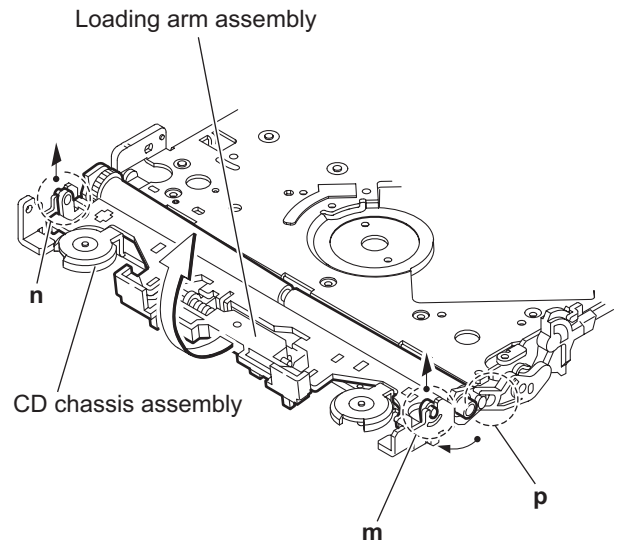

Fig.13

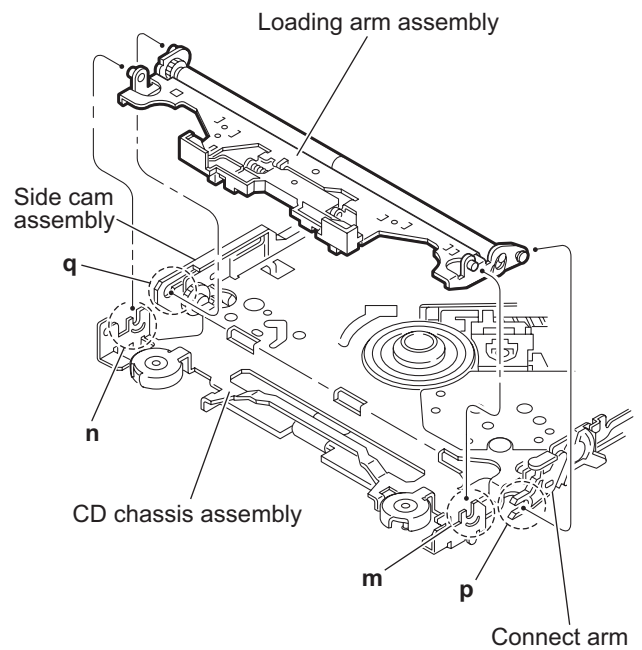

Fig.14

### 3.2.8 Removing the rod (L), rod (R) and roller assembly (See Figs.15 and 16)

- Remove the mechanism control board, top cover, mechanism section, front unit and loading arm assembly.
  - From the bottom side of the loading arm assembly, release the rod (L) and (R) from the joints r. (See Fig.15.)
  - Remove the roller assembly from the loading arm assembly. (See Fig.16.)
  - Remove the two collars and washer from the roller assembly. (See Fig.16.)

**Caution:**

After attaching the roller assembly to the loading arm assembly, attach the rod (L) and (R). Then attach the rods to the right and left collars of the roller assembly. (See Fig.15.)

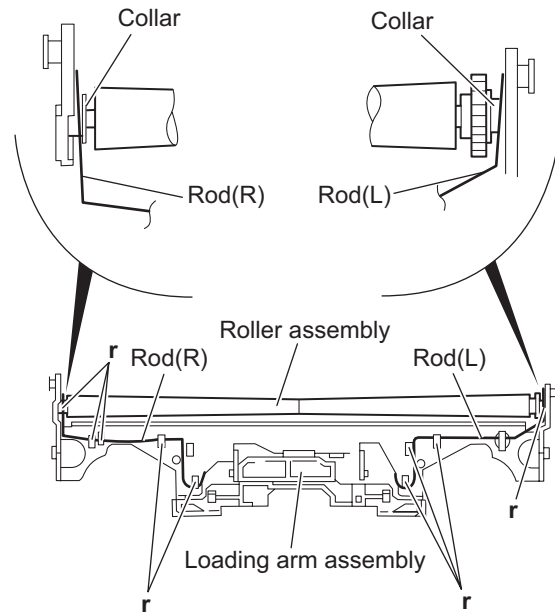

Fig.15

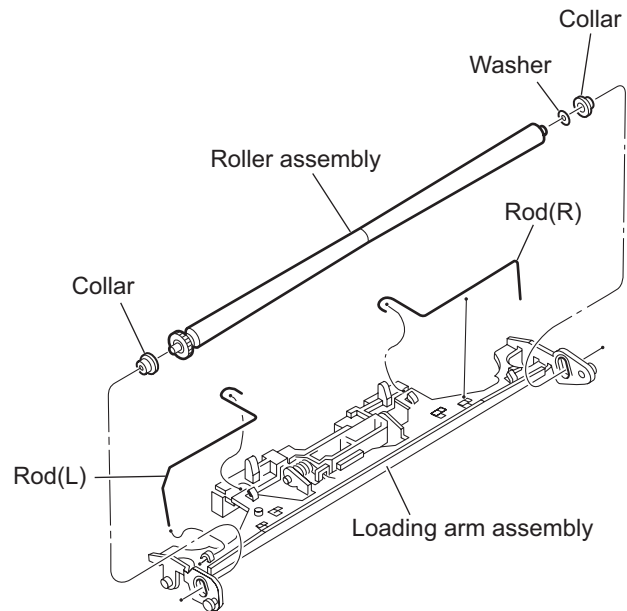

Fig.16

### 3.2.9 Removing the CD pickup (See Figs.17 to 19)

- Remove the mechanism control board.
  - (1) From the bottom side of the CD mechanism assembly, turn the feed gear in the direction of the arrow to move the CD pickup assembly outwards. (See Fig.17.)
  - (2) Remove the screw **F** and remove the thrust spring. (See Fig.17.)
  - (3) Remove the CD pickup assembly in an upward direction from the side of L.S. gear and release the CD pickup assembly from joint **s** of the sub guide. (See Fig.18.)
  - (4) Move the lead screw of the CD pickup assembly in the direction of the arrow to release at joint **t**. (See Fig.18.)
  - (5) Remove the screw **G** attaching the CD rack spring and CD rack plate on the CD pickup assembly. (See Fig.19.)
  - (6) Pull out the lead screw. (See Fig.19.)

#### Caution:

- When attaching the CD pickup assembly, attach the CD pickup assembly at joint **s** of sub guide first, and attach the lead screw to the joint **t** on the L.S. holder 2. (See Fig.18.)
- Perform electric adjustment after replacing the pickup.

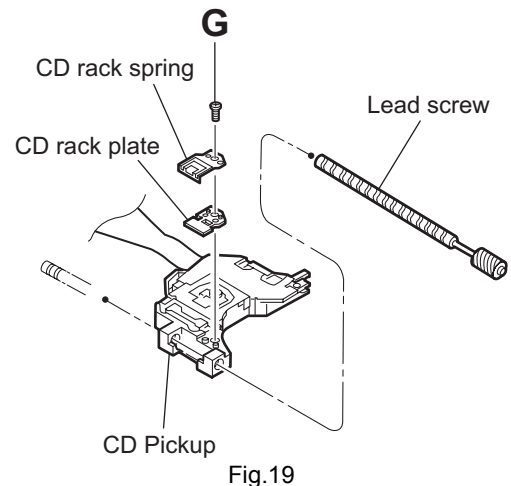
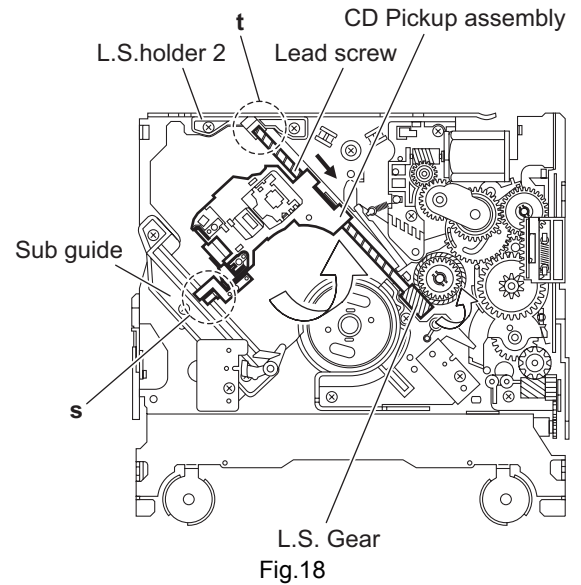
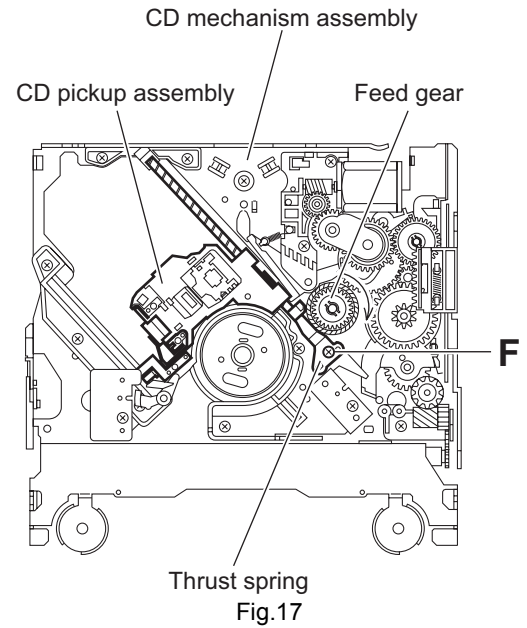

### 3.2.10 Removing the spindle motor (See Fig.20)

- Remove the mechanism control board, top cover, mechanism section and clamber unit.
  - From the top side of the mechanism section, remove the T.table assembly and washer from the spindle motor.
  - Remove the two screws **H** attaching the spindle motor.
  - Take out the spindle motor from the bottom side of the mechanism section.

#### Caution:

Perform adjustment when reattaching the spindle motor.

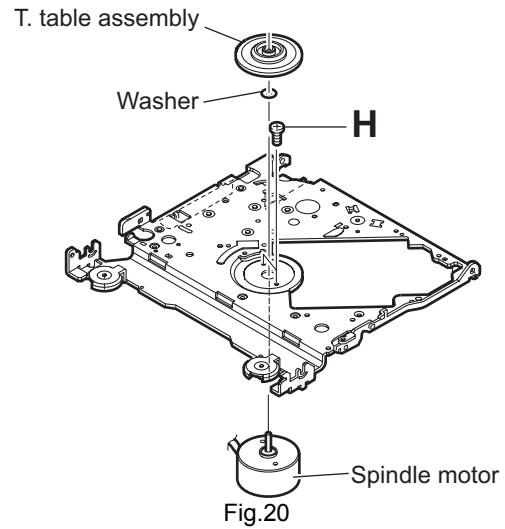

### 3.2.11 Removing the feed motor (See Figs.21 and 22)

- Remove the mechanism control board.
  - From the bottom side of the CD mechanism assembly, remove the feed TRI. spring. (See Fig.21.)
  - Remove the two screws **J** attaching the feed motor assembly. (See Fig.21.)
  - Remove the slit washer from the motor H. assembly and pull out the worm wheel. (See Fig.22.)
  - Remove the two screws **K** attaching the feed motor. (See Fig.22.)

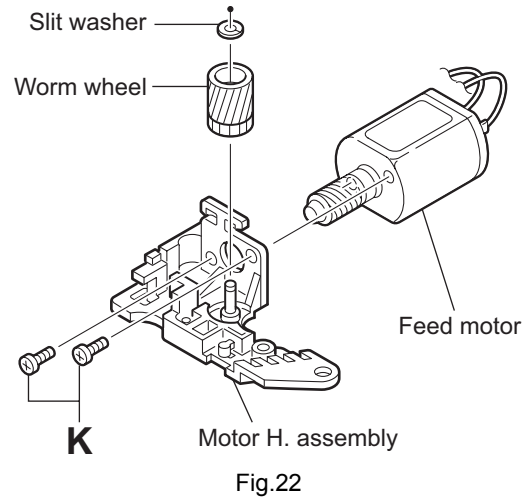
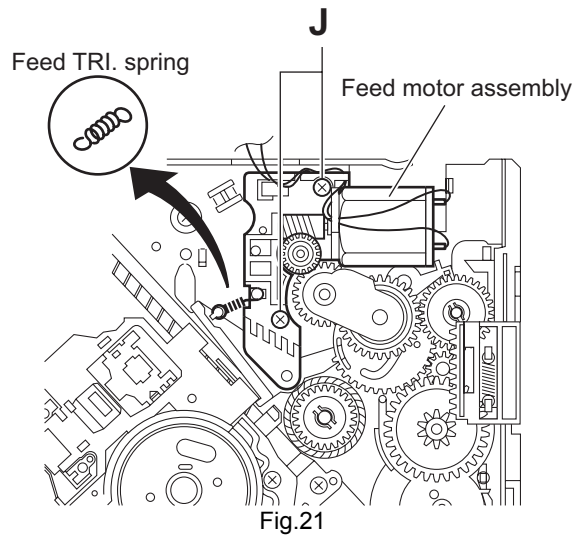

### 3.2.12 Removing the SW board and rest SW board (See Fig.23)

- Remove the mechanism control board.
  - From the bottom side of the CD mechanism assembly, remove the screw **L** attaching the SW board.
  - Remove the screw **M** attaching the rest SW board.

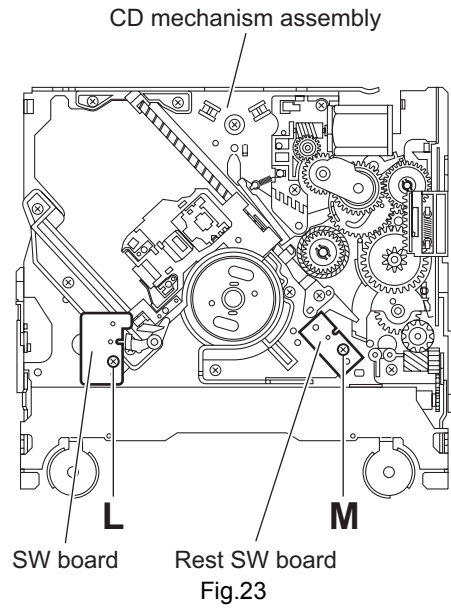

## SECTION 4 ADJUSTMENT

### 4.1 Adjustment method

#### ■ Test instruments required for adjustment

- (1) Digital oscilloscope (100MHz)
- (2) Electric voltmeter
- (3) Digital tester
- (4) Tracking offset meter
- (5) Test Disc JVC :CTS-1000
- (6) Extension cable for check  
EXTDV001-20P × 1

#### ■ Standard volume position

Balance and Bass & Treble volume : Indication "0"  
Loudness : OFF

#### ■ How to connect the extension cable for adjusting

##### Caution:

Be sure to attach the heat sink and rear bracket onto the power amplifier IC and regulator IC respectively, before supply the power. If voltage is applied without attaching these parts, the power amplifier IC and regulator IC will be destroyed by heat.

#### ■ Standard measuring conditions

Power supply voltage	DC14.4V(11 to 16V)
Load impedance	20K $\Omega$ (2 Speakers connection)
Output Level	Line out 5.0V (Vol. MAX)

#### ■ Dummy load

Exclusive dummy load should be used for AM, and FM. For FM dummy load, there is a loss of 6dB between SSG output and antenna input. The loss of 6dB need not be considered since direct reading of figures are applied in this working standard.

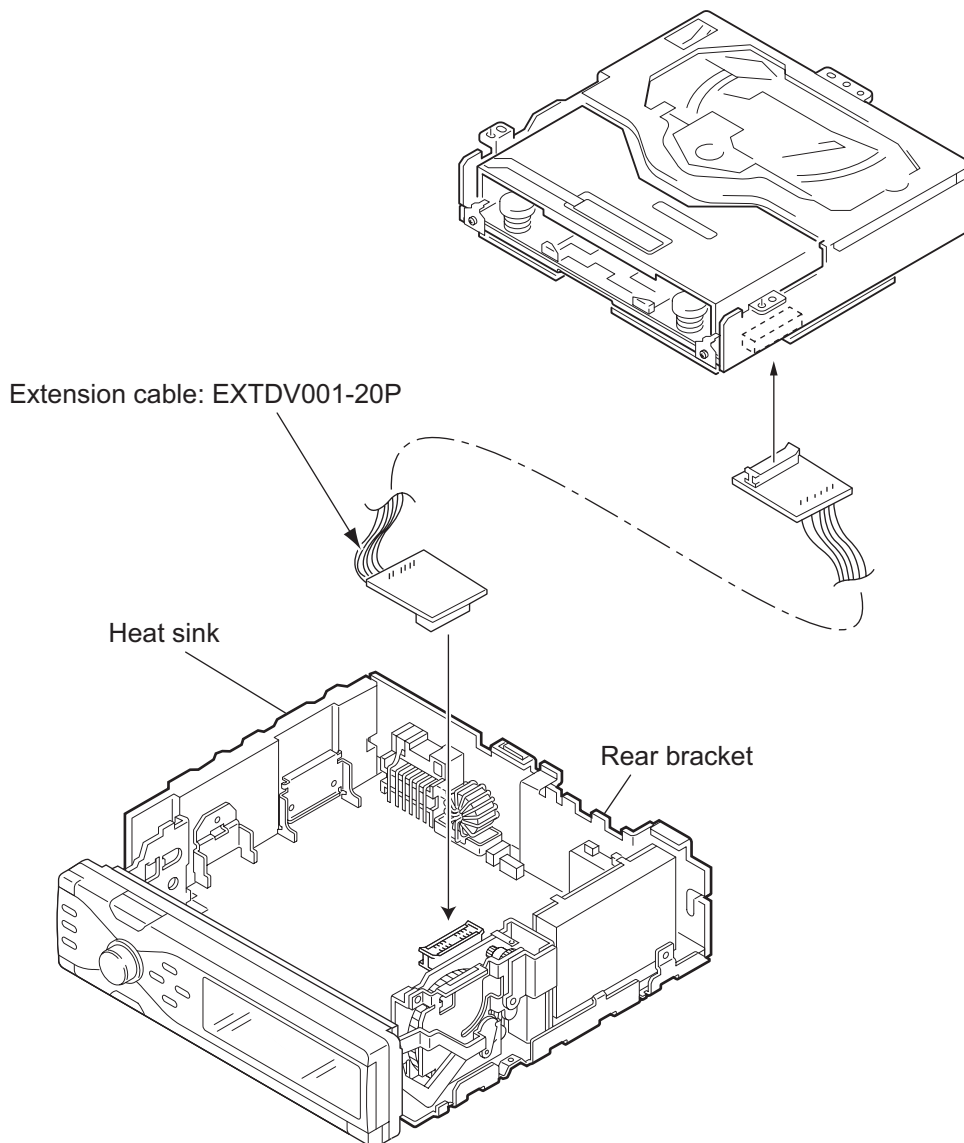

## 4.2 Service mode

### 4.2.1 Service mode setting

- (1) Turn ON power
- (2) Pressing both the DISP button and BAND button.
- (3) Set to service mode
  - CURSOR button ▲ : BACK
  - CURSOR button ▼ : NEXT
  - OK button : SET

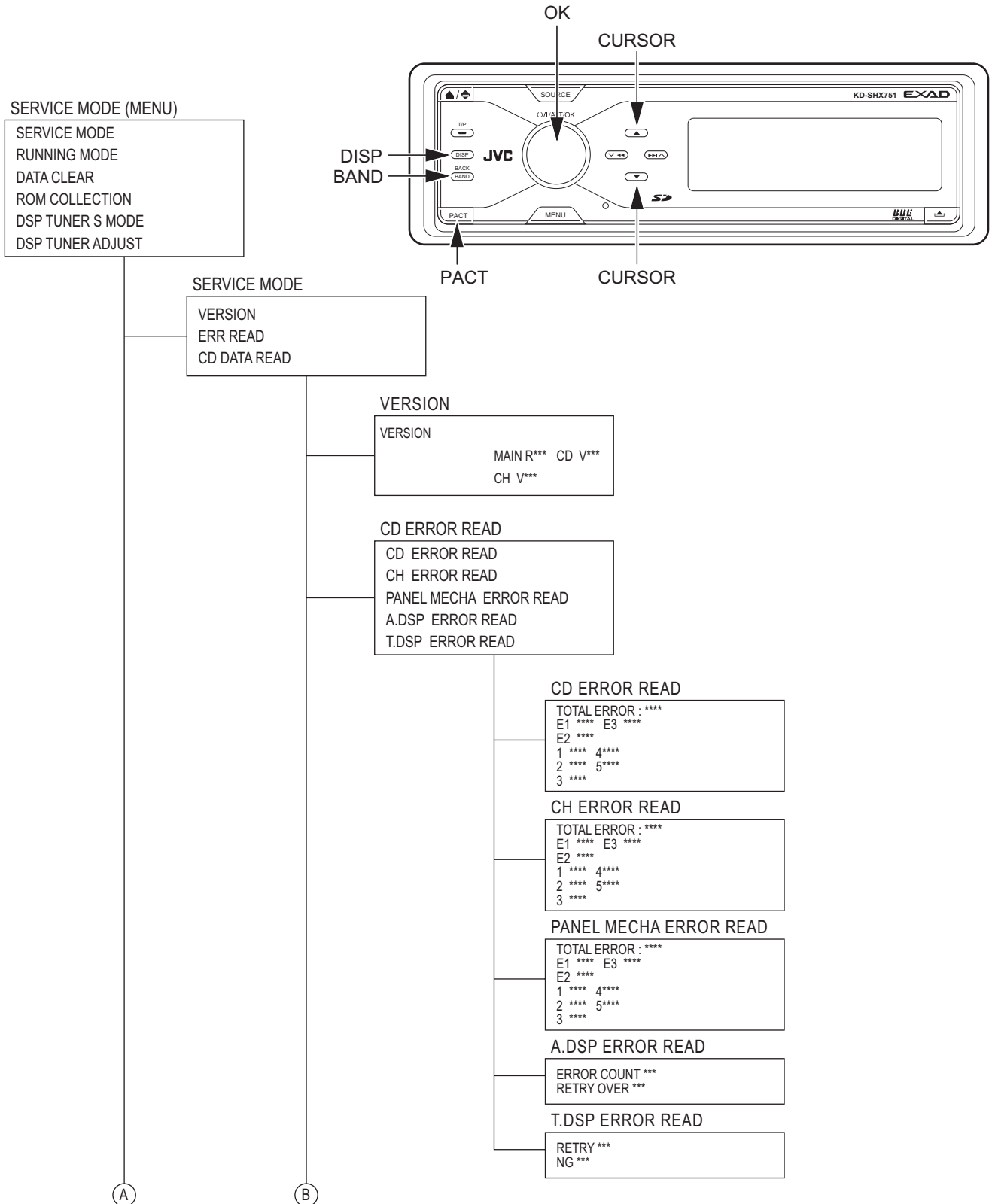

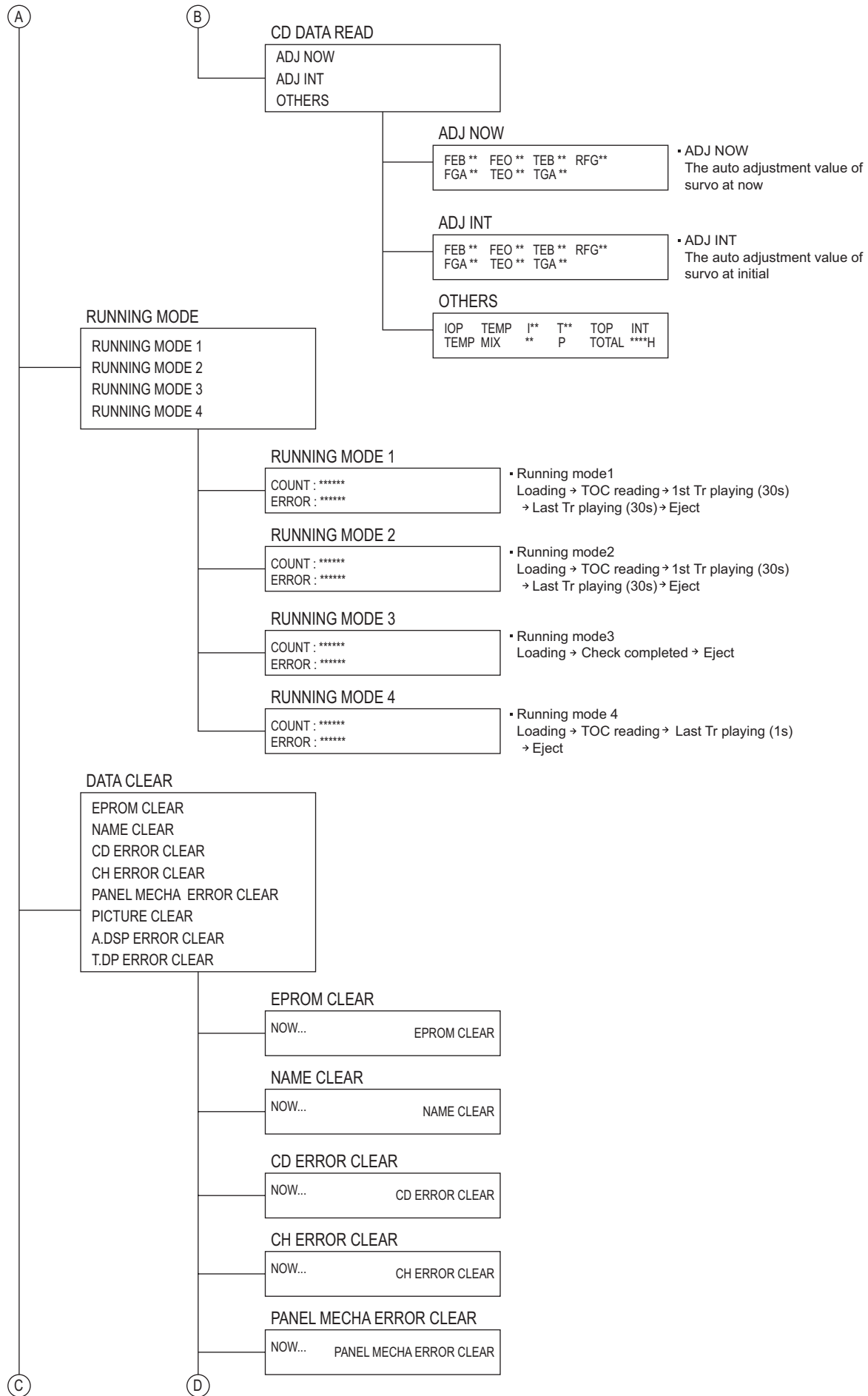



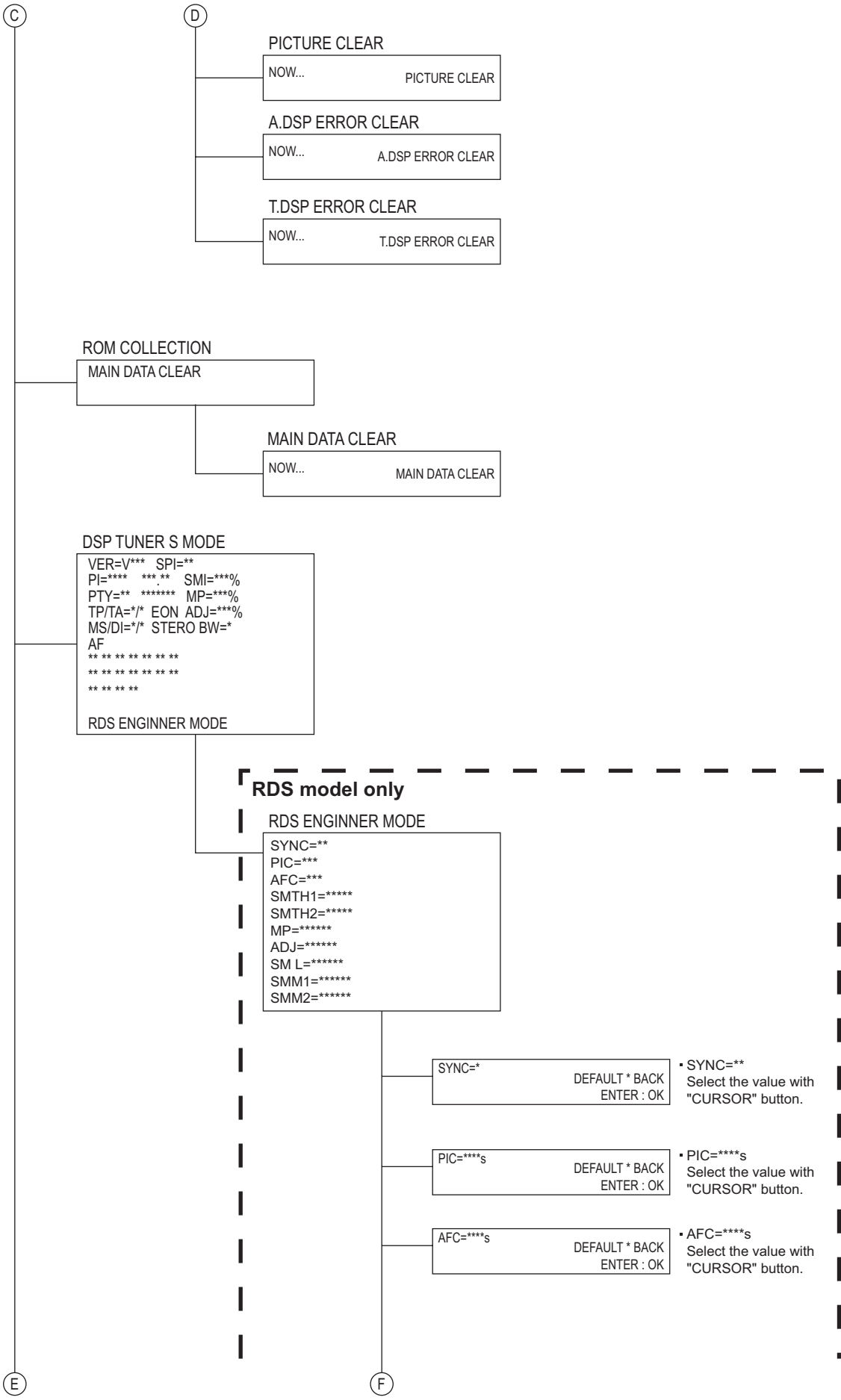

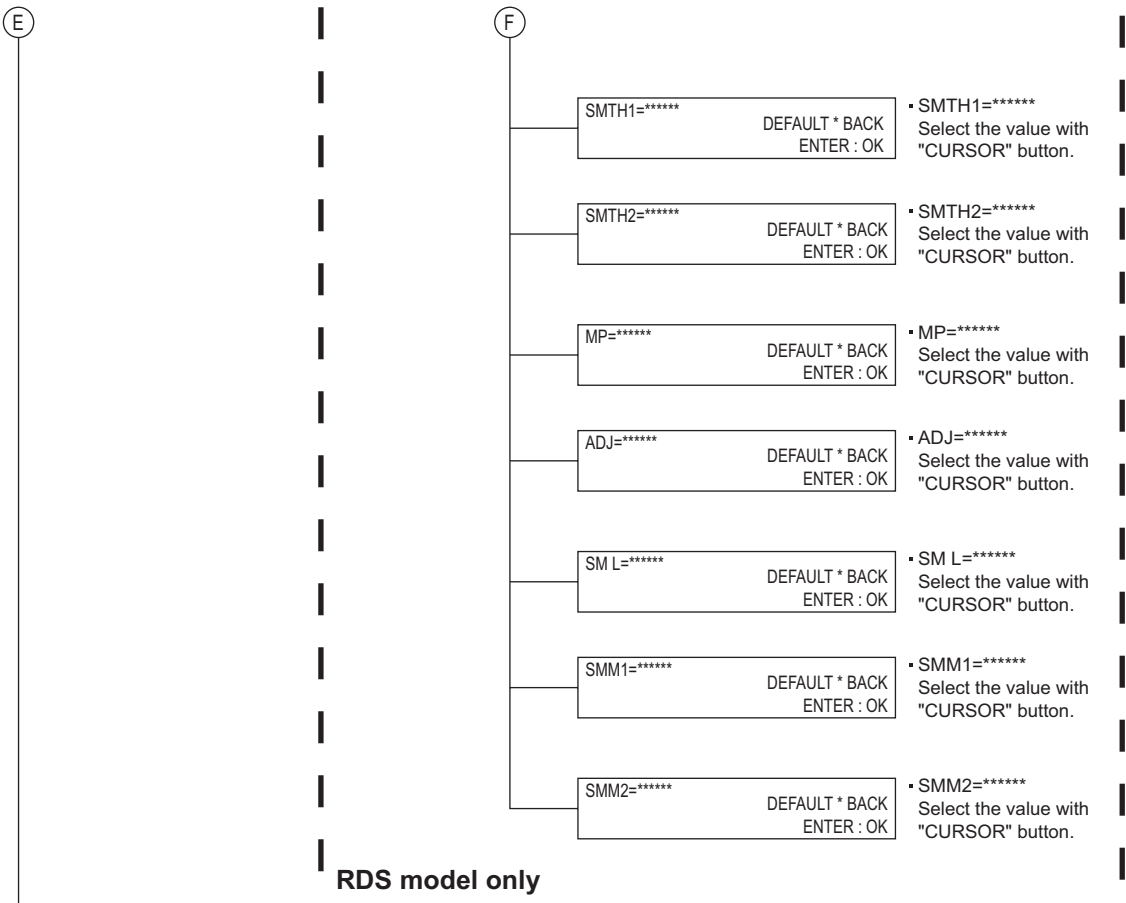



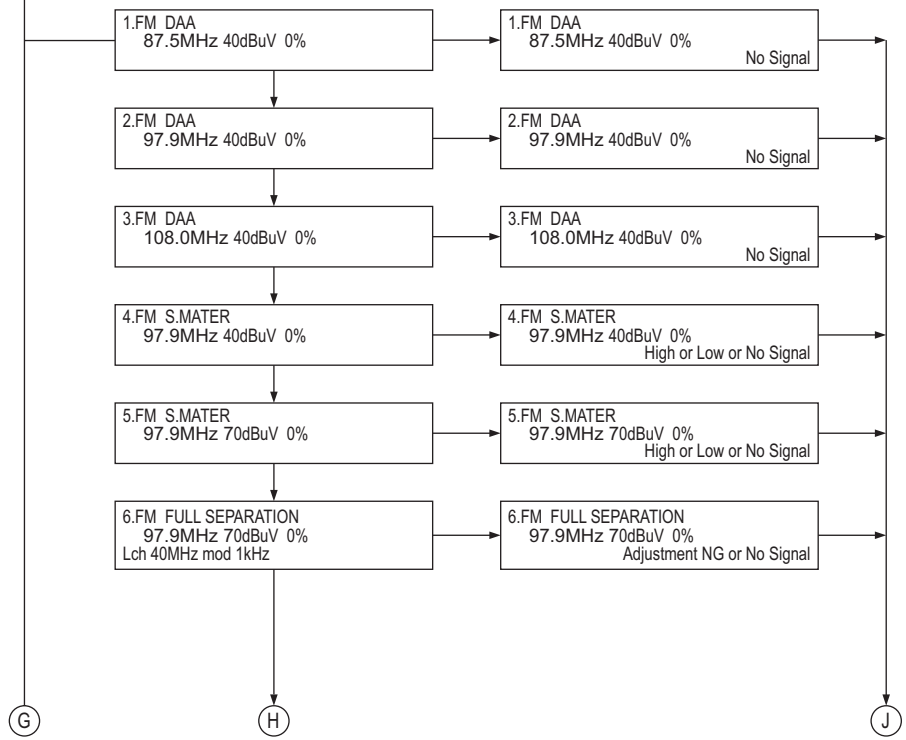

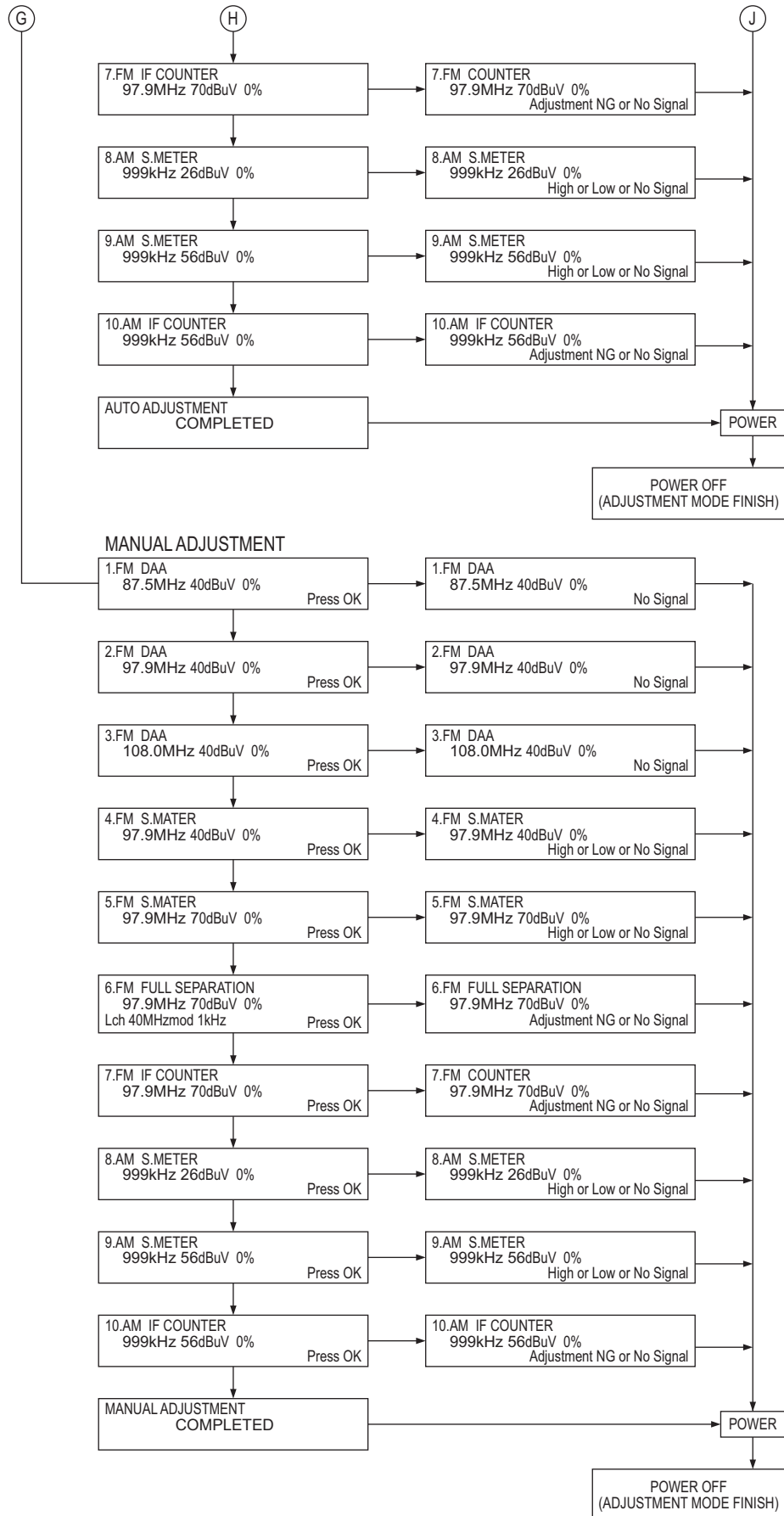
DSP TUNER AJUST  
 AUTO ADJUSTMENT  
 MANUAL ADJUSTMENT



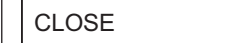
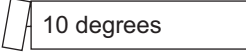

#### 4.2.2 Error code of front panel mechanism

PANEL ANGLE	
1	PANEL  MAIN BODY
2	 10 degrees
3	 20 degrees
4	 30 degrees
OPEN	 OPEN

Details	ERROR CODE (SERVICE MODE)	ERROR CODE (NORMAL)
OPEN error 1.Time out error by OPEN position cannot detect.	0A01	ERR 01
CLOSE error (ANGLE 1 error) 1.Time out error by ANGLE 1 position cannot detect.	0B06	06
Angle positioning error Moving to 10 degrees (ANGLE 2 error) 1.Time out error by ANGLE 2 position cannot detect at moving to open position. 2. Missing to ANGLE 1 and detected ANGLE 2 position at moving to open position. 3.Time out error by ANGLE 2 cannot detect at moving to close position.	0D21 0D22 0D23	21 22 23
Moving to 20 degrees (ANGLE 3 error) 1.Time out error by ANGLE 3 position cannot detect at moving to open position. 2. Missing to ANGLE 2 and detected ANGLE 3 position at moving to open position. 3.Time out error by ANGLE 3 cannot detect at moving to close position.	0E31 0E32 0E33	31 32 33
Moving to 30 degrees (ANGLE 4 error) 1.Time out error by ANGLE 4 position cannot detect at moving to open position. 2. Missing to ANGLE 3 and detected ANGLE 4 position at moving to open position. 3.Time out error by ANGLE 4 cannot detect at moving to close position.	0F41 0F42 0F43	41 42 43
Abnormal switch position at moving panel The panel move to open and close potision,detected abnormal switch position.	0A00	00

## SECTION 5 TROUBLESHOOTING

### 5.1 Feed section

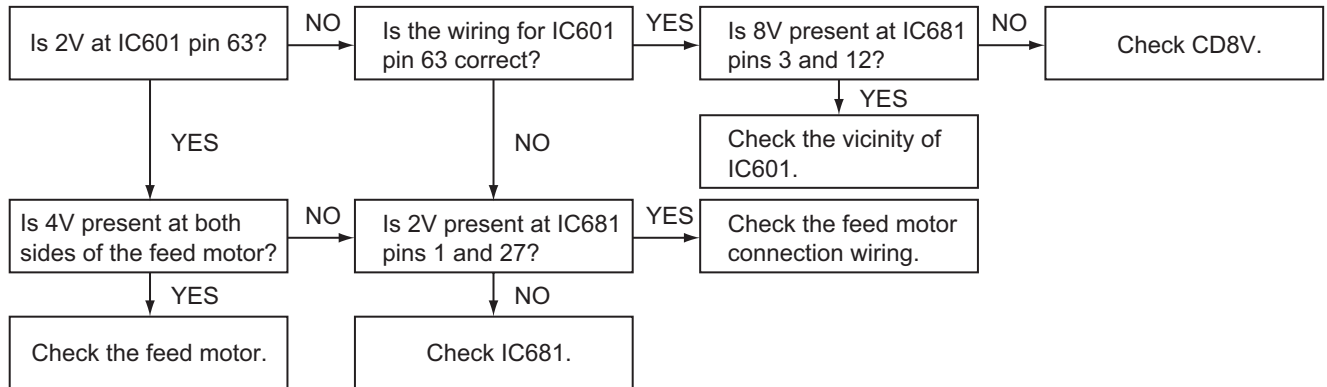

### 5.2 Focus section

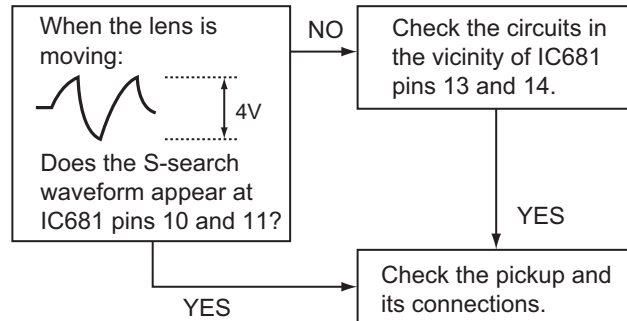

### 5.3 Spindle section

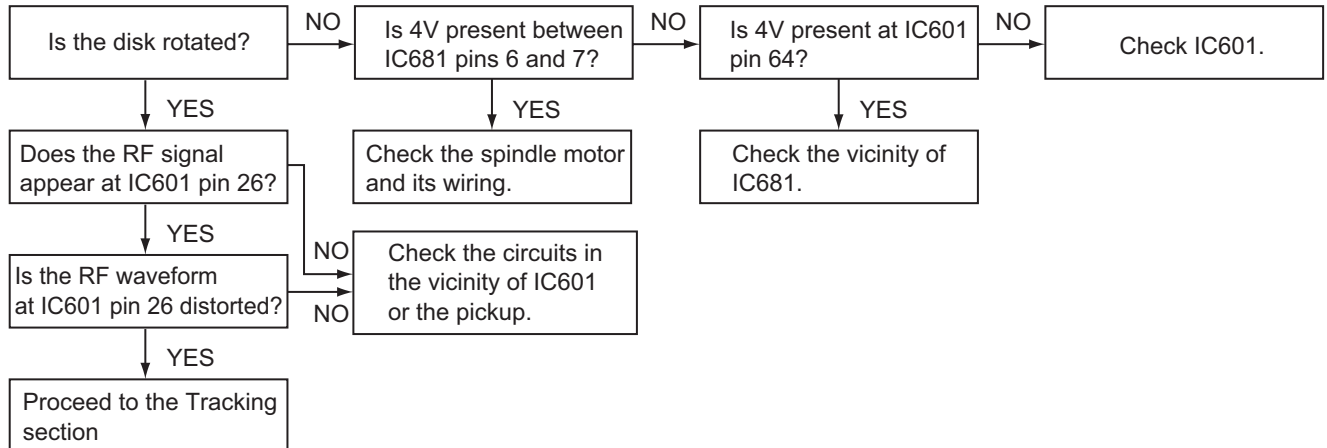

### 5.4 Tracking section

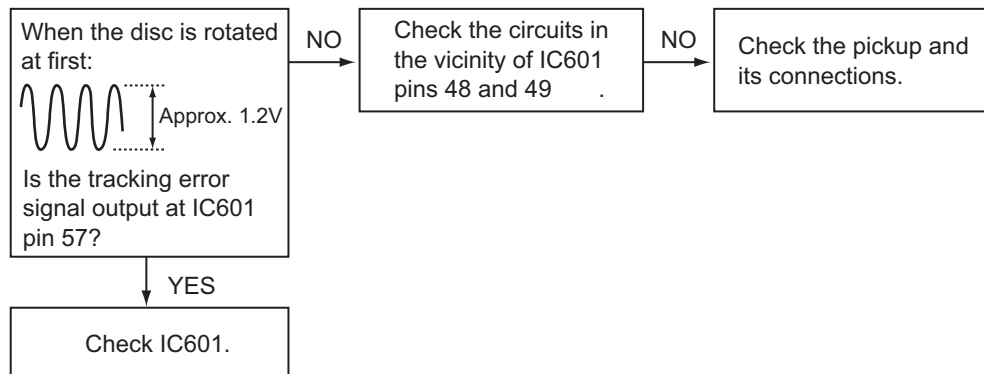

## 5.5 Signal processing section

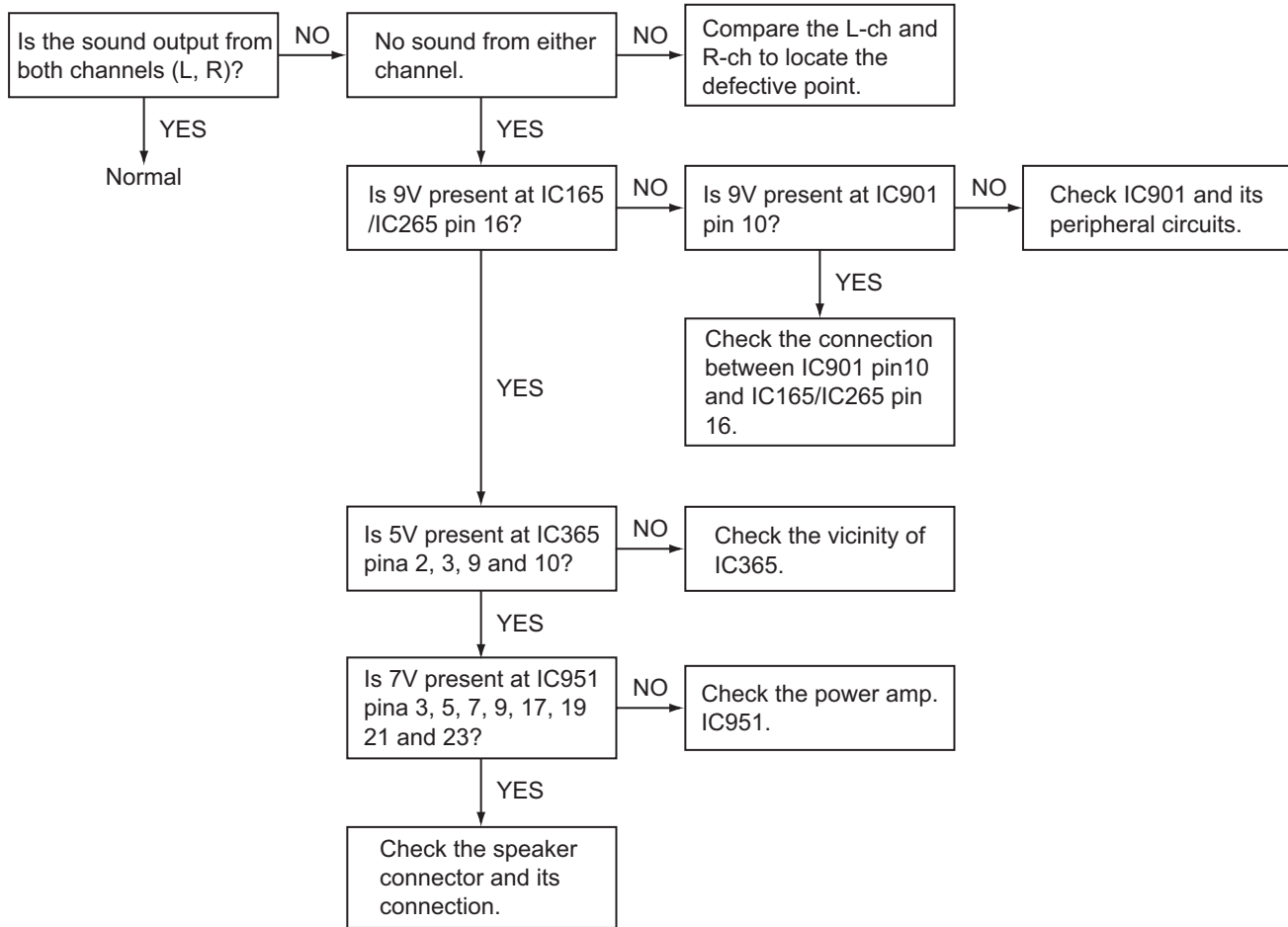

## 5.6 Maintenance of laser pickup

- (1) Cleaning the pick up lens  
Before you replace the pick up, please try to clean the lens with a alcohol soaked cotton swab.
- (2) Life of the laser diode  
When the life of the laser diode has expired, the following symptoms will appear.
  - The level of RF output (EFM output: amplitude of eye pattern) will be low.

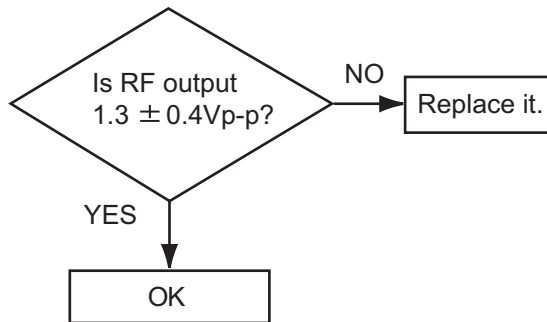

- (3) Semi-fixed resistor on the APC PC board  
The semi-fixed resistor on the APC printed circuit board which is attached to the pickup is used to adjust the laser power. Since this adjustment should be performed to match the characteristics of the whole optical block, do not touch the semi-fixed resistor.  
If the laser power is lower than the specified value, the laser diode is almost worn out, and the laser pickup should be replaced. If the semi-fixed resistor is adjusted while the pickup is functioning normally, the laser pickup may be damaged due to excessive current.

## 5.7 Replacement of laser pickup

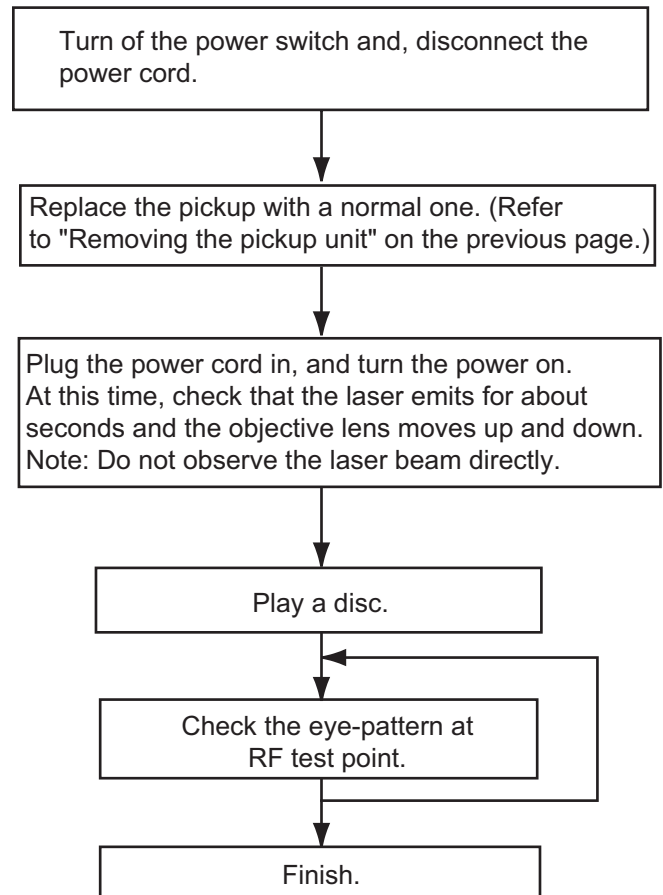

5.8 16 PIN CORD DIAGRAM (for KD-AR8500)

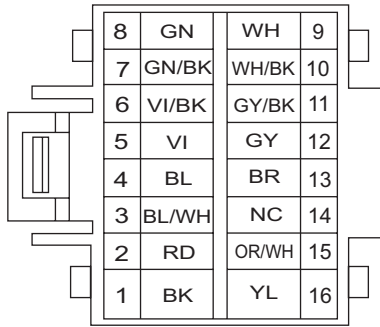

BK	Black	GN	Green
RD	Red	VI	Violet
BL	Blue	GY	Gray
WH	White	YL	Yellow
BR	Brown	OR	Orange

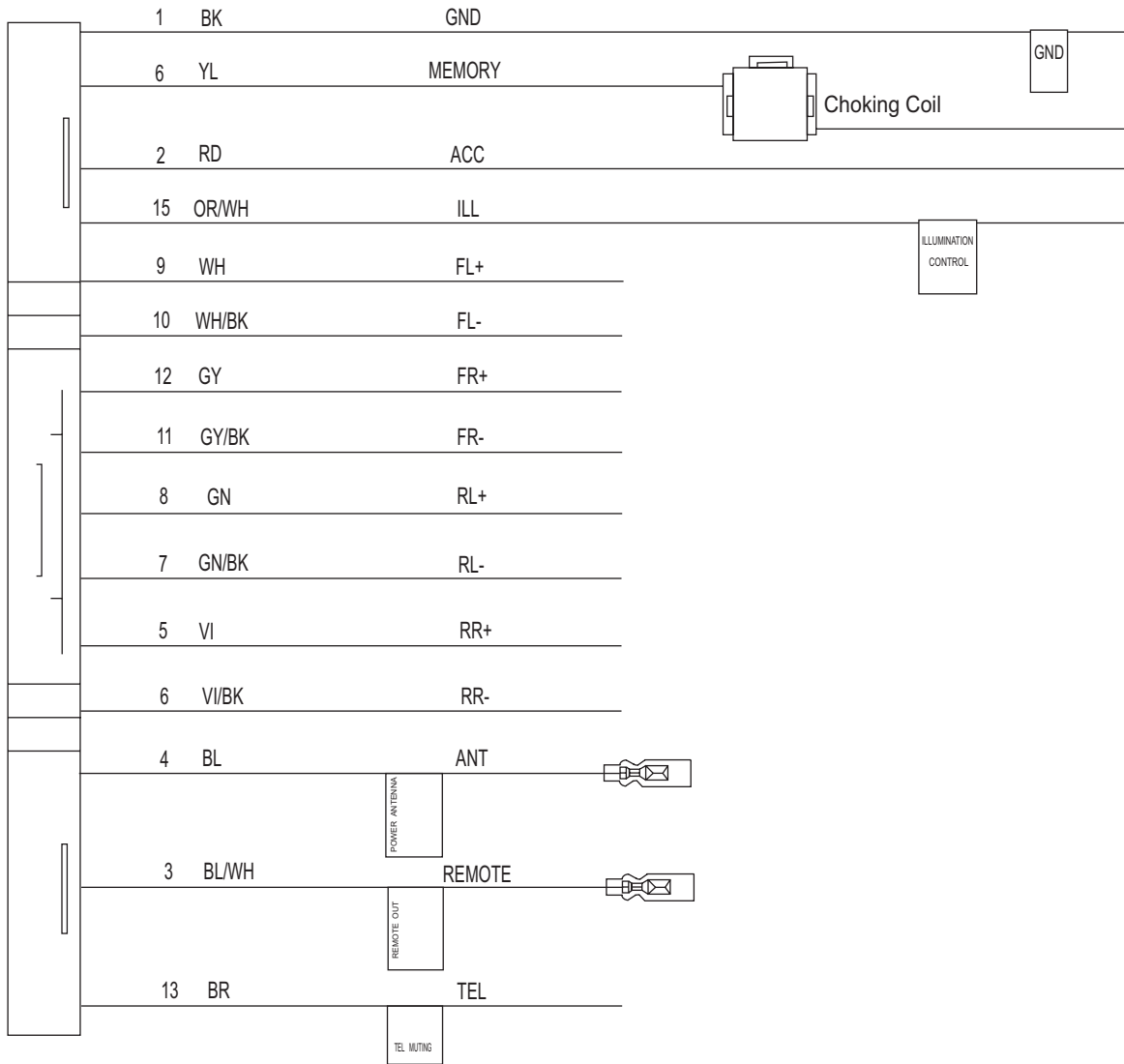

RR	Rear Right	ANT	Auto Antenna
FR	Front Right	ACC	ACC Line
FL	Front Left	ILL	Illuminations Control
RL	Rear Left	GND	Ground
REMOTE	Remote out	MEMORY	Memory Backup Battery+
TEL	Telephone muting		



**5.9 16 PIN CORD DIAGRAM (for KD-SHX850)**

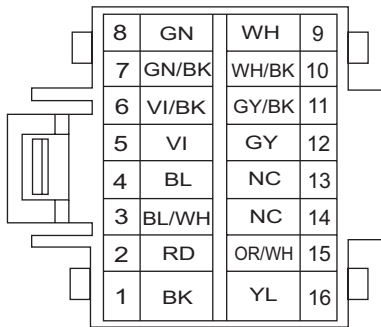

BK	Black	GN	Green
RD	Red	VI	Violet
BL	Blue	GY	Gray
WH	White	YL	Yellow
		OR	Orange

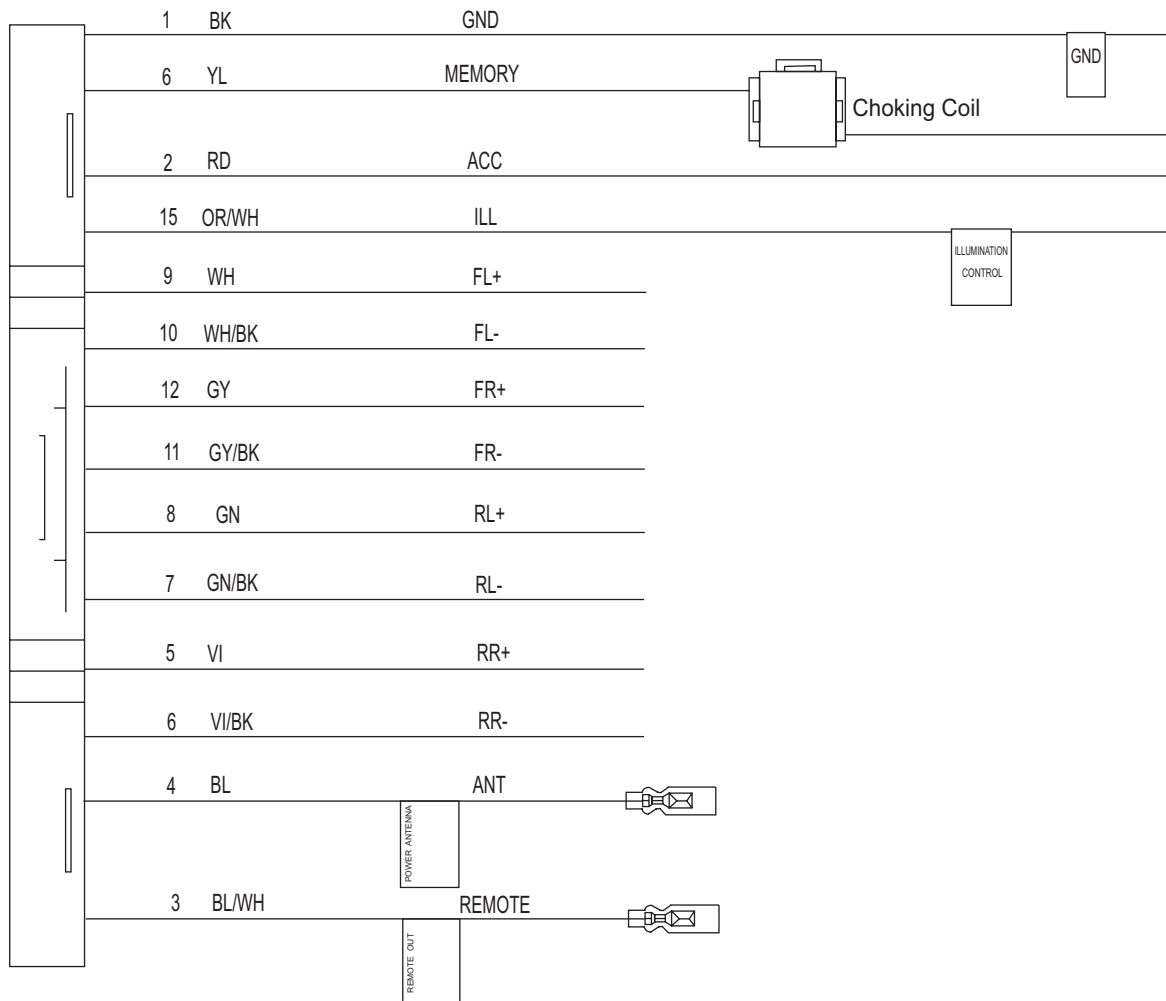

RR	Rear Right	ANT	Auto Antenna
FR	Front Right	ACC	ACC Line
FL	Front Left	ILL	Illuminations Control
RL	Rear Left	GND	Ground
REMOTE	Remote out	MEMORY	Memory Backup Battery+



**JVC**

Victor Company of Japan, Limited  
AV & MULTIMEDIA COMPANY CAR ELECTRONICS CATEGORY 10-1,1chome,Ohwatari-machi,Maebashi-city,371-8543,Japan

(No.MA191)