

# JVC

# SERVICE MANUAL

MODEL

**L-A10**

AUTO-RETURN  
TURNTABLE



# Contents

	Page		Page
1. Specifications . . . . .	1	5. Lubrication . . . . .	4
2. Operation of Automatic Mechanism . . . . .	2	6. Exploded Views and Parts List	
3. Cartridge Replacement . . . . .	2	6-(1) Mechanism Assembly . . . . .	5
4. Adjustment Procedures		Parts List . . . . .	6
4-(1) Overhang Adjustment . . . . .	3	6-(2) Tonearm Assembly . . . . .	7
4-(2) Headshell Angle Adjustment . . . . .	3	6-(3) Mechanism Base . . . . .	7
4-(3) Tonearm Lifter Height Adjustment . . . . .	3	7. L-A10 Schematic Diagrams for Designated Areas . . . . .	8
4-(4) Auto-return (Lead-out) Adjustment . . . . .	3	8. Packing Materials and Part Numbers . . . . .	9
4-(5) Tracking Force Adjustment . . . . .	4	9. Parts List with Specified Numbers for	
4-(6) Anti-skating Adjustment . . . . .	4	Designated Areas . . . . .	10
4-(7) Pulley Height Adjustment . . . . .	4	10. Accessories List . . . . .	Back cover

**Warning:** When replacing the parts marked with  $\triangle$ , be sure to use the designated parts to ensure safety.

## CHECKING YOUR LINE VOLTAGE (For U.S. Military Market and Other Countries)

Before inserting the power plug, please check this setting to see that it corresponds with the line voltage in your area. If it doesn't, be sure to adjust the voltage selector switch to the proper setting before operating this equipment. The voltage selector switch is located the inside chassis.

### CAUTION

Before selecting the "Voltage selector switch" to proper voltage disconnect the power plug.

# 1. Specifications

## MOTOR AND TURNTABLE

Drive System: Belt drive system  
 Drive Motor: 4 poles synchronous motor  
 Speeds: 33-1/3 and 45 rpm  
 Wow and Flutter: Less than 0.075% (DIN)  
 Signal to Noise Ratio: Better than 66 dB (DIN-B)  
 Platter: 12-inch(30cm) diameter die-cast aluminium alloy

Optimum Tracking Force: DT-38  
 2.0  $\pm$  0.5 grams  
 Output: 2.5mV (1kHz)  
 Frequency Responce: 10 to 20,000Hz  
 Separation: Better than 25dB (1kHz)  
 Load Resistance: 47k ohms  
 Compliance: 25 x 10<sup>-6</sup> cm/dyne

## TONARM

Type: Statically-balanced straight tubular arm with tracking force dial of 0.1 gram steps  
 Effective Arm Length: 220mm  
 Overhang: 15mm  
 Applicable Tracking Force Range: 0 to 3 grams

## FEATURES

Tonearm lifter, Auto-return mechanism, Removable dust cover, Anti-skating device, etc.

## GENERAL

Power Source: See page 8  
 Power Consumption: See page 8  
 Dimensions: 42 x 35 x 11.5cm (W x D x H)  
 (16.5 x 14 x 4.5 inch)  
 Weight (Net): 4.5kg (9.9 lbs)

## CARTRIDGE (EXCEPT FOR U.S.A)

Type: Dual magnet, MD1038  
 Stylus: 0.6 mil diamond, DT-38 or ATN-3410 By AUDIO-TECHNICA

## 2. Operation of Automatic Mechanism

### Change cycle mechanism:

1. During playing, the notch of the main gear position relative to the turntable spindle gear is as shown in Fig. 1. As the projection is away from the engagement, the main gear does not rotate even though the turntable.
2. As playing proceeds, the trip slide moves toward the center of the turntable following the movement of the tonearm.
3. The engagement is very easy to move as it simply rests on the lower trip. On the music section of the record groove the engagement moves so slightly that it is returned by the tip of the projection. Consequently, the turntable spindle gear does not engage with the main gear and thus does not trigger the auto-return operation as shown in Fig. 2.
4. When playing ends and the pick-up cartridge enters the lead-out groove which is spaced out, the engagement advances more than it is returned by the projection. Because of this, the engagement is pressed by the projection as shown in Fig. 3, causing the main gear to turn and engage with the turntable spindle gear. Thus the change cycle is started.
5. During the return operation the engagement and lower trip which have moved are returned to their original position by the reject button coming into contact with the bottom of the lower trip. At this moment the switch lever operates with the help of the main gear cam, switching off the power just before the rotation should stop. This completes the automatic cycle.

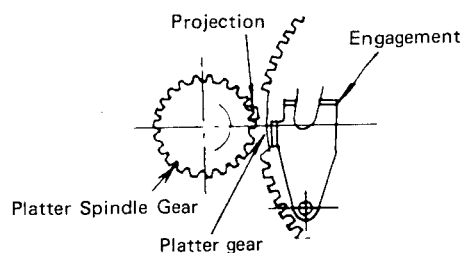

Fig. 1

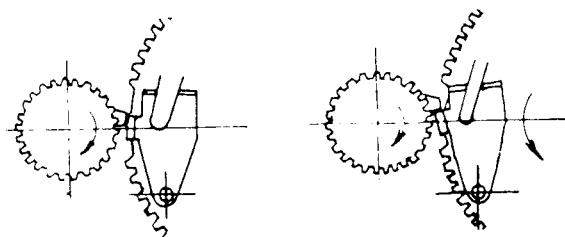

Fig. 2

Fig. 3

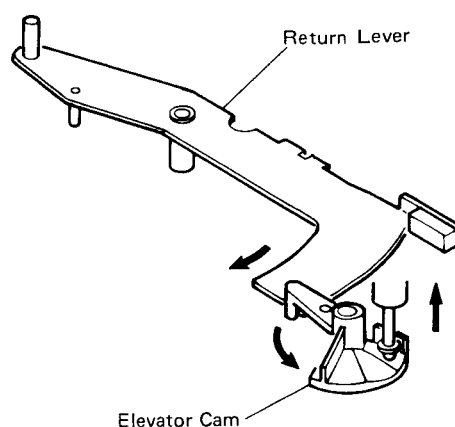

Fig. 4

### Tonearm lift and return mechanism:

1. When the main gear starts to rotate at the end of playing, the return lever rotates under the action of the main gear cam to press the elevator cam. The upward movement of the elevator cam is directly converted into movement of the elevator, lifting up the tonearm. (Fig. 4)
2. The tonearm is returned by the arm lever the end of which presses it as the main gear rotates.

## 3. Cartridge Replacement

1. Unscrew the connector screw to remove the headshell.
2. Remove the two long screws on the headshell which hold the cartridge. (Fig. 5)
3. Connect the lead wires of the headshell to the new cartridge, being careful to match the polarities correctly. Polarity and wire colors are as follows:
 

White (+)	.....L	Red (+)	.....R
Blue (-)	.....LE	Green (-)	.....RE
4. Attach the cartridge to the headshell squarely, and gently tighten the screws.
5. Set the cueing button to "DOWN", and then bring the stylus tip to the optimum position by sliding the cartridge back and forth. See 4-(1) Overhang Adjustment.
6. After attaching the cartridge, slide the headshell into the tonearm. Tighten the connector screw.
7. Be sure to adjust the tracking force and lead-in position after replacing the cartridge.

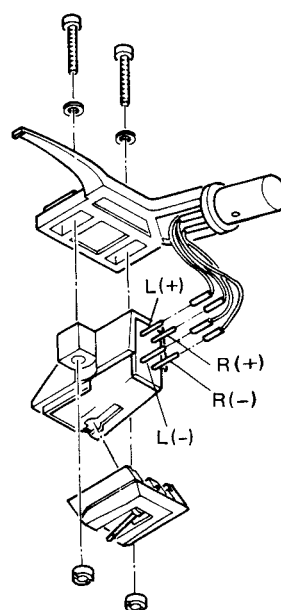

Fig. 5

## 4. Adjustment Procedures

The following adjustments should be performed only when replacing a cartridge or a headshell. Otherwise, no adjustment is required.

If necessary to replace a cartridge, usage of that headshell exclusive to this unit is recommended.

### 4-(1) Overhang Adjustment

To obtain optimum overhang, when mounting the cartridge, first align the cartridge's longitudinal axis with that of the headshell and position the cartridge so that the distance between the headshell's end face and the stylus tip equals 32mm as shown in Fig. 6.

Be sure to tighten the set screw after the adjustment. Errors within 1mm are negligible from a practical point of view.

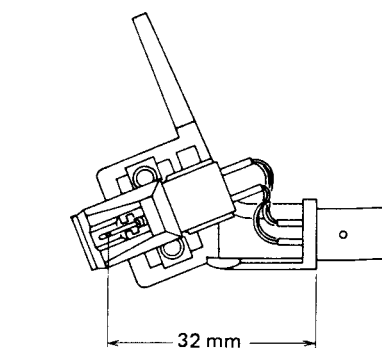

Fig. 6

### 4-(2) Headshell Angle Adjustment

If the headshell is not horizontal and the stylus tip is not perpendicular to the record surface, loosen the lock screws using a small screwdriver and adjust the headshell until the stylus tip is set at a right angle as shown in Fig. 7. Eye measurement is sufficient.

Be sure to retighten the screws after the adjustment is completed.

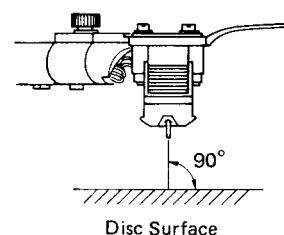
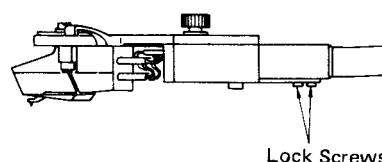

Fig. 7

### 4-(3) Tonearm Lifter Height Adjustment

Adjust the height of tonearm lifter with the adjustment screw so that the distance between the stylus tip and the surface of record is about 6mm when the stylus is elevated. Turn the height adjustment screw clockwise to lower, and counterclockwise to raise the tonearm lifter level. (See Fig. 8.)

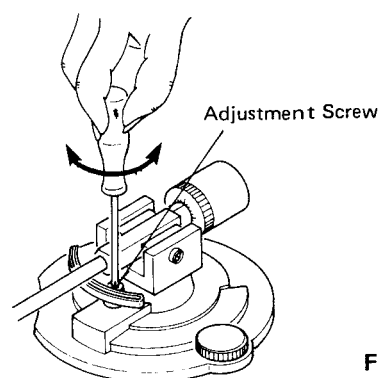

Fig. 8

### 4-(4) Auto-return (Lead-out) Adjustment

When the pulley has been replaced for a different record or if auto-return functions early, adjust as shown in Fig. 9

- When change cycle starts too late, turn the screw counterclockwise with a screwdriver.
- When change cycle starts too early, turn the screw clockwise.

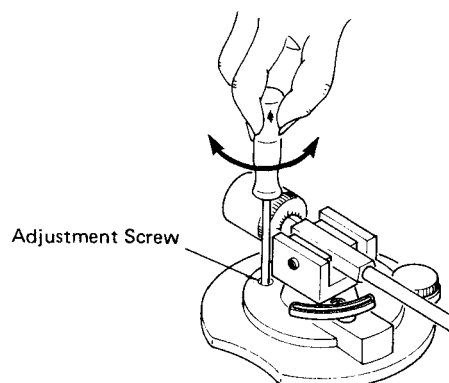

Fig. 9

## 4-(5) Tracking Force Adjustment

1. Set the anti-skating knob to the "0" mark on the dial.
2. Place an unwarped disc onto the platter.
3. Remove the stylus cover from the stylus.
4. Release the tonearm clamp.
5. Turn the counterweight until the tonearm is balanced.
6. Stop turning the counterweight when the stylus tip is almost touching the disc surface.
7. Return the tonearm to the rest and clamp it.
8. Hold the counterweight at the adjusted position and turn the tracking force dial until the "0" mark is aligned with the index line on the tonearm weight shaft. Turn the counterweight in the A direction until the "2.0" mark on the dial is aligned with the index line.

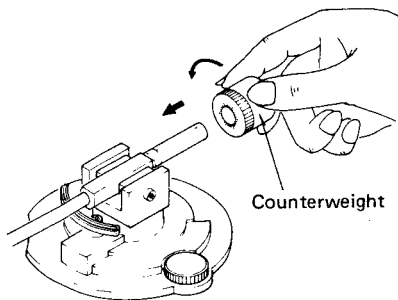

Fig. 10-A

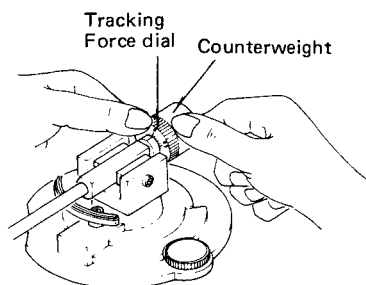

Fig. 10-B

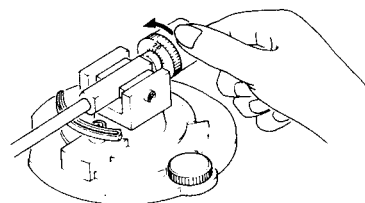

Fig. 10-C

## 4-(6) Anti-skating Adjustment

Adjust the anti-skating force according to the cartridge used. Turn the anti-skating knob dial to the same number on the tracking force dial.

Set the "2" of the Knob dial to the index Arrow since the L-A10 is provided with a spherical stylus except U.S.A.

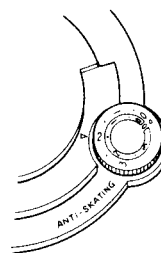

Fig. 11

## 4-(7) Pulley Height Adjustment

When the pulley has been replaced for a different frequency, adjust the height of the pulley so that the belt is located in the middle of each section. If this is not done its correct speeds cannot be obtained and the speed change will not be smooth.

If the belt is in contact with the shift lever, the height of the pulley is not correct. Loosen the set screw and adjust the pulley vertically. (Fig. 12)

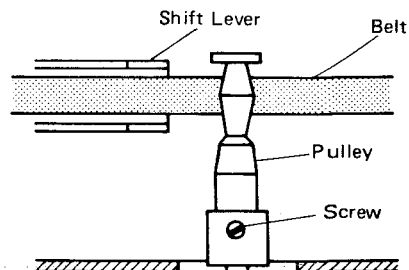

Fig. 12

## 5. Lubrication

Use quality mineral oil such as sewing machine oil on the motor shaft and turntable spindle.

\* Motor shaft

5 - 6 drops once a month for heavy use.

1 - 2 drops every three months for normal home use.

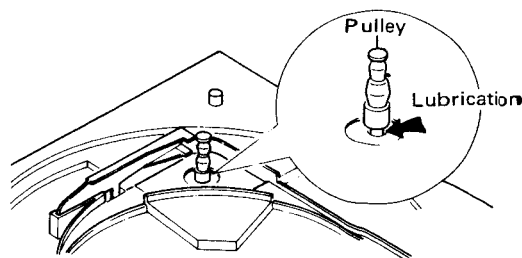

Fig. 13

# 6. Exploded Views and Parts List

## 6-(1) Mechanism Assembly

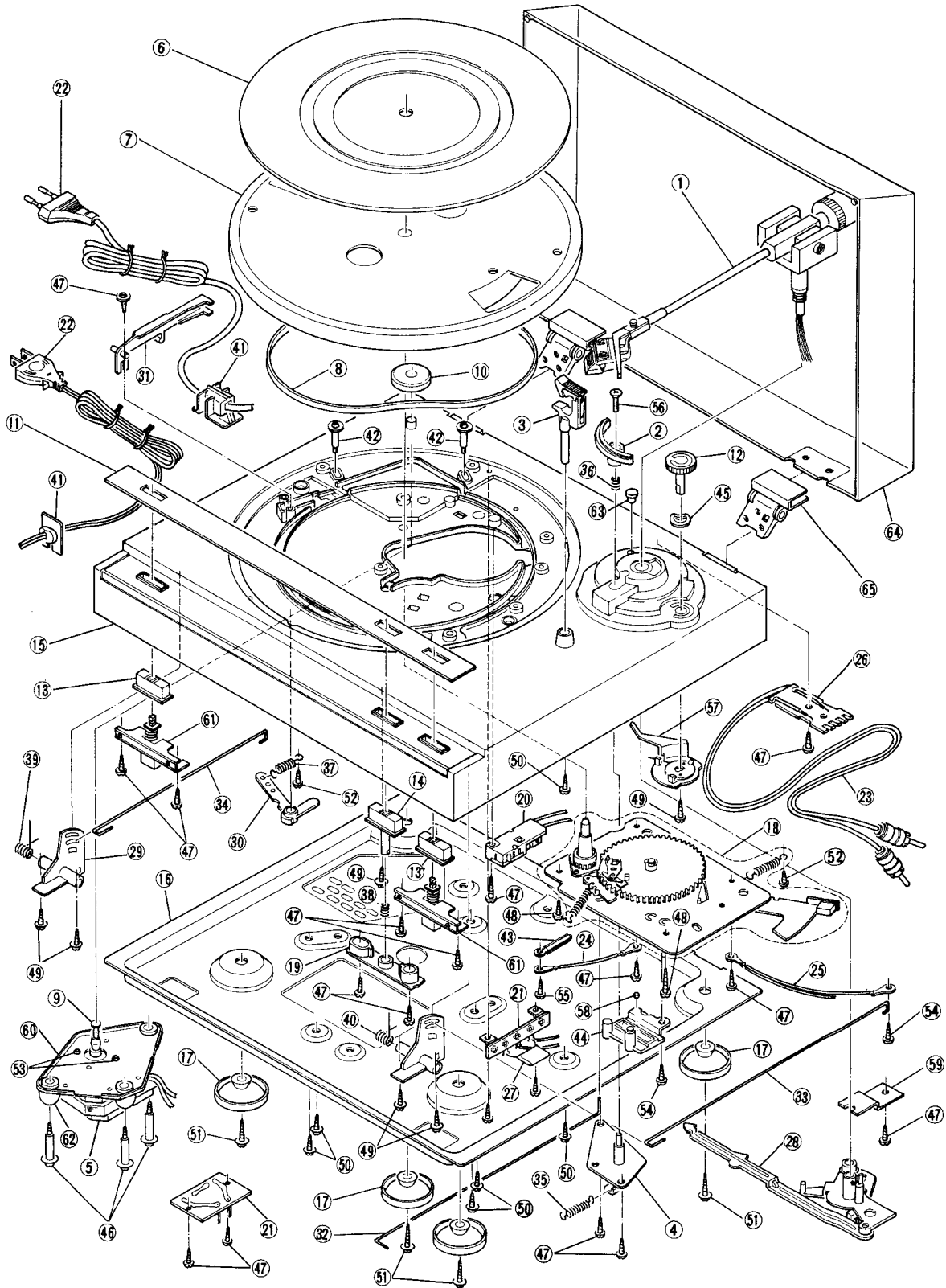

Fig. 14

**Parts List**

No.	Parts No.	Parts Name	Q'ty
1	See page 7 (Fig. 15)	Tone Arm Ass'y	1
2	E65769-001	Elevator Ass'y	1
3	E65824-003	Rest Ass'y	1
4	E67313-002	Cueing Ass'y	1
5	See page 10	Motor	1
6	See page 10	Turntable covering	1
7	E1971-005	Turntable	1
8	E301437-002	Belt	1
9	See page 10	Pulley	1
10	E66329-001	EP Adaptor	1
11	E23801-002	Ornament	1
12	E301238-001	Anti Skating Knob	1
13	E301241-003	Knob	2
14	E67704-002	Knob	1
15	See page 10	Cabinet	1
16	E10556-002	Bottom Board	1
17	See page 10	Foot Ass'y	4
18	See page 7 (Fig. 16)	Mech. Base Ass'y	1
19	E67708-001	Knob Base	1
20	See page 10	Micro Switch	1
21	See page 10	Lug Strip Ass'y	1
21-2	See page 10	Circuit Board Ass'y	
22	See page 10	Power Cord	1
23	E03697-003	Signal Cord	1
24	EWT021-001	Terminal Wire Ass'y	1
25	EWT042-005	Terminal Wire Ass'y	1
26	E67761-001	Signal C.B. Ass'y	1
27	See page 10	Capacitor	1
28	E300271-004	Arm Lever Ass'y	1
29	E301242-001	Lever	2
30	E61094-002	Shifter Lever	1
31	E61473-003	Shifter	1
32	E67706-001	Rod	1

No.	Parts No.	Parts Name	Q'ty
33	E67712-001	Rod	1
34	E67712-002	Rod	1
35	E49596-001	Spring	1
36	E49649-001	Spring	1
37	E65251-002	Spring	1
38	E67063-002	Spring	1
39	E67692-003	Spring	1
40	E67692-003	Spring	1
41	See page 10	Cord Stopper	1
42	E49633-003	Motor Holder	2
43	E50670-005	Wire Clamp	1
44	E30154-001	Ball Holder	1
45	E49602-004	Wave Washer	1
46	E61530-001	Screw	3
47	E65921-002	Tapping Screw	15
48	E65921-005	Tapping Screw	2
49	E65922-002	Tapping Screw	7
50	E65922-004	Tapping Screw	6
51	E65923-002	Screw	4
52	E65922-004	Screw	2
53	LPSP3008ZS	Screw	2
54	SBSB3008Z	Screw	2
55	SBSB3016Z	Screw	1
56	SSSP3016M	Screw	1
57	E67690-001	Anti Skating	1
58	G41505-1	Steel Ball	1
59	E67691-001	Stoper	1
60	E67707-001	Mounting Plate	1
61	E03820-004	Push SW.	2
62	E49631-003	Rubber Bushing	3
63	See page 10	Mask Cap	1
64	E23680-001	Dust Cover	1
65	E69354-001	Hinge Ass'y	2

## 6-(2) Tonearm Assembly

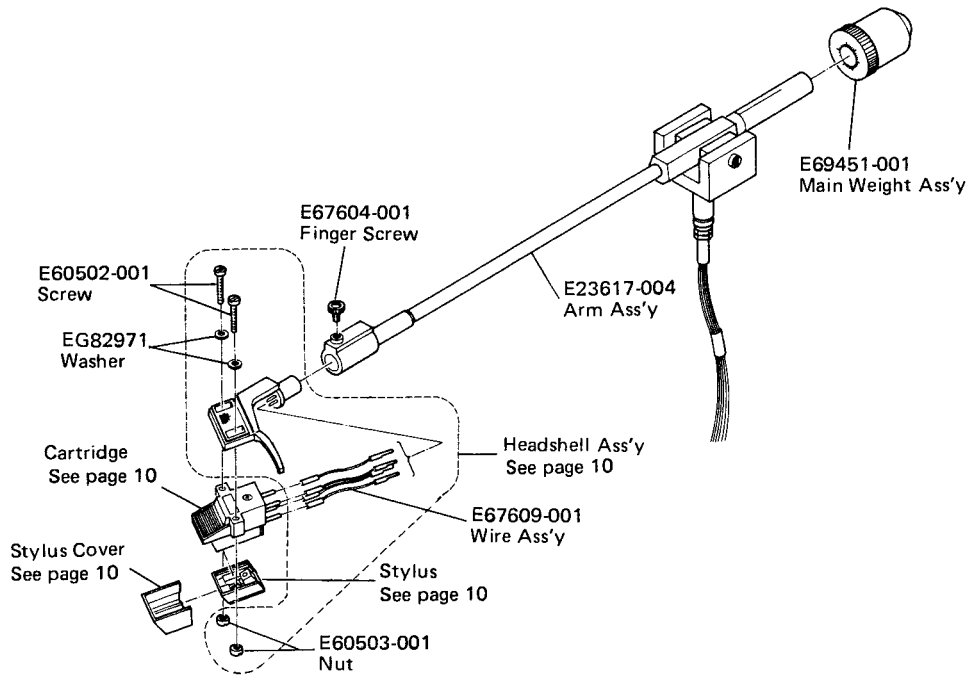

Fig. 15

## 6-(3) Mechanism Base

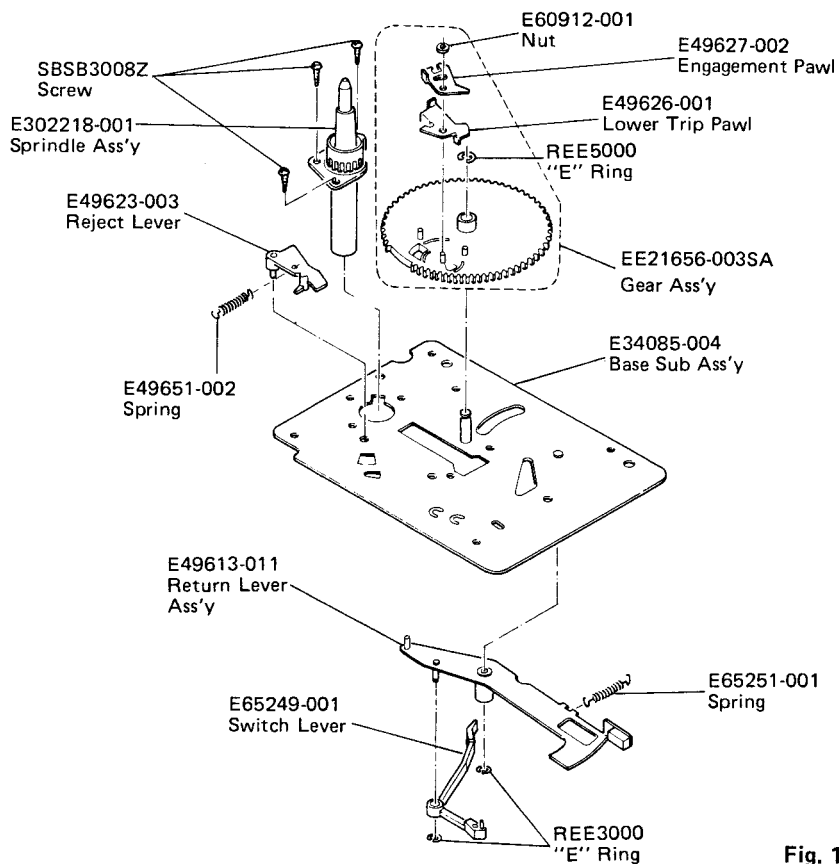

Fig. 16



# 7. L-A10 Schematic Diagrams for Designated Areas

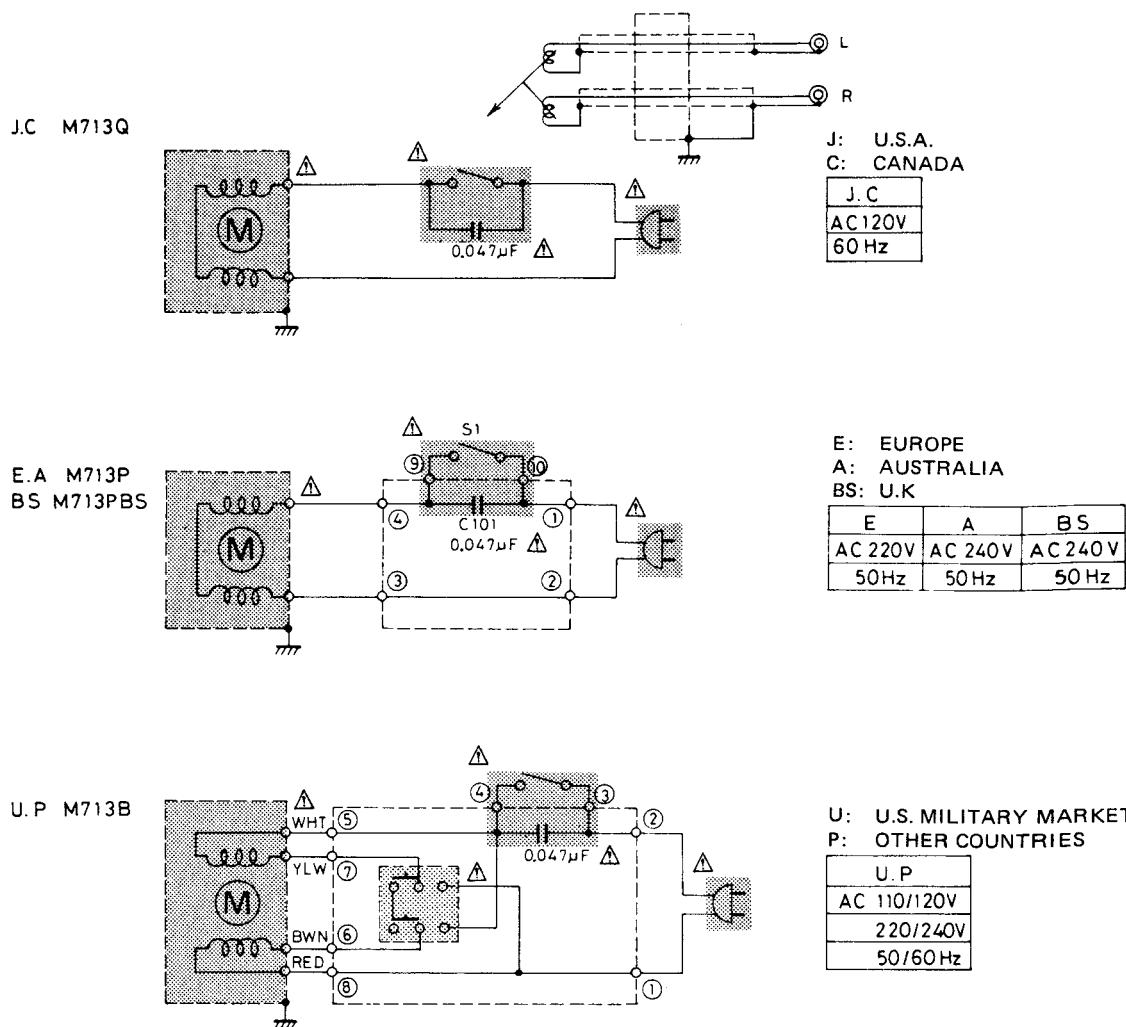

Fig. 18

Note:  $\Delta$  Safety Parts  
Ensure Safety and Radio Interference

## POWER SPECIFICATIONS

Countries	Line Voltage & Frequency	Power Consumption
U.S.A., CANADA	AC 120V, 60Hz	13 watts
EUROPE CONTINENT	AC 220V~, 50Hz	13 watts
U.K., AUSTRALIA	AC 240V~, 50Hz	13 watts
U.S. MILITARY MARKET	AC 110~120V/220~240V Selectable, 50/60Hz	13 watts
OTHER AREAS	AC 110~120V/220~240V Selectable, 50/60Hz	13 watts

## 8. Packing Materials and Part Numbers

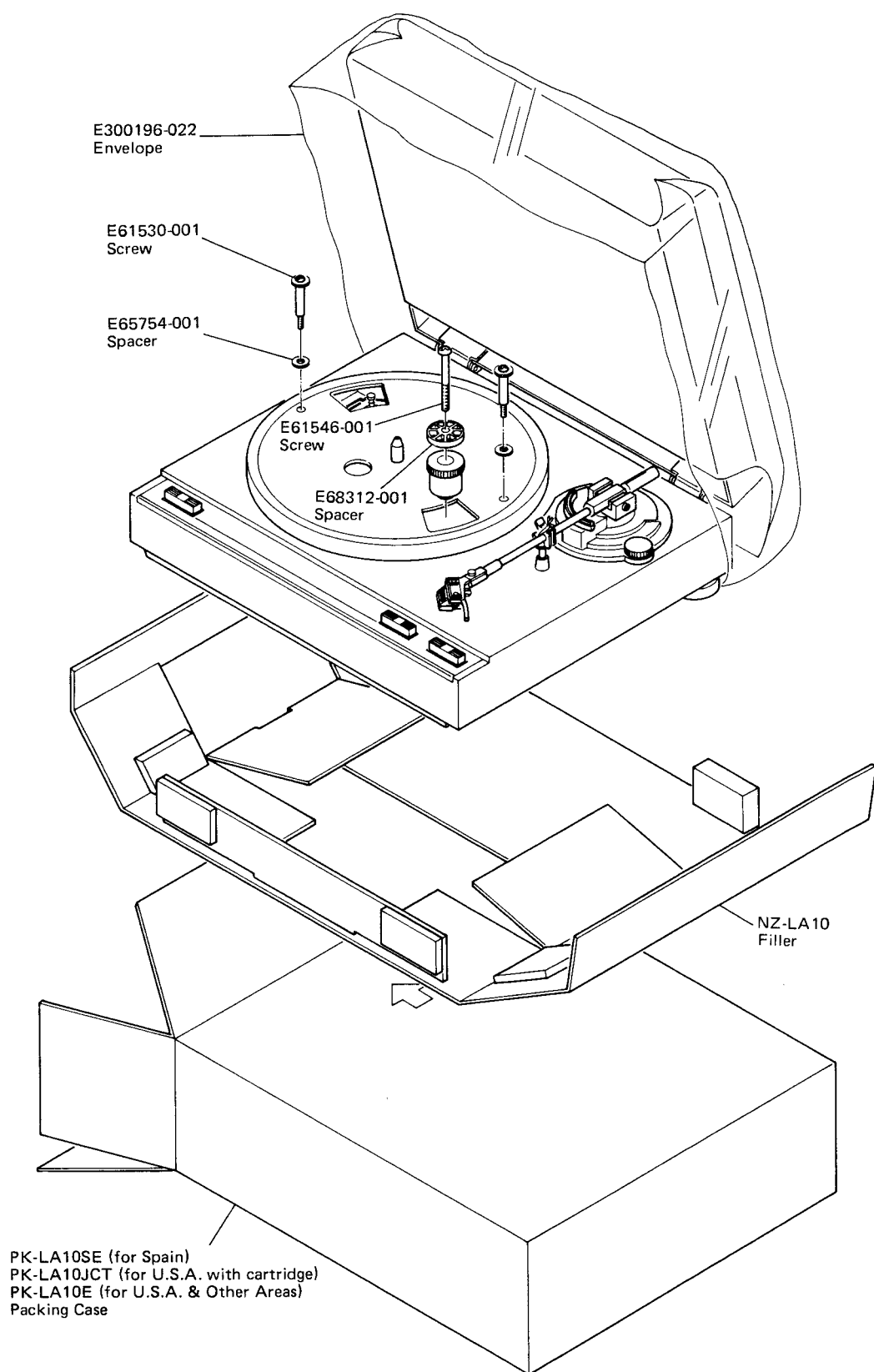

Fig. 17

## 9. Parts List with Specified Numbers for Designated Area

Item No.	Description	U.S.A. (& Canada)	U.S. Military Market & Other Countries	Europe	Australia	U.K.
1	*Tonearm Ass'y	ARM-545 (MP 331S)	MP-331S	MP-331S	MP-331S	MP-331S
5	Motor $\triangle$	M713Q	M713B	M713P	M713P	M713PBS
6	Turntable Covering	E23644-002	E23644-001	E23644-001	E23644-001	E23644-001
9	Pulley (50Hz)	—	E68302-001	E68302-001	E68302-001	E68302-001
	" (60Hz)	E68302-002	E68302-002	—	—	—
15	Cabinet	E10554-003	E10554-004	E10554-004	E10554-004	E10554-004
17	Foot Ass'y	E35857-003	E35857-005	E35857-005	E35857-005	E35857-005
20	Micro SW $\triangle$	QSM1V12-106	QSM1V12-106	QSM1V12-105	QSM1V12-105	QSM1V12-105BS
21	Lug Strip Ass'y $\triangle$	E65274-002	—	—	—	—
21-2	Cir. B. Ass'y $\triangle$	—	TPS-208	TPS-207B	TPS207B	TPS-207BBS
22	Power Cord $\triangle$	QMP1200-200	QMP7600-250	QMP3900-200	QMP2560-244	QMP9017-008BS
27	Capacitor	QFH72BM-473M (QFA72BM-473)	QFH53BM-473	QFZ9007-473	QFZ9007-473	QFZ9007-473BS
41	Cord Stopper $\triangle$ (Cord S. Plate)	QHS3876-162 (E65465-001)	A37897	A37897	A37897	A37897BS
63	Mask Cap	E65395-002	—	—	—	—

	Cartridge Body	— (MD 1038Z)	MD 1038Z	MD 1038Z	MD 1038Z	MD 1038Z
	Stylus	— (DT-38)	DT-38	DT-38	DT-38	DT-38
	Stylus Cover	— (E301614-001)	E301614-001	E301614-001	E301614-001	E-301614-001
	Headshell Ass'y	E301201-008	E301201-008	E301201-008	E301201-008	E301201-008

Note:  $\triangle$  SAFETY PARTS

\* See Fig. 15 when placing an order.

# 10. Accessories List

Item No.	Description	U.S.A. (& Canada)	U.S. Military Market & Other Countries	Europe	Australia	U.K.
1	Instruction Book	E30580-1002A	E30580-1002A	E30580-1002A	E30580-1002A	E30580-1002ABS
2	Warranty Card	BT20047 (BT20025E)	BT20047 (U.S. Military only)	—	BT20029C	BT20013C
3	Does it Better	BT20046A	BT20046A (U.S. Military only)	—	—	—
4	Inst. Sheet	—	E301620-001	—	—	—
5	E.P. Adaptor	E66329-001	E66329-001	E66329-001	E66329-001	E66329-001
6	Screw Driver	—	E45557-003	—	—	—
7	Siemens Plug	—	E04056 (Other Countries only)	—	—	—
8	Envelope (Inst. Book)	E300196-010	E300196-010	E300196-010	E300196-010	E300196-010
9	Envelope (Turntable Covering)	E300196-023	E300196-023	E300196-023	E300196-023	E300196-023
10	Safety Inst.	BT20044B	—	—	—	—

# JVC

VICTOR COMPANY OF JAPAN, LIMITED, TOKYO, JAPAN