

DIRECT-DRIVE TURNTABLE

PD-121/131

SERVICE MANUAL

MODEL: PD-121,131

Features of Black light by using a small
Cold Cathode Ultra violet light tube

This small discharge type tube was developed for use in our turntable. As its features far outweighed that of the conventional Orange Neon as strobo-scope timing light.

It differs in operation from the usual fluorescent tube in that it has no starting filaments, but instead has a small electrode near each main cathode at each end of the tube. So discharge is enabled by a high firing voltage (250 volts).

However, since mercury is used as the gaseous medium in the sealed tube operation at very low temperatures eg. below 5°C is very difficult. But with the special firing circuits used in the PD-121, operation is guaranteed from above 0°C.

This tube is characterized by

- 1) Low power consumption (0.7W)
- 2) Low operating temperature
- 3) Small-size
- 4) Long-life (20,000 hours)
- 5) Ultra Violet light at 3650 Å.

So to make the strobo-scope pattern very clear as if to appear stationary, the tube is fired by short duration pulses, and to make for a high visibility "dayglo" type paint is used for the strobo markings, this type of paint converts Ultra violet light into visible coloured light.

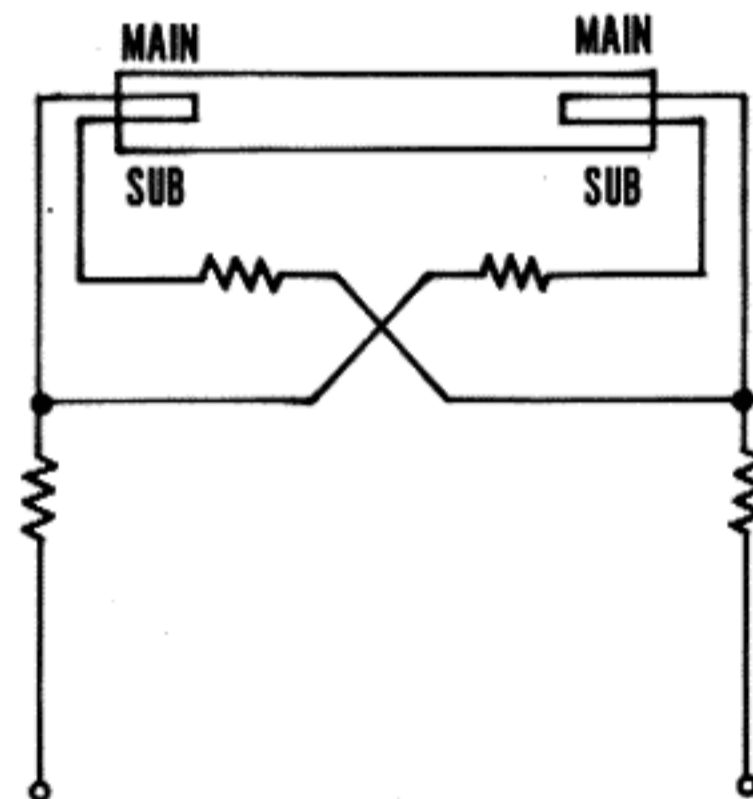

ALIGNMENT PROCEDURE

- 1) PB-650 D.C. voltage adjust

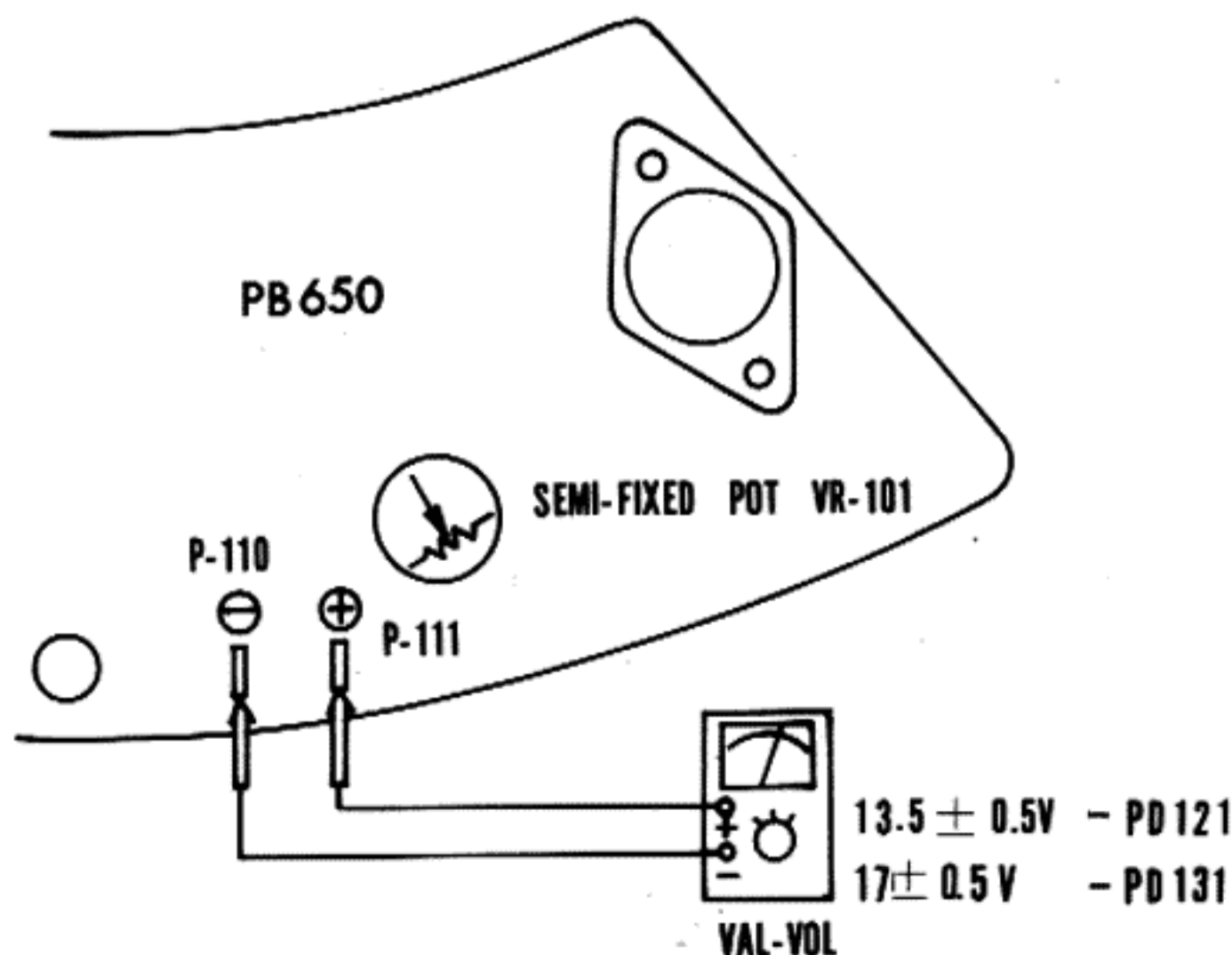

2) Pre-adjust of the Turntable position

- a) After mounted every components on both the chassis and the panel, these two shall be put together.
- b) Loosen the 4 screws for provisional fixing, and put the turntable on.
- c) Provisionally fix the motor when the equivalent gap between the panel and the turntable is obtained as per the drawing. (The provisional fixing is possible with a (+) driver through the 2 holes for tightening of the motor-fixing (-) screw on the turntable.)

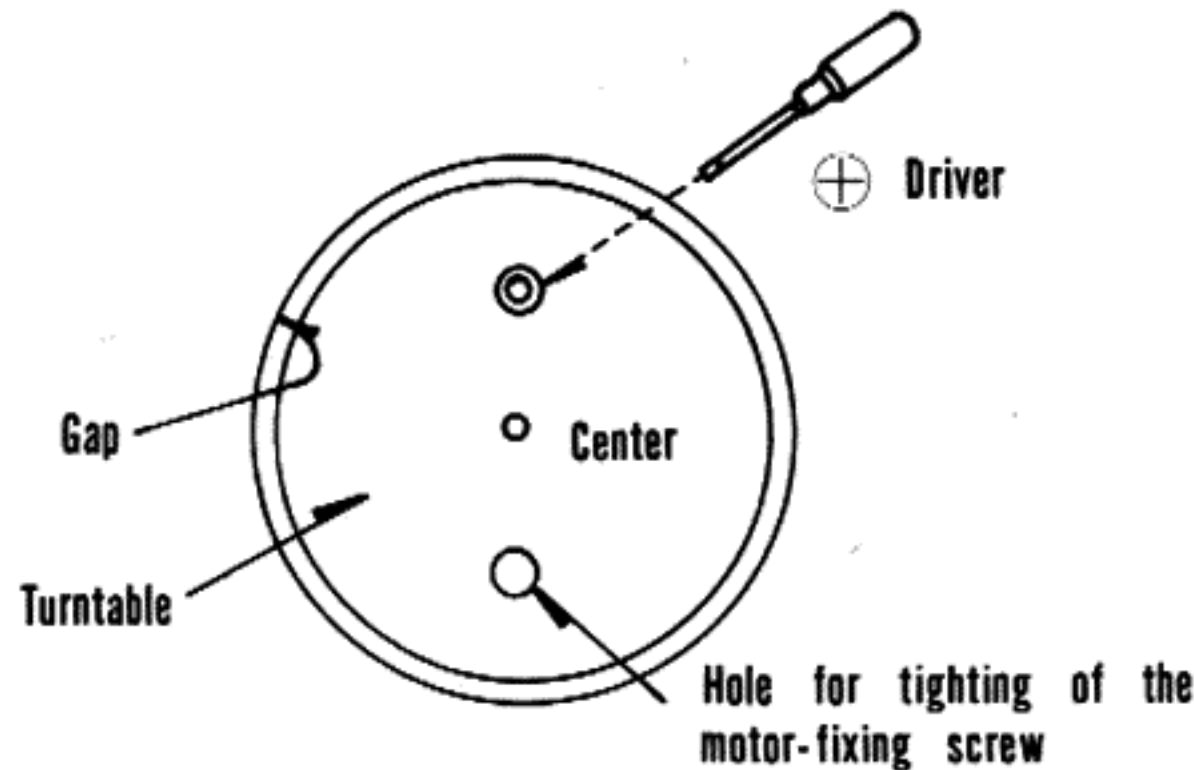

3) Pre-adjust of the Reed Switch and the height of the Selector Switch

- a) Hold the switch-button on the panel with the SCOTCH drafting tape etc, and put together with the chassis. Note that the chassis and the wood-frame should not be screwed together at this stage.
- b) Adjust the screw which fixes the switch-mount metal so that the button protrudes about 2mm from the panel-surface.
- c) Power-on with the mains cord connected to the rated AC mains power source.
- d) Operate the speed selector switch to check through the stroboscope whether smooth speed-selection is possible. (In case correct rotation is realized, the figures in the stroboscope are observed standstill.)
- e) When the above selection is found to be not smooth, re-check its operation by varying the position of the switch-mount metal, which is stated in the (b) clause.
- f) Further, when the operation checked in (e) is found unstable, check again with moving the Reed Switch as per the drawing.

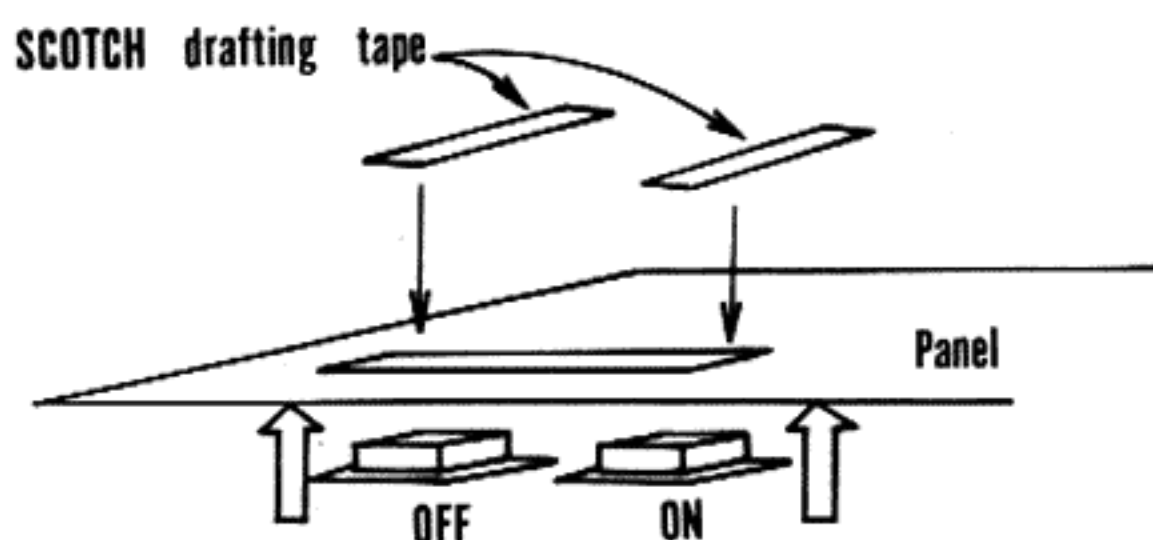
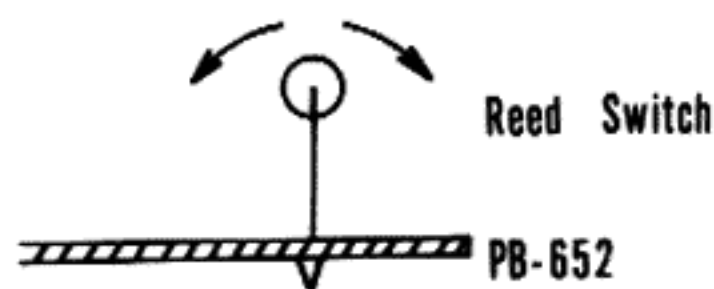

BLOCK DIAGRAM

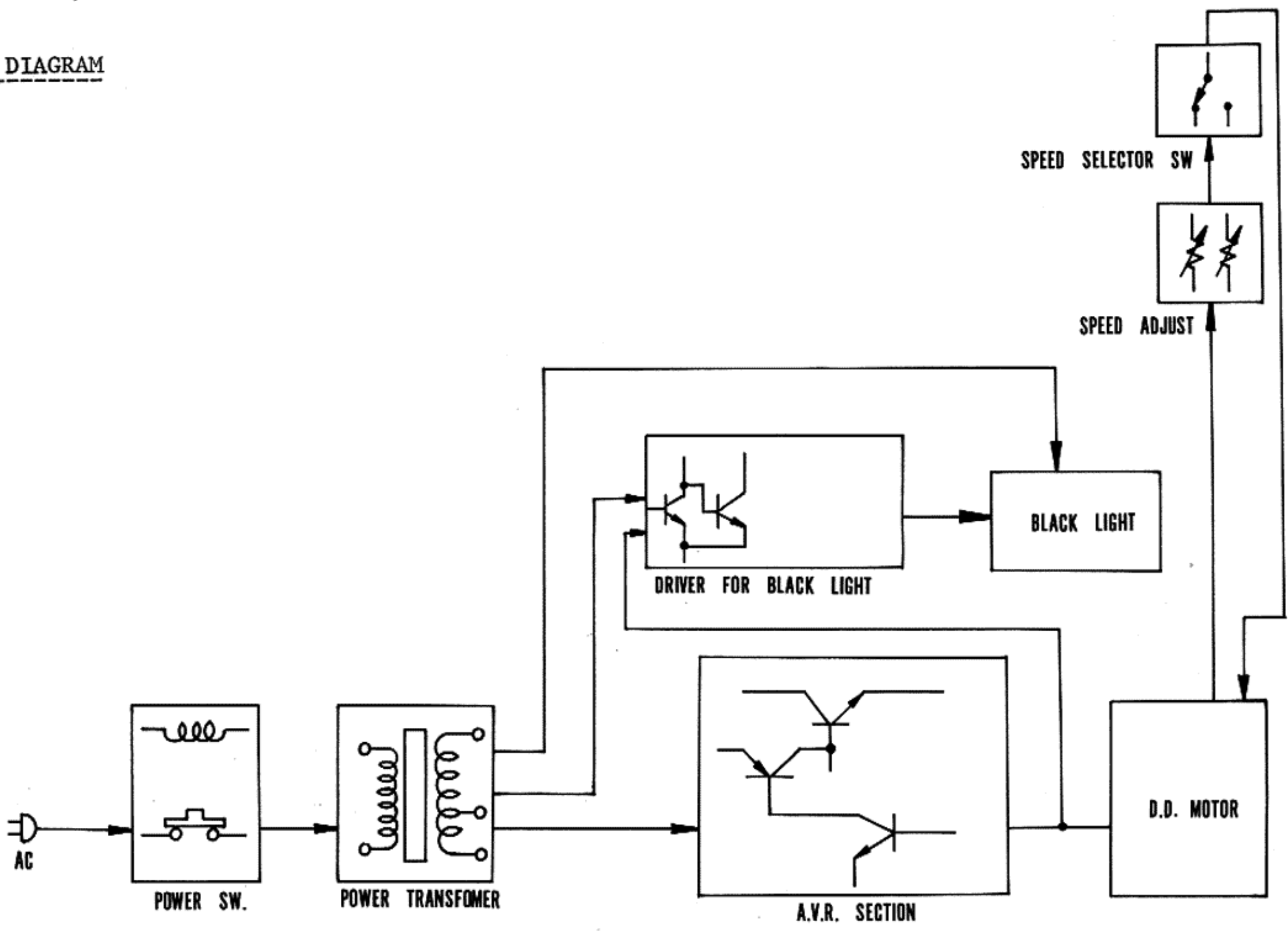

CIRCUIT DIAGRAM FOR BLACK-LIGHT

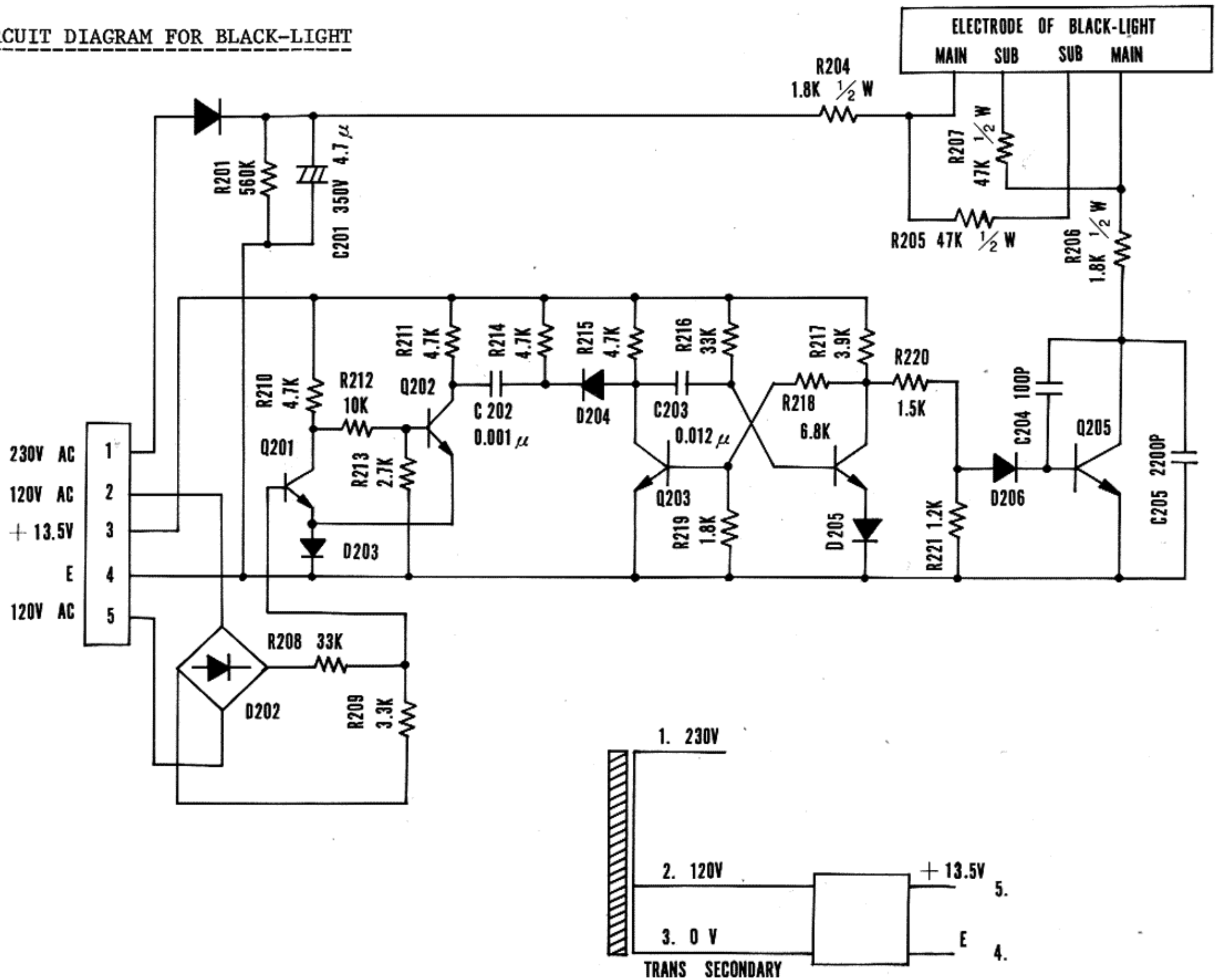

※ NUMBERS ARE EQUIVALENT TO THE SOCKET NUMBERS.

CIRCUIT DIAGRAM

