

# Operating Instructions

# STEREO AMPLIFIER A-88X

Side panels not supplied with Europe and U.K. Models.

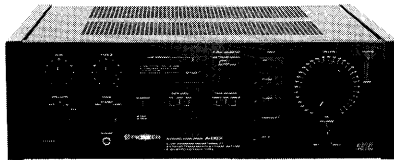

Photograph shows BLACK finished model.

Thank you for buying this Pioneer product. Please read through these operating instructions and then you will know how to operate your model properly. After you have finished reading the instructions, put them away in a safe place for future reference.

In accordance with the power and voltage requirements of differing areas, the following model names are used to designate models with differing electrical specifications.

Models	Line voltage
HE, HEZ, NE, NEZ	a.c. 220 volts ~
WE, WB, WP	a.c. 220-240 volts ~
S, S/G, SS	AC 110, 120, 220, 240 volts (Switchable voltage)
D, D/G	AC 120, 220, 240 volts (Switchable voltage)
R, R/G	AC 110-120, 220-240 volts (Switchable voltage)
KU, KC	AC 120 volts
YP, YB, HB, HP	a.c. 240 volts ~

**NOTES:**

- The model names are stamped on the packing case.
- These operating instructions are prepared on the basis of the KU model, and they can be used for other models. Although the design of the power plug and the power outlet shown may differ from the actual one, the operating procedures are the same.

**WARNING:** TO PREVENT FIRE OR SHOCK HAZARD, DO NOT EXPOSE THIS APPLIANCE TO RAIN OR MOISTURE.

### LINE VOLTAGE SELECTOR SWITCH

Only multi-voltage models are provided with this switch. U.S.A., Canadian, European, U.K., and Australian models are not provided with this switch.

You will find the line voltage selector switch on the rear panel. This switch has positions for 110 V, 120 V, 220 V and 240 V power sources. Before your model is shipped from the factory, the switch is set to the power requirements of the destination; nevertheless, you should check that it is set properly before plugging the power cord into the AC outlet. If the voltage is not properly set or if you move to an area where the voltage requirements differ, adjust the selector switch as follows. Before adjusting disconnect the power cord.

1. Provide yourself with a medium size flat tip screwdriver.
2. Insert the screwdriver into the arrow on the voltage selector and adjust so that the tip of the arrow points to the voltage value of your area.

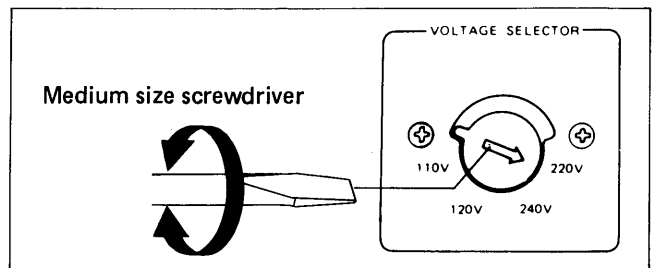

### IMPORTANT NOTICE [For U.S.A. and Canadian models]

The serial number for this equipment is located on the rear panel. Please write this serial number on your enclosed warranty card and keep in a secure area. This is for your security.

## CONTENTS

Connections .....	3	Specifications .....	10
Panel Facilities .....	4	Troubleshooting .....	11
Operations .....	7		

# SAFETY INSTRUCTIONS

**READ INSTRUCTIONS** — All the safety and operating instructions should be read before the appliance is operated.

**RETAIN INSTRUCTIONS** — The operating instructions should be retained for future reference.

**HEED WARNING** — All warnings on the appliance and in the operating instructions should be adhered to.

**FOLLOW INSTRUCTIONS** — All operating and use instructions should be followed.

**WATER AND MOISTURE** — The appliance should not be used near water — for example, near a bathtub, washbowl, kitchen sink, laundry tub, in a wet basement, or near a swimming pool, etc.

**LOCATION** — The appliance should be installed in a stable location.

**WALL OR CEILING MOUNTING** — The appliance should not be mounted to a wall or ceiling.

**VENTILATION** — The appliance should be situated so that its location or position does not interfere with its proper ventilation. For example, the appliance should not be situated on a bed, sofa, rug, or similar surface that may block the ventilation openings; or, placed in a built-in installation, such as a bookcase or cabinet that may impede the flow of air through the ventilation openings.

**HEAT** — The appliance should be situated away from heat sources such as radiators, heat registers, stoves, or other appliances (including amplifiers) that produce heat.

**POWER SOURCES** — The appliance should be connected to a power supply only of the type described in the operating instructions or as marked on the appliance.

**POWER-CORD PROTECTION** — Power-supply cords should be routed so that they are not likely to be walked on or pinched by items placed upon or against them, paying particular attention to cords at plugs, convenience receptacles, and the point where they exit from the appliance.

**POLARIZATION** — If your purchased product is provided with a polarized power plug, please read the following instructions. This product is equipped with a polarized alternating current line plug (a plug having one blade wider than the other). This plug will fit into the power outlet only one way. This is a safety feature. If you are unable to insert the plug fully into the outlet, try reversing the plug. If the plug should still fail to fit, contact your electrician to replace your obsolete outlet. Do not defeat the safety purpose of the polarized plug.

**CLEANING** — The appliance should be cleaned only with a polishing cloth or a soft dry cloth. Never clean with furniture wax, benzene, insecticides or other volatile liquids since they may corrode the cabinet.

**POWER LINES** — An outdoor antenna should be located away from power lines.

**NONUSE PERIODS** — The power cord of the appliance should be unplugged from the outlet when left unused for a long period of time.

**OBJECT AND LIQUID ENTRY** — Care should be taken so that objects do not fall and liquids are not spilled into the enclosure through openings.

**DAMAGE REQUIRING SERVICE** — The appliance should be serviced by Pioneer authorized service center or qualified service personnel when:

- The power-supply cord or the plug has been damaged; or
- Objects have fallen, or liquid has been spilled into the appliance; or
- The appliance has been exposed to rain; or
- The appliance does not appear to operate normally or exhibits a marked change in performance; or
- The appliance has been dropped; or the enclosure damaged.

**SERVICING** — The user should not attempt to service the appliance beyond that described in the operating instructions. For all other servicing, contact the nearest Pioneer authorized service center.

**OUTDOOR ANTENNA GROUNDING** — If an outside antenna is connected to the antenna terminal, be sure the antenna system is grounded so as to provide some protection against voltage surges and built up static charges.

In the U.S.A. section 810 of the National Electrical Code, ANSI/NEPA No. 70-1984, provides information with respect to proper grounding of the mast and supporting structure, grounding of the lead-in wire to an antenna discharge unit, size of grounding conductors, location of antenna-discharge unit, connection to grounding electrodes, and requirements for the grounding electrode. See Fig. A.

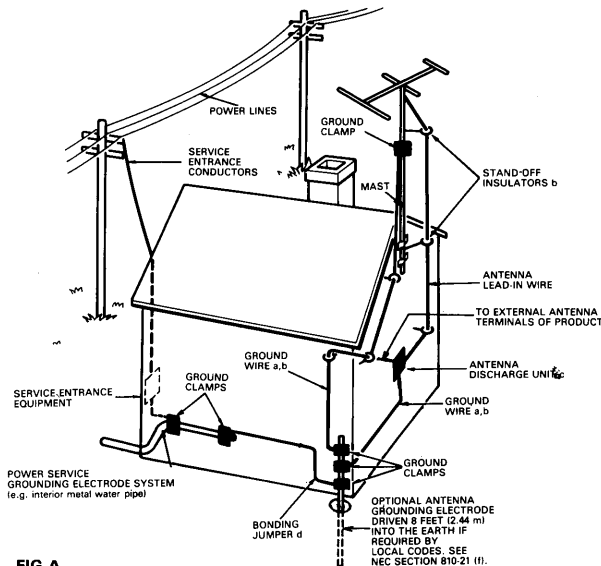

- Use No. 10 AWG (5.3 mm<sup>2</sup>) copper, No. 8 AWG (8.4 mm<sup>2</sup>) aluminum, No. 17 AWG (1.0 mm<sup>2</sup>) copper-clad steel, bronze wire, or larger as ground wire.
- Secure antenna lead-in and ground wires to house with stand-off insulators spaced from 4 feet (1.22 meters) to 6 feet (1.83 meters) apart.
- Mount antenna discharge unit as closely as possible to where lead-in enters house.
- Use jumper wire not smaller than No. 6 AWG (13.3 mm<sup>2</sup>) copper or equivalent when separate antenna-grounding electrode is used.

## IMPORTANT 1



The lightning flash with arrowhead, within an equilateral triangle, is intended to alert the user of the presence of uninsulated "dangerous voltage" within the product's enclosure that may be of sufficient magnitude to constitute a risk of electric shock to persons.

### CAUTION

RISK OF ELECTRIC SHOCK  
DO NOT OPEN

**CAUTION:**  
**TO PREVENT THE RISK OF ELECTRIC SHOCK, DO NOT REMOVE COVER (OR BACK). NO USER-SERVICEABLE PARTS INSIDE. REFER SERVICING TO QUALIFIED SERVICE PERSONNEL.**



The exclamation point within an equilateral triangle is intended to alert the user of the presence of important operating and maintenance (servicing) instructions in the literature accompanying the appliance.

## IMPORTANT 2

If the apparatus is fitted with AC mains power outlet(s), see REAR PANEL FACILITIES for convenient connection of additional Hi-Fi component(s). Make all connections to the AC outlet(s) and the signal terminals first. Connect the plug to the wall socket last, make sure that the power switch is off. Disconnect the wall plug when the equipment is not in (regular) use, e.g. when on vacation.

## FOR USE IN THE UNITED KINGDOM

The wires in this mains lead are coloured in accordance with the following code:

Blue:	Neutral
Brown:	Live

As the colours of the wires in the mains lead of this apparatus may not correspond with the coloured marking identifying the terminals in your plug proceed as follows:

The wire which is coloured blue must be connected to the terminal which is marked with the letter N or coloured black.

The wire which is coloured brown must be connected to the terminal which is marked with the letter L or coloured red.

Equipment sold in the U.K. is not supplied with a power plug.

# CONNECTIONS

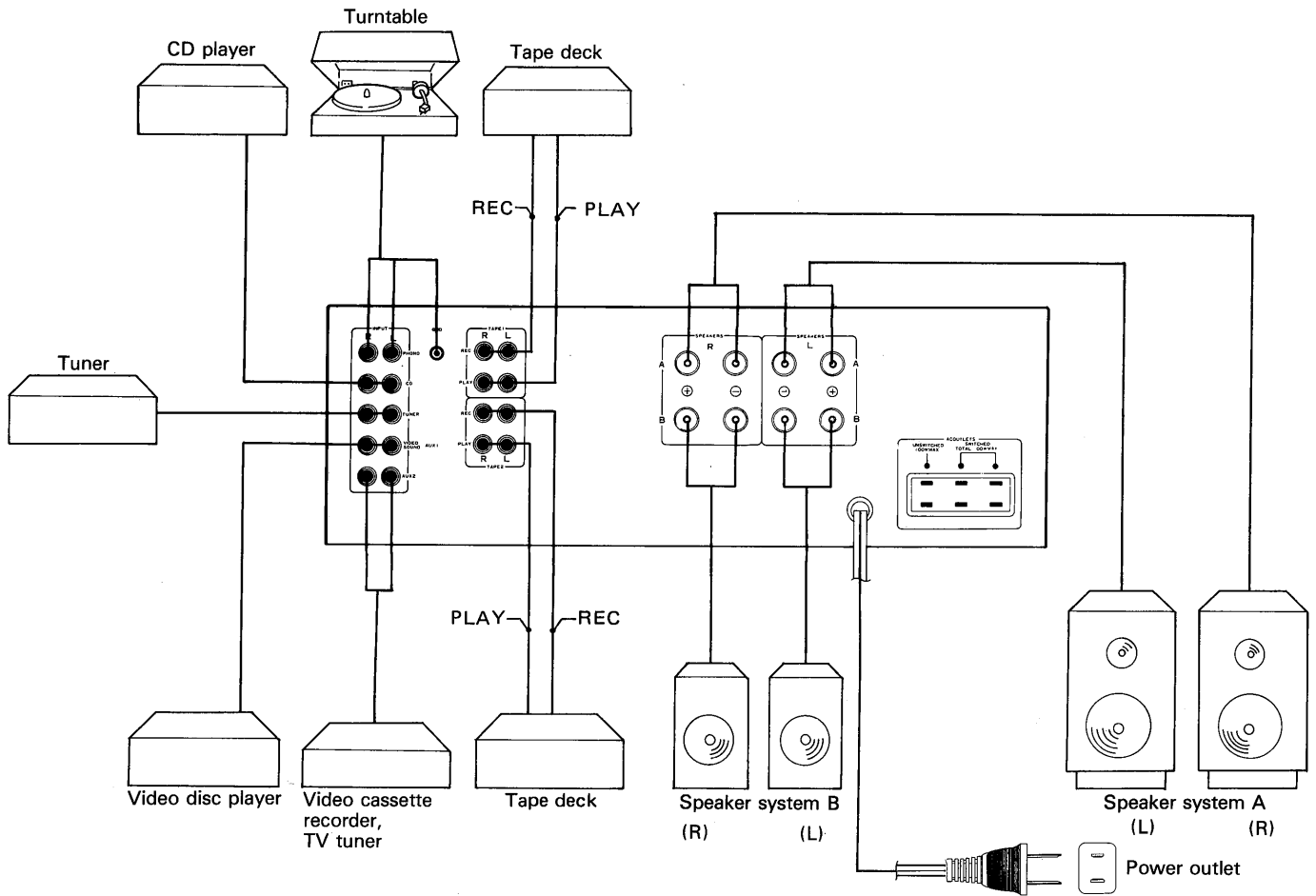

Illustration not applicable to U.K. model

## CONNECTING SPEAKER WIRES

Because this unit produces high output levels, speakers should be connected following the procedure below.

1. Strip off the vinyl covering and twist the tip of the wire.
2. Loosen the knob, and insert the wire into the terminal hole.
3. Tighten the knob to fix the wire in place.

### NOTE:

Do not allow the wire core to protrude and touch other terminals or wires. If the cores of differing wires touch, damage may be caused to your components.

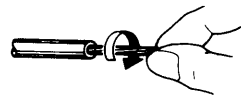

Twist the wire core

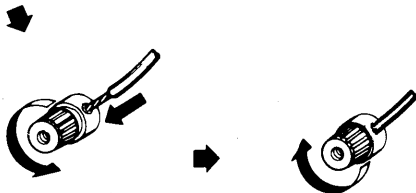

## CONNECTING INPUT/OUTPUT CORDS

Connect the white plug to the L (left) side, and the red plug to the R (right) side. Be sure to push the plugs in securely.

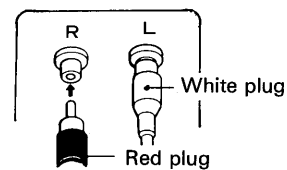

## CONNECTING THE POWER CORD (For U.S.A. and Canadian models)

Household electrical outlets are provided with specific polarity, a positive side and a negative (ground) side. This unit utilizes such polarity in order to improve sound quality. As shown in the illustration, be sure to insert the power plug so that its blades match the width of slots in the outlet.

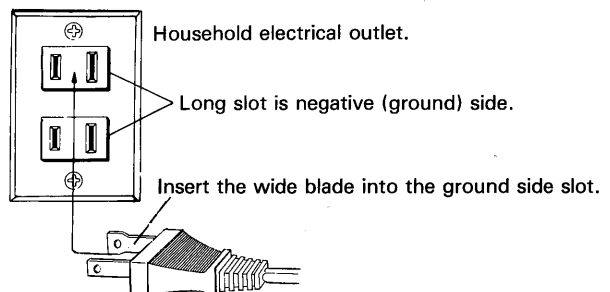

# PANEL FACILITIES

## REAR PANEL

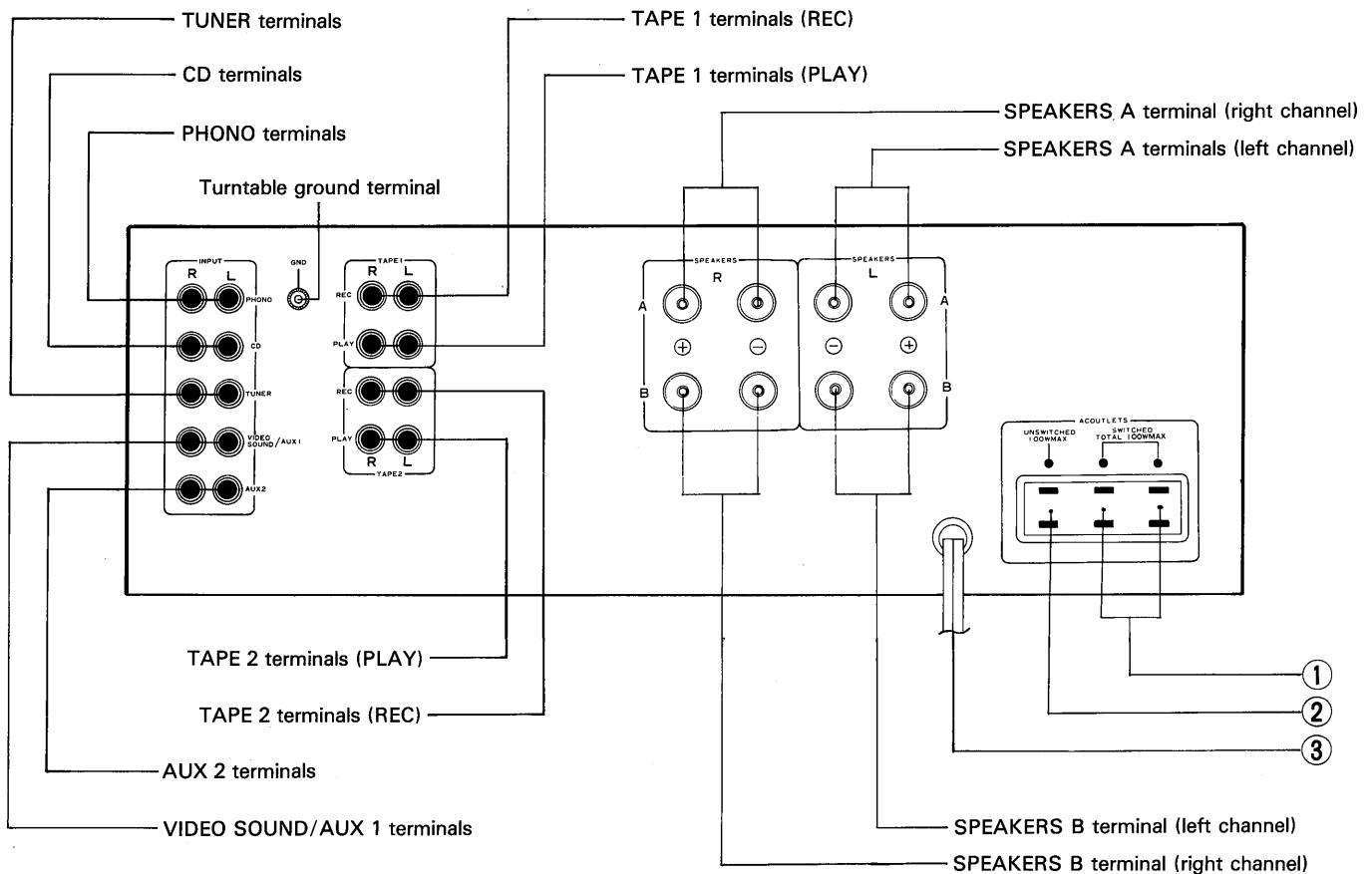

### ① AC OUTLETS (SWITCHED)

Power supplied through these outlets is turned on and off by the amplifier's POWER switch. Total electrical power consumption of connected equipment should not exceed 100 W. (80W on Europe, U.K. Australia models).

### ② AC OUTLET (UNSWITCHED)

Power flows continually to this outlet, regardless of whether the amplifier is switched ON or OFF. Electrical power consumption of the connected equipment should not exceed 100 W. (40W on Europe, U.K. Australia models). The equipment should be disconnected by removing the mains plug from the wall socket when not in regular use, e.g. when on vacation.

#### NOTE:

Do not connect appliances with high power consumption such as heaters, irons, or television sets to the AC OUTLETS in order to avoid overheating or fire risk. This can cause the amplifier to malfunction.

### ③ Power cord

Connect this cord to a wall outlet, or the power outlet of an audio timer.

### About the electrical outlets' polarity marking

The auxiliary power outlets on this unit are provided with a polarity marking. When connecting stereo components with polarity-specific plugs to these outlets, be sure to connect the power plugs with the polarity correctly aligned, since this will result in better sound. The outlet side marked with a black spot (●) corresponds to the negative (ground) side.

### About Speaker Impedance [For European, U.K. and Australian models]

When speaker systems are connected to only one of the SPEAKERS A, B terminals, such speakers should have rated impedance in the range of 6–16 ohms. When speakers are connected to both the A and B terminals, they should have a rated impedance in the range of 12–32 ohms.

### [For other models]

When speaker systems are connected to only one of the SPEAKERS A, B terminals, such speakers should have rated impedance in the range of 4–16 ohms. When speakers are connected to both the A and B terminals, they should have a rated impedance in the range of 8–32 ohms.

FRONT PANEL

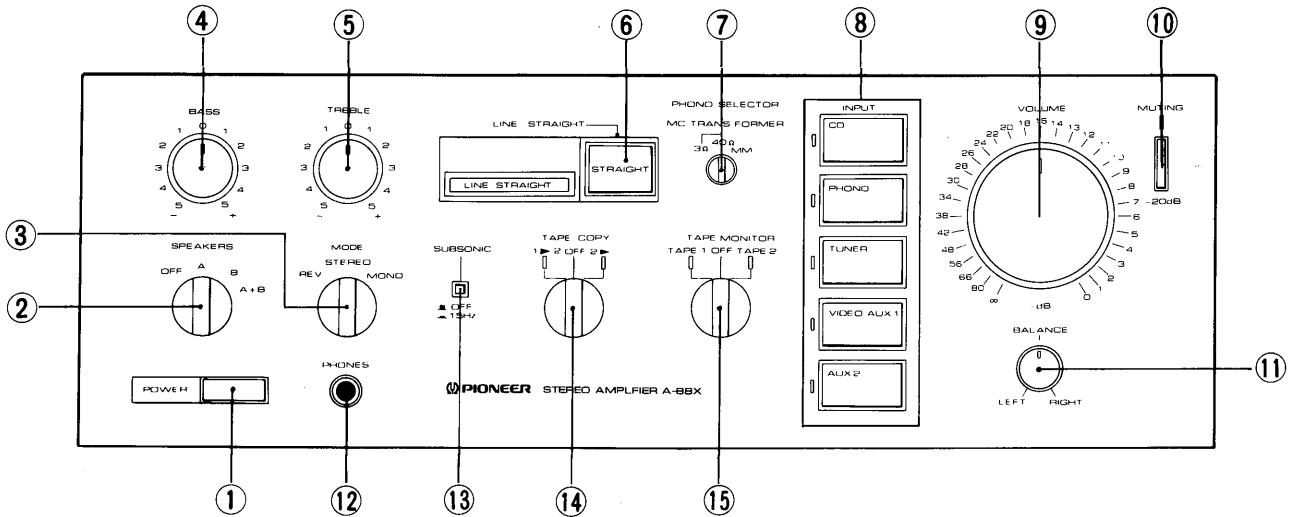

① POWER switch/indicator

Press to turn power to the unit ON and OFF.  
 Depressed position (ON): Power is supplied to the unit.  
 Released position (OFF): Power to the unit is disconnected.

② SPEAKERS selector switch

Use to select the speaker systems used for playback.

[OFF]  
 — No sound is produced from the speaker systems. Set to this position when using headphones.

[A]  
 — Sound is produced from the speaker systems connected to the SPEAKERS A terminals.

[B]  
 — Sound is produced from the speaker systems connected to the SPEAKERS B terminals.

[A + B]  
 — Sound is produced from both the speaker systems connected to the SPEAKERS A and SPEAKERS B terminals.

③ MODE selector switch

Use to select the playback mode.

[STEREO]  
 — Set here for normal stereo reproduction.  
 The left-channel sound (signals connected to the rear panel L terminals) will be produced from the left-side speaker systems, and right-channel sound (signals connected to the rear panel R terminals) will be produced from the right-side speaker systems.

[REV]  
 — When set to this position, the stereo channels will be reversed, the left-channel sound being produced from the right side speaker systems, and the right-channel sound being produced from the left-side speaker systems.

[MONO]  
 — The left-channel and right-channel signals will be mixed and produced from the right and left side speaker systems simultaneously.  
 This function does not operate when the LINE STRAIGHT switch is in the ON position.

④ BASS tone control

Use to adjust the low-frequency tones. The central "0" position is the flat (normal) position. When turned to the right, low-frequency tones are emphasized; when turned to the left, low-frequency tones are de-emphasized.  
 This function does not operate when the LINE STRAIGHT switch is in the ON position.

⑤ TREBLE tone control

Use for adjusting the high-frequency tones. The central "0" position is the flat (normal) position. When turned to the right, high-frequency tones are emphasized; when turned to the left, high-frequency tones are de-emphasized.  
 This function does not operate when the LINE STRAIGHT switch is in the ON position.

⑥ LINE STRAIGHT switch/indicator

By using this switch, the input signals from the various connected peripheral components can be played back through the amplifier's modifying (tone, mode) circuits, or bypassing those circuits.  
 When the indicator is lighted, the function is ON. Input signals will bypass the modifying circuits and be played back with pure, flat-balanced tone.  
 When set to OFF, input signals will pass through the modifying circuits before being played back, thus allowing you to adjust bass and treble tone, and select the mode of playback with the MODE selector switch.

⑦ PHONO SELECTOR switch

Set in accordance with the type of cartridge used in your turntable.

[MC TRANSFORMER]  
 — When using an MC (moving coil) cartridge, set either to the [3 Ω] or [40 Ω] position. The 3 ohm and 40 ohm selection should be made on the basis of the cartridge's load resistance (impedance) value.

## PANEL FACILITIES

### [MM]

- Set to this position when using an MM (moving magnet) cartridge, or an MC (moving coil) cartridge with high output of 1 mV or more.

### ⑧ FUNCTION switches/indicators

#### [CD]

- Press when listening to a compact disc playback with a CD player.

#### [PHONO]

- Press when listening to record playback on a turntable.

#### [TUNER]

- Press when listening to AM or FM broadcasts with a tuner.

#### [VIDEO/AUX 1]

- Press when listening to programs from a component connected to the VIDEO SOUND/AUX 1 terminals.

#### [AUX 2]

- Press when listening to programs from a component connected to the AUX 2 terminals.

### ⑨ VOLUME control

These are used for controlling the sound volume.

When set to the [∞] position, sound volume is turned off; when set to the [0] position, sound volume is at a maximum.

### ⑩ MUTING switch/indicator

Use to temporarily cut sound volume.

When pressed ON, indicator will light, and sound volume will be cut by 20 dB. When set to OFF, the sound will return to its previous volume.

### ⑪ BALANCE control

Should normally be left in the center position. Adjust balance if the sound is louder from one of the speakers. If the right side is louder, turn toward the (L) position and if the left side is louder, turn toward the (R) position.

### ⑫ PHONES jack

When using headphones, insert their plug into this jack.

### ⑬ SUBSONIC filter switch

Use this switch when playing records with coarse grooves.

#### [OFF]

- Released position; leave in this position for normal playback.

#### [15Hz]

- Depressed position; in this position, frequencies of 15Hz and below are cut, thus eliminating super-low-frequency noise caused by coarse record grooves, and thus helping prevent sound distortion.

### ⑭ TAPE COPY switch/indicator

Use when performing tape copying between two tape decks connected to the amplifier.

#### [1 ► 2]

- Set in this position when performing tape copying from the tape deck connected to the TAPE 1 PLAY terminals to the deck connected to the TAPE 2 REC terminals.

#### [OFF]

- Leave set in this position when not performing tape copying.

#### [2 ► 1]

- Set in this position when performing tape copying from the tape deck connected to the TAPE 2 PLAY terminals to the deck connected to the TAPE 1 REC terminals.

### ⑮ TAPE MONITOR switch/indicator

Use this switch to listen to tape playback, or to listen to the sounds being recorded during tape recording.

#### [TAPE 1]

- Set to this position to listen to the playback sound of the tape deck connected to the TAPE 1 PLAY terminals, or to monitor the sound being recorded on the tape deck connected to the TAPE 1 REC terminals.

#### [OFF]

- Leave set in this position when not listening to tape playback.

#### [TAPE 2]

- Set to this position to listen to the playback sound of the tape deck connected to the TAPE 2 PLAY terminals, or to monitor the sound being recorded on the tape deck connected to the TAPE 2 REC terminals.

## Accessories

(Side panels not supplied with Europe and U.K. models)

Wood-grain side panel x 2

Side panel mount screw x 4

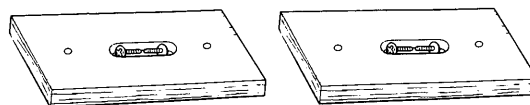

# OPERATIONS

## BEFORE BEGINNING OPERATIONS

Set the controls and switches as follows:

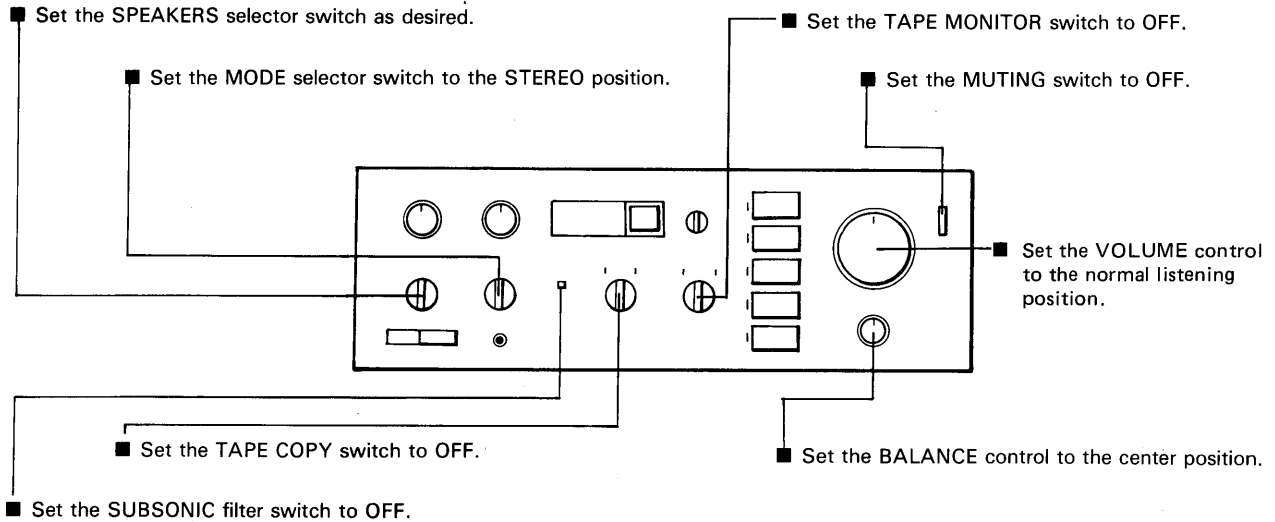

## TO LISTEN TO FM/AM BROADCASTS:

- (1) Set the amplifier and tuner POWER switches to ON.
- (2) Press the FUNCTION switch TUNER.
- (3) Operate the tuner to select a broadcast station.
- (4) Adjust the volume with the unit's VOLUME control.

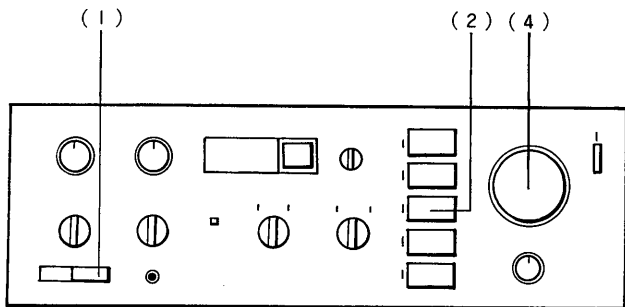

## TO LISTEN TO RECORDS:

- (1) Set the amplifier and turntable POWER switches to ON.
- (2) Press the FUNCTION switch PHONO.
- (3) Set the PHONO SELECTOR switch to match the type of cartridge used on your turntable.
- (4) Operate the turntable to begin record playback.
- (5) Adjust the volume with the unit's VOLUME control.

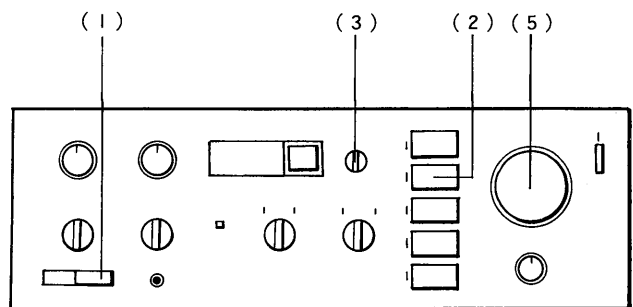

### NOTE:

When playing back records with coarse grooves, super-low-frequency noise may cause cross-modulation distortion, resulting in distorted sound and possible damage to speakers. In this event, setting the SUBSONIC filter switch to [ON] will allow you to eliminate super-low-frequency noise (15 Hz and below).

## OPERATIONS

### TO LISTEN TO TAPES:

- (1) Set the amplifier and tape deck **POWER** switches to **ON**.
- (2) Set the **TAPE MONITOR** switch as desired.
  - To listen to the tape deck connected to TAPE 1 PLAY terminals: — Set to [TAPE 1].
  - To listen to the tape deck connected to TAPE 2 PLAY terminals: — Set to [TAPE 2].
- (3) Operate the tape deck to begin tape playback.
- (4) Adjust the volume with the unit's **VOLUME** control.

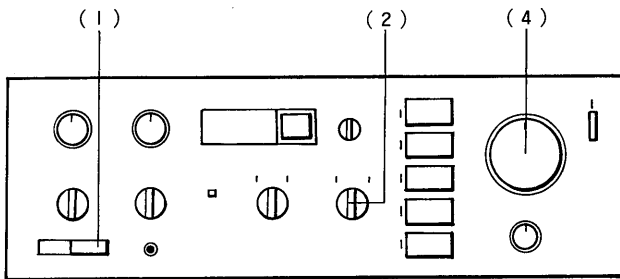

### RECORDING TAPES:

- While listening to AM/FM broadcasts, records, compact discs, or the component connected to the VIDEO SOUND/AUX 1 and AUX 2 terminals, you can record these same sounds on tape merely by setting your tape deck to the recording mode.
- Refer to the operating instructions for your tape deck for proper operating procedures.

#### NOTE:

When performing normal recording, be sure to set the **TAPE COPY** switch to the [OFF] position. Normal recording is not possible when the switch is set to any other position.

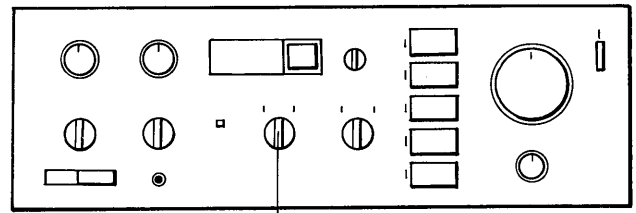

TAPE COPY switch [OFF]

### TO LISTEN TO THE COMPONENT CONNECTED TO THE CD, VIDEO SOUND/AUX 1 and AUX 2 TERMINALS:

- (1) Set the **POWER** switches of the amplifier and component to be used to **ON**.
- (2) Set the **FUNCTION** switches as desired.
  - To listen to a compact disc player: — Press [CD].
  - To listen to a component connected to the VIDEO SOUND/AUX 1 terminals: — Press [VIDEO/AUX 1].
  - To listen to a component connected to the AUX 2 terminals: — Press [AUX 2].
- (3) Operate the component to begin playback.
- (4) Adjust the volume with the unit's **VOLUME** control.

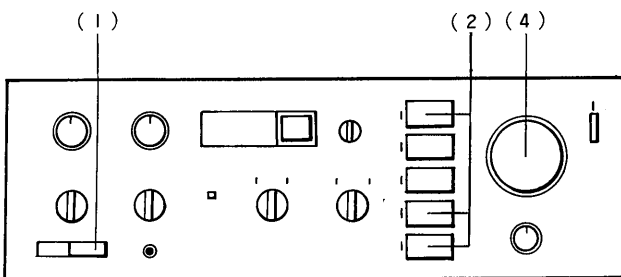

### MONITORING SOUND DURING RECORDING

When a three-head tape deck is used for recording, the sound actually being recorded can be listened to to check the tone and recording levels. This is called "monitoring" the sound. When monitoring a recording, set the tape monitor switch to match the tape deck being used to perform the recording.

- When recording on the tape deck connected to the TAPE 1 REC terminals: — Set to [TAPE 1].
- When recording on the tape deck connected to the TAPE 2 REC terminals: — Set to [TAPE 2].

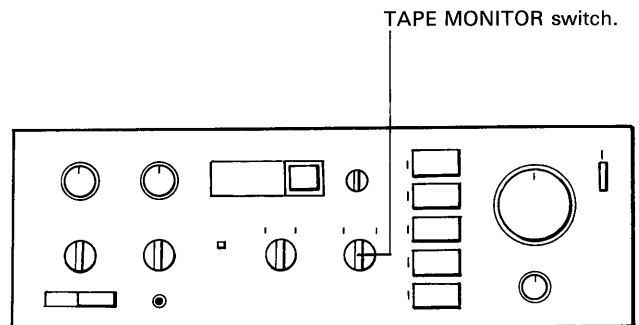

TAPE MONITOR switch.



**COPYING TAPES:**

When two tape decks (or a double cassette deck) are used, you can record the sounds from one deck onto the other.

Application examples:

- To make a tape copy with identical contents to the original tape.
- To edit a recording of an FM broadcast in order to cut out unwanted commercials, recording only desired material onto another tape.

**[When using two tape decks]**

**(1) Load tapes for playback (pre-recorded tape) and recording (non-recorded tape) into the respective tape decks.**

**(2) Select the proper TAPE COPY switch.**

- When copying from the deck connected to the TAPE 1 PLAY terminals to the deck connected to the TAPE 2 REC terminals: — Set to [1 ► 2].
- When copying from the deck connected to the TAPE 2 PLAY terminals to the deck connected to the TAPE 1 REC terminals: — Set to [2 ► 1].

**(3) Set the TAPE MONITOR switch as desired.**

- To listen to the sound being played back: — Set to the position corresponding to the tape deck used for playback ([TAPE 1] or [TAPE 2]).
- To monitor the sound being recorded (only possible when recording with a 3-head tape deck): — Set to the position corresponding to the tape deck used for recording ([TAPE 1], or [TAPE 2]).
- To listen to a sound source other than tape during recording: — Set to [OFF], and set the FUNCTION switch as appropriate.

**(4) Operate the tape decks to begin copying.**

Set the tape deck with the original (playback) tape to the playback mode, and set the tape deck with the non-recorded tape to the recording mode.

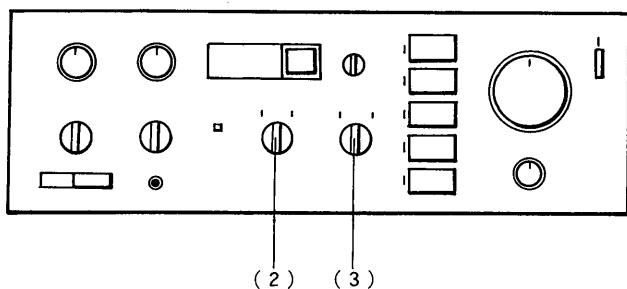

# SPECIFICATIONS

## Amplifier Section

Continuous average power output is 120 watts\* per channel, min., at 8 ohms from 20 Hertz to 20,000 Hertz with no more than 0.003% total harmonic distortion.

DIN, Continuous Power Output (both channels driven)  
T.H.D. 1%, 1 kHz, 8Ω ..... 150 W per channel  
Dynamic Power (EIA), 8Ω, 4Ω, 2Ω  
..... 169 W/300 W/441 W

Total Harmonic Distortion  
(20 Hz to 20 kHz, 8 Ω, from CD)  
120 W per channel power output  
..... No more than 0.003%

Cross-harmonic distortion (50 Hz : 7 kHz = 4 : 1)  
At effective output ..... 0.003%

Output bandwidth (both channels driven)  
..... 5 Hz — 60 kHz (distortion 0.01%, 8 Ω)

Damping Factor (20 Hz to 20 kHz, 8 Ω) ..... 100

Input (Sensitivity/Impedance)  
PHONO MM ..... 2.5 mV/50 kΩ  
PHONO MC ..... 0.25 mV/40 Ω,  
0.15 mV/3 Ω MC transformer  
TUNER, CD, AUX 1, 2, TAPE PLAY 1, 2  
..... 150 mV/30 kΩ

Phono Overload Level  
PHONO MM (T.H.D. 0.003%, 1 kHz) ..... 250 mV  
PHONO MC (T.H.D. 0.003%, 1 kHz)  
Input sensitivity 0.25 mV 40 Ω ..... 22 mV  
Input sensitivity 0.15 mV 3 Ω ..... 13 mV

Cartridge load capacity/load impedance  
PHONO MM ..... 220 pF/50 kΩ

Output (Level/Impedance)  
TAPE REC 1, 2 ..... 150 mV/2.2 kΩ

Frequency Response  
PHONO (RIAA Equalization) MM, MC  
..... 20 Hz to 20 kHz ±0.2 dB  
TUNER, CD, AUX 1, 2, TAPE PLAY 1, 2  
..... 10 Hz — 100 kHz ±0.5 dB

Tone Control  
BASS ..... ±8 dB (100 Hz)  
TREBLE ..... ±8 dB (10 kHz)

SUBSONIC filter ..... 15 Hz (-6 dB/oct)  
Muting ..... -20 dB

Hum and Noise (short circuited, A network)  
PHONO MM ..... 89 dB  
PHONO MC ..... 76 dB (3/40 Ω)  
CD, AUX 1, 2, TUNER,  
TAPE PLAY 1, 2 ..... 110 dB

Hum and Noise (DIN, continuous power /50 mW)  
PHONO MM ..... 74 dB/61 dB  
CD, AUX 1, 2, TUNER,  
TAPE PLAY 1, 2 ..... 91 dB/63 dB

Channel Separation (10 kHz)  
PHONO MM/MC ..... 65 dB/62 dB  
CD, TUNER, AUX 1, 2, TAPE PLAY 1, 2 ..... 72 dB  
(Line Straight Switch ON)

Channel Separation (1 kHz)

PHONO MM/MC ..... 75 dB/70 dB  
CD, TUNER, AUX 1, 2, TAPE PLAY 1, 2 ..... 90 dB  
(Line Straight Switch ON)

## Miscellaneous

### Power Requirements

HE model ..... a.c. 220 V ~, 50/60 Hz  
HB, YP models ..... a.c. 240 V ~, 50/60 Hz  
S, S/G models ..... ~AC 110 V/120 V/220 V/240 V  
(switchable), 50/60 Hz  
KU, KC models ..... AC 120 V, 60 Hz

### Power Consumption

HE model ..... 1000 W  
HB, YP models ..... 1000 W  
S, S/G models ..... 670 W  
KU model ..... 670 W (UL)  
KC model ..... 820 VA (CSA)

### Dimensions

HE, HB models ..... 420(W) x 154(H) x 427(D) mm  
16-1/2(W) x 6-1/8(H) x 16-3/4(D) in  
YP, S, S/G, KU, KC models  
..... 457(W) x 155(H) x 427(D) mm  
18(W) x 6-1/8(H) x 16-3/4(D) in

### Weight (without package)

HE, HB models ..... 16.5 kg (36 lb 6 oz)  
YP, S, S/G, KU, KC models ..... 18 kg (39 lb 11 oz)

## Furnished Parts

Operating Instructions ..... 1  
Side Panel (YP, S, S/G, KU, KC models only) ..... 2  
Side Panel mount screw  
(YP, S, S/G, KU, KC models only) ..... 4

### NOTE:

- Specifications and design subject to possible modification without notice due to improvements.
- \*Measured pursuant to the Federal Trade Commission's Trade Regulation rule on Power Claims for Amplifiers.

[For Canadian model]

**CAUTION:** TO PREVENT ELECTRIC SHOCK DO NOT USE THIS (POLARIZED) PLUG WITH AN EXTENSION CORD, RECEPTACLE OR OTHER OUTLET UNLESS THE BLADES CAN BE FULLY INSERTED TO PREVENT BLADE EXPOSURE.

**ATTENTION:** POUR PREVENIR LES CHOCS ELECTRIQUES NE PAS UTILISER CETTE FICHE POLARISEE AVEC UN PROLONGATEUR, UNE PRISE DE COURANT OU UNE AUTRE SORTIE DE COURANT, SAUF SI LES LAMES PEUVENT ETRE INSEREES A FOND SANS EN LAISSER AUCUNE PARTIE A DECOUVERT.

# TROUBLESHOOTING

Incorrect operations are often mistaken for trouble and malfunctions. If you think that there is something wrong with this component, check out the points below. Sometimes the trouble may lie in another component. Investigate the other components and electrical appliances being used.

If the trouble cannot be rectified even after exercising the checks listed below, ask your nearest PIONEER authorized service center or your dealer to carry out repair work.

Symptom	Probable Cause	Remedy
<b>No power supplied to unit.</b>	<ul style="list-style-type: none"> <li>• Power plug is disconnected from outlet.</li> <li>• The component's power plug has been plugged into another component's power outlet (e.g. timer, etc.), but power to that unit is disconnected.</li> </ul>	<ul style="list-style-type: none"> <li>• Insert plug securely in outlet.</li> <li>• Turn on power to other component.</li> </ul>
<b>No sound.</b>  <b>[During tape playback]</b>  <b>[In other cases]</b>	<ul style="list-style-type: none"> <li>• Connecting cords are disconnected from terminals, or connected incorrectly.</li> <li>• Terminals or connecting cords' pin plugs are dirty.</li> <li>• The SPEAKERS selector switch is set to the OFF.</li> <li>• The TAPE COPY switch is not set to the OFF position (except when performing tape copying).</li> <li>• TAPE MONITOR switch is set to OFF.</li> <li>• Mistaken tape operation</li> <li>• The FUNCTION switch selected does not match the component being played back.</li> <li>• Operation of other components is mistaken.</li> </ul>	<ul style="list-style-type: none"> <li>• Connect securely.</li> <li>• Clean terminals and plugs.</li> <li>• Set switch to ON (A or B)</li> <li>• Set switch to OFF.</li> <li>• Set switch to ON (TAPE 1 or TAPE 2).</li> <li>• Consult the operating instructions for your tape deck.</li> <li>• Set switches correctly (PHONO, TUNER, CD, VIDEO SOUND/AUX 1, AUX 2).</li> <li>• Consult the operating instructions for the other components.</li> </ul>
<b>No sound from one speaker.</b>	<ul style="list-style-type: none"> <li>• Connecting cords or speaker wires are disconnected to that side.</li> <li>• BALANCE control have been adjusted to one side.</li> </ul>	<ul style="list-style-type: none"> <li>• Connect securely.</li> <li>• Adjust BALANCE control to center position.</li> </ul>
<b>Can't record tapes.</b>	<ul style="list-style-type: none"> <li>• The TAPE COPY switch is not set to the OFF position.</li> <li>• Operation of tape deck is mistaken.</li> </ul>	<ul style="list-style-type: none"> <li>• Set switch to OFF.</li> <li>• Consult the operating instructions for the tape deck.</li> </ul>
<b>Can't perform tape copying.</b>	<ul style="list-style-type: none"> <li>• The TAPE COPY switch is set to OFF.</li> <li>• Operation of tape decks is mistaken.</li> </ul>	<ul style="list-style-type: none"> <li>• Set switches correctly (1 ► 2 or 2 ► 1).</li> <li>• Consult the operating instructions for the tape decks.</li> </ul>

## About the accessory wood-grain side panels

(Side panels not supplied with Europe and U.K. models)

When the side panels are used, please abide by the following items:

- Use only the screws accompanying the side panels for installation.
- Do not remove any screws attached to this unit.
- When repacking this unit (for storage or shipment), remove the side panels first.

### Installation:

- (1) Use your fingernail, etc., to remove the two plastic rivets (one on each side) on the sides of the unit. The rivets are made of the pair (A) and (B); be sure to remove both (A) and (B) together.
- (2) Using the holes from which the plastic rivets were removed, attach the wood-grain side panels to the unit with the accessory screws. Be sure to install the panels so that the wood-grain pattern is on the outside.

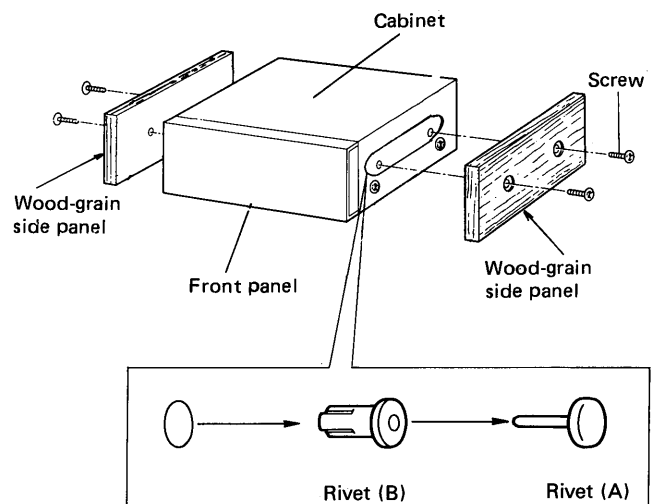

---

**PIONEER ELECTRONIC CORPORATION** 4-1, Meguro 1-Chome, Meguro-ku, Tokyo 153, Japan  
**PIONEER ELECTRONICS (USA) INC.** P.O. Box 1760, Long Beach, California 90801 U.S.A.  
TEL: (800) 421-1404, (800) 237-0424  
**PIONEER ELECTRONIC (EUROPE) N.V.** Keetberglaan 1, 2740 Beveren, Belgium TEL: 03/775-28-08.  
**PIONEER ELECTRONICS AUSTRALIA PTY. LTD.** 178-184 Boundary Road, Braeside, Victoria 3195, Australia  
TEL: (03) 580-9911

<85D00Y6Q03>

Printed in Japan <ARB-659-B>