

DIRECT DRIVE
STEREO TURNTABLE

PL-55DX

OPERATING INSTRUCTIONS

F

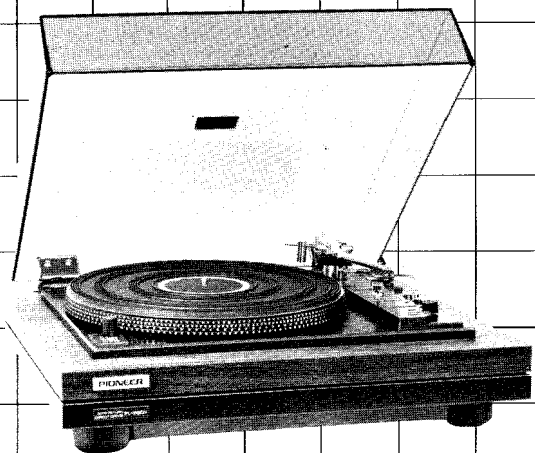

Pioneer wishes to thank you for deciding to purchase the PL-55DX, a direct drive stereo turntable. Please read this manual carefully, as it covers proper operating procedures and steps which will aid in obtaining maximum performance from this fine piece of equipment.

FEATURES

DIRECT DRIVE

Troublesome belts and idlers are not used. A DC servo motor drives the turntable directly. Design of this system limits transfer of vibration to the tonearm to an amazingly low level. PL-55DX gives performance a cut above that of comparable record players, and is sure to satisfy the most exacting audiophile.

ELECTRONIC SERVO CONTROL

Ambient temperature does not affect the speed of rotation, thanks to special electronic circuitry which maintains the motor speed at a constant value at all times. A touch of a button is the only requirement for setting this circuitry into operation. Speed switching is simple. Independent controls are used for fine adjustment of 33-1/3 and 45 rpm speeds. (Fine adjustment is effective within $\pm 2\%$ of the nominal speed.)

VERSATILITY

PL-55DX plays all four-channel records ... SQ, RM matrix records and CD-4 discrete records. Ordinary two-channel stereo records played on PL-55DX yield a marvelous four-channel effect. PL-55DX is sure to satisfy your listening requirements.

POSITIVE TRACKING

New design provides for simple adjustment of lateral balance of an S-shaped, statically balanced tonearm and includes an anti-ska ing device.

Stable tracking is guaranteed in all cases, including of course four-channel record playing and the use of cartridges featuring light tracking force.

STABLE OPERATION

A fully automatic mechanism linked to the function lever provides extra smooth tonearm operation, automatic return, and automatic interruption. There is never any need for concern over record or stylus damage.

NOVEL DESIGN

The outward appearance looks as well as turntable mechanism performs, matching other contemporary stereo system. Controls are grouped on the right side, for convenience.

CONTENTS

Features	2
Installation	2
Stereo System Structure.....	3
Line Voltage.....	4
Assembly.....	4
Connection to Stereo Amplifier	5
Tonearm Adjustments	6
Parts Identification	7
Dust Cover	7
Parts and Their Functions	8
Operation.....	9
Cautions on Playing Four-channel (CD-4) Records	10
Nomenclature and Use Cautions.....	10
Points to be Checked.....	10
Component Replacement.....	11
Specifications.....	12

INSTALLATION

Install the PL-55DX with the following points in mind.

- The place must be well-ventilated and free from humidity and dust.
- The unit should not be exposed to direct sunlight.
- The unit should not be placed near any source of heat.
- The unit should be placed as far from the speaker systems as possible.

STEREO SYSTEM STRUCTURE

FOUR-CHANNEL STEREO SYSTEM

Two-channel stereo system in which left and right speakers are located in front of the listener give breadth and presence to piano, violin, and vocal sounds. Four-channel stereo systems in which left and right speakers are located both to the front and rear of the listener (see accompanying illustration) add to these effects "depth," giving you the feel of a large space with associated reflections. All of the sound is there, natural and rich and "real."

Select a suitable four-channel stereo amplifier and speaker systems for your PL-55DX (Fig. 1).

TWO-CHANNEL STEREO SYSTEM

Connect a suitable two-channel stereo amplifier and speaker systems as shown in the accompanying illustration (Fig. 2).

NOTES ON SYSTEM STEREO COMPONENTS

Amplifier

Various four and two-channel configurations are available, including integrated stereo amplifier, pre-main stereo amplifiers, and preamplifier-power amplifier combinations. Selection is of course a matter of choice and budget. Pioneer recommends that you select a highly stable amplifier and matched speaker systems, which will insure a high performance level.

Speaker System

There are two types of speaker enclosures, the bass-reflexed type and the enclosed type. Speakers come in full-range, two-way, and three-way types. Again selection is a matter of choice and budget. In four-channel systems, it is advisable to use identical speakers at the four locations (front left and right, rear left and right). In any event, requirements call for matched front and matched rear speakers.

Phono Cartridge

Phono cartridge types include the magnetic type (moving coil type, moving magnet type, and induced magnet type), semiconductor type, and photoelectric type. If you wish to use a cartridge other than one furnished with the PL-55DX, a four-channel type should be selected so that you can play CD-4 records.

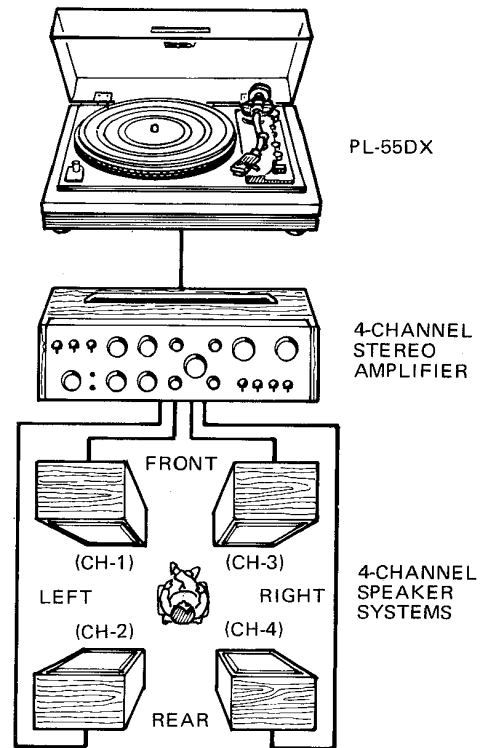

Fig. 1

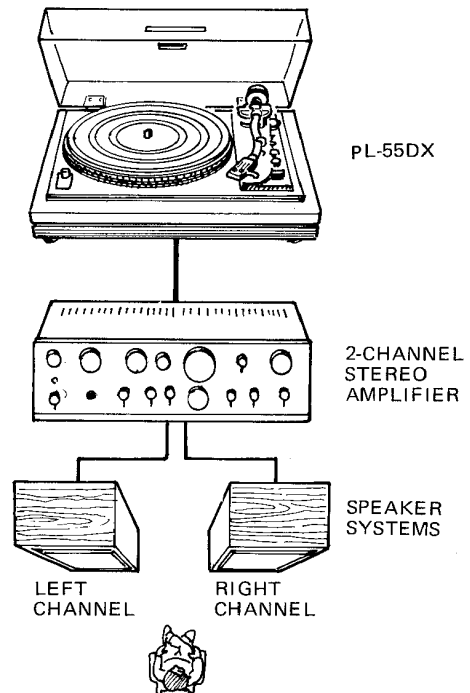

Fig. 2

LINE VOLTAGE

Confirm the line voltage of your house current before turning the power on, because your PL-55DX may not be conditioned for operation with your local line voltage. THE LINE VOLTAGE SELECTOR PLUG, provided inside the wooden base, can be seen when the bottom plate is removed (Fig. 3).

Your PL-55DX is set for operation at the voltage indicated by the caution card enclosed and/or on the carton box when shipped. If your house current voltage is different from the set voltage, regulate the line voltage for operation by yourself as follows:

1. Unscrew a total of 10 bottom plate-held screws as shown in Fig. 3.
2. Remove the bottom plate, and you can find the LINE VOLTAGE SELECTOR PLUG.
3. The cut-off of the selector plug shows the voltage which operates the unit. (Perhaps, it ought to be different from your local line voltage.)
4. Pull out the selector plug, and put it back as indicated in cut-off your house voltage 110V, 120V, 130V, 220V, or 240V (Fig. 4).

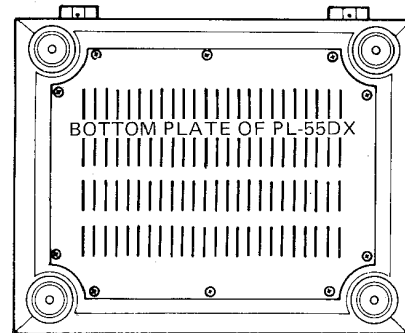

To remove bottom plate, unscrew a total of 10 screws.

Fig. 3

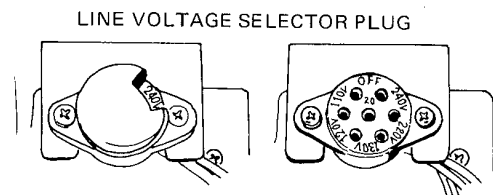

Fig. 4

ASSEMBLY

To prevent possible damage during transport, heavy items and delicate parts are packed separately. For assembling the PL-55DX, first read instructions through and proceed with great care never to touch the stopper near the center shaft as follows:

REMOVAL OF TONEARM PACKING

Remove packing (white) holding the arm, by opening it in the arrow-indicated direction as shown in the illustration (Fig. 5).

INSTALLATION OF TURNTABLE PLATTER

Unpack the turntable platter and place it over the center shaft. Lay the rubber mat on the turntable platter.

INSTALLATION OF HEAD SHELL

Fit the head shell to the end of the tonearm, securing it with the arm lock screw (Fig. 6).

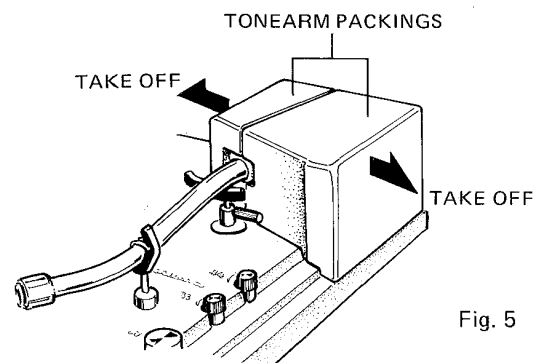

Fig. 5



Fig. 6

INSTALLATION OF MAIN COUNTERWEIGHT

Fit the main counterweight to the after end of the tonearm. Thread it in two or three turns in the arrow-indicated direction as shown Fig. 7.

INSTALLATION OF LATERAL WEIGHT

This component is included in the accessory parts box. Fit it to the bar and secure the weight screw (Fig. 8).

HEIGHT ADJUSTMENT OF ARM ELEVATOR

The arm elevator can be adjusted after loosening the little screw in its side (Fig. 9).

HEIGHT ADJUSTMENT OF ARM REST

The height of the arm rest is adjustable by first loosening the screw in its side, sliding the rest to the desired height, then tighten the screw again (Fig. 10).

- Readjustment of the arm rest and arm elevation is required when a different cartridge is used.

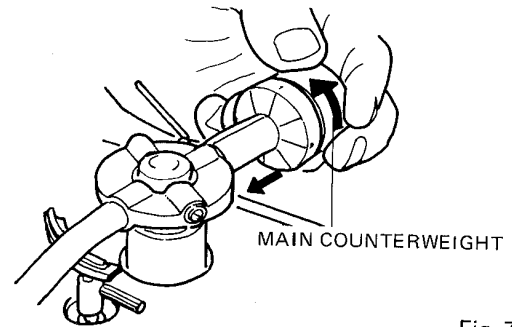

Fig. 7

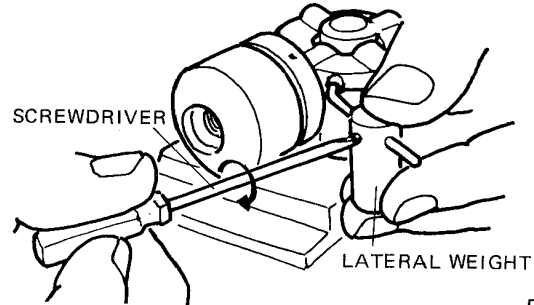

Fig. 8

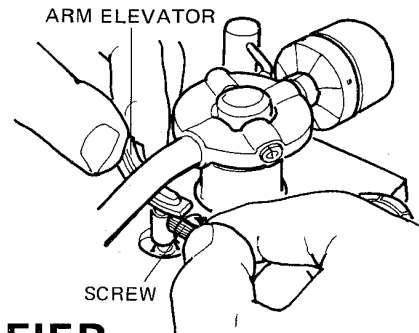

Fig. 9

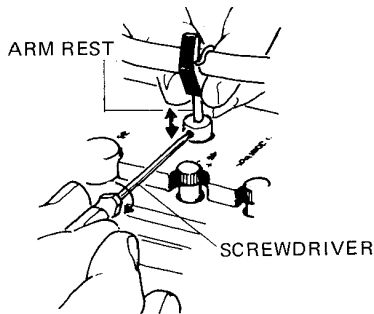

Fig. 10

CONNECTION TO STEREO AMPLIFIER

The cartridge furnished with PL-55DX is of the induced magnet type (PC-Q1). Connection should be made to PHONO MAG of the stereo amplifier. If four-channel (CD-4) records are to be played, make connections in accordance with the four-channel amplifier instructions manual.

- Connect PL-55DX leads to PHONO MAG of the stereo amplifier. Be sure to observe L(Left) and R(Right) markings (Fig. 11).
- The lead with a split lug at its end is the ground lead. Connect this lead between the stereo amplifier's GND terminal and PL-55DX's E terminal (Fig. 11).

NOTE:

If a low-output moving coil (MC) cartridge is to be used, it will be necessary to add a special matching transformer or an amplifier which has provision for connection of this type of cartridge.

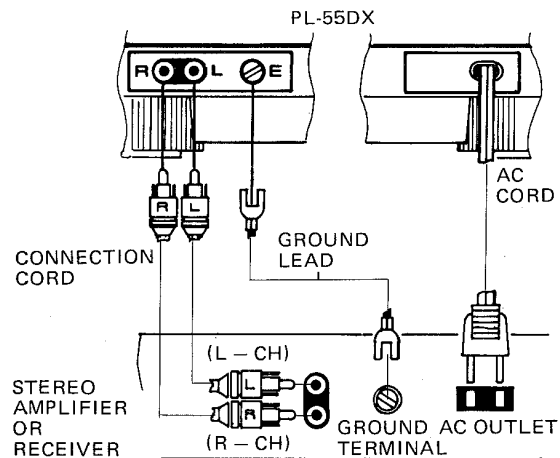

Fig. 11

TONEARM ADJUSTMENTS

LATERAL BALANCE

Refer to the accompanying illustration. Make sure that the lateral weight is 10 ~ 15mm from the end of the bar. This setting also applies when nonstandard cartridges are used. Make sure that the attitude of the turntable itself is horizontal (Fig. 12).

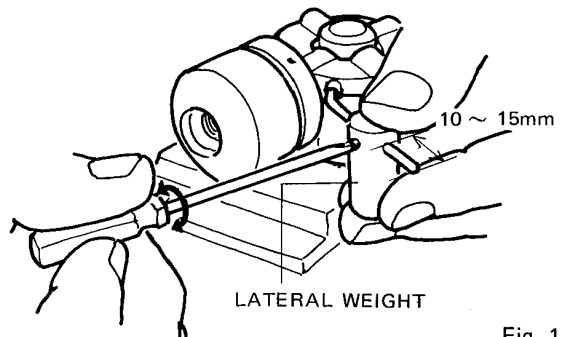

Fig. 12

HORIZONTAL BALANCE

Set the anti-skating device knob to "0". Remove the stylus cover. Turn the main counterweight, obtaining horizontal balance for the tonearm. (That is, locate the main counterweight so that the tonearm remains in a horizontal attitude with respect to the head and weight ends.)

Now turn the tracking force counter ring at the forward end the main counterweight, matching the 0-position to the index line (black) inscribed on the tonearm. Note that the main counterweight must be held at this time, to keep it from turning as the counter ring is turned (Fig. 13).

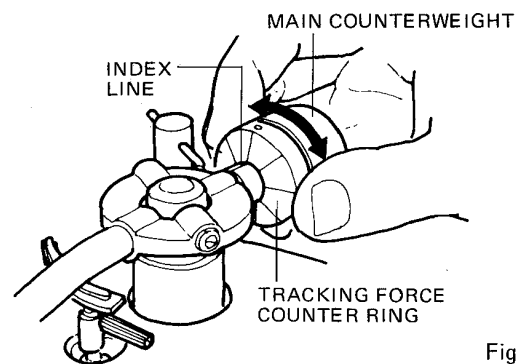

Fig. 13

TRACKING FORCE

Earlier adjustment set stylus pressure to zero. At this time, turn the main counterweight to the position at which the tracking force as indicated by markings on the counter ring is that desired. (Turning the main counterweight carries along the counter ring.) The counter ring is graduated in 0.5g increments and provides 4 grams of adjustment per turn (Fig. 14).

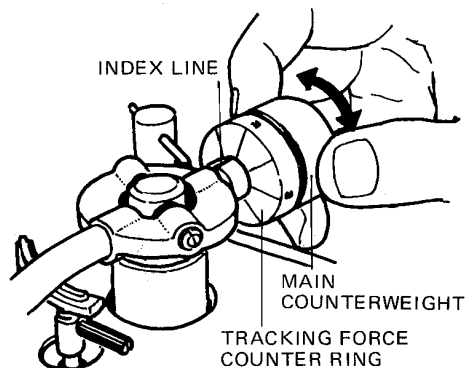

Fig. 14

ANTI-SKATING FORCE

Turn the anti-skating device knob to the position which matches tracking force (Fig. 15).

Example: If tracking force is 1.8g, set this knob to 1.8.

What is "Anti-skating"??

As the record groove moves in relation to the stylus it exerts a force on the stylus which pushes it toward the center shaft of the record. This is called "skating force" and will actually cause the stylus to jump out of the groove and "skate" if it is too strong. Even when this does not occur, the force distorts the sound response. The anti-skating device is designed to cancel this force.

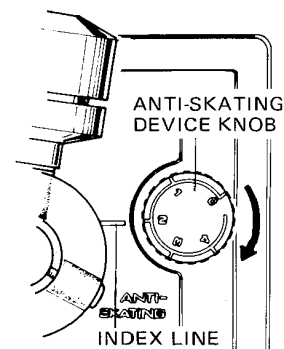
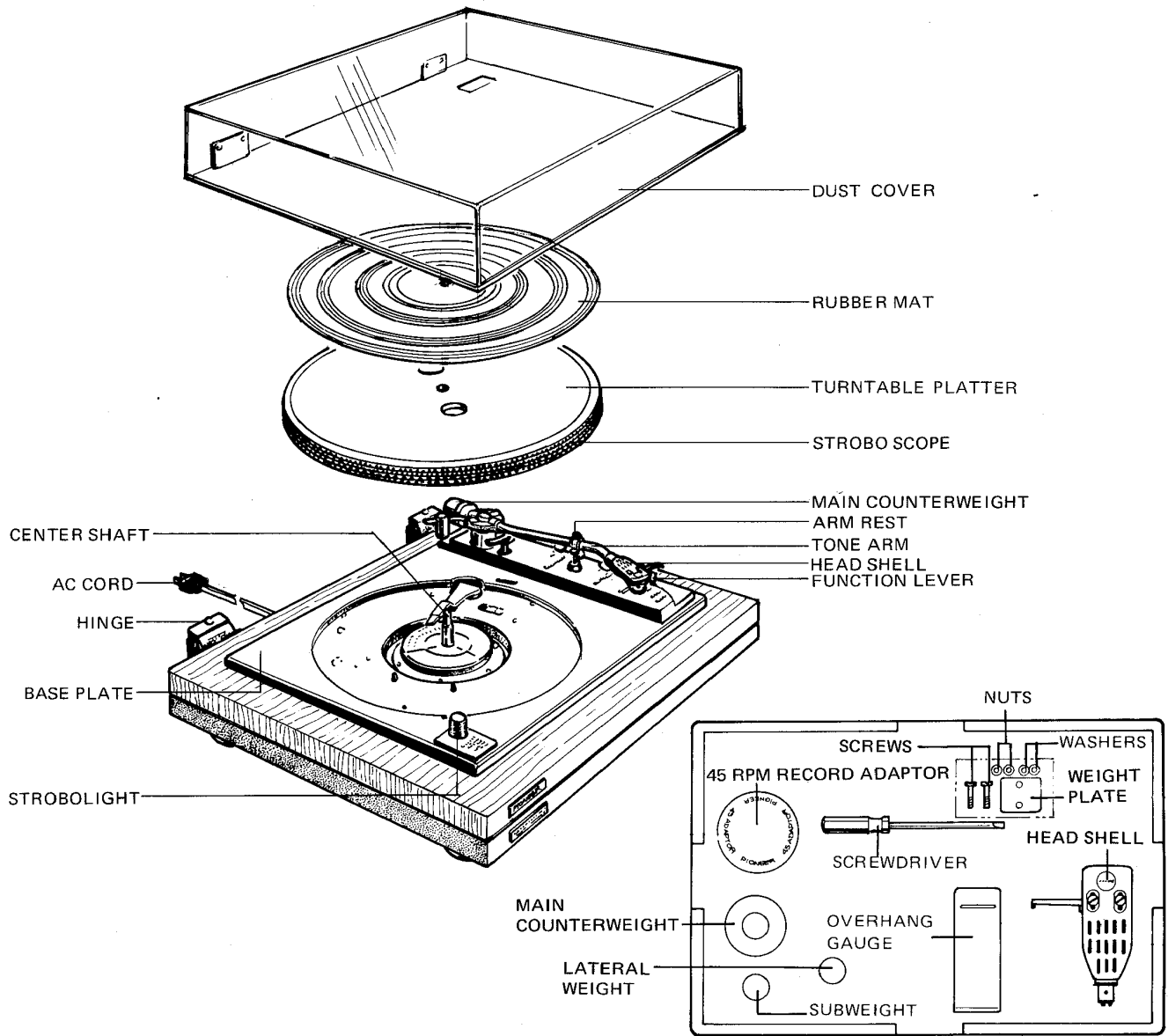

Fig. 15

PARTS IDENTIFICATION



DUST COVER

See the accompanying illustration. Align the dust cover (made of acryl) to turntable hinges and shift it to the side to lock it in place (Fig. 16).

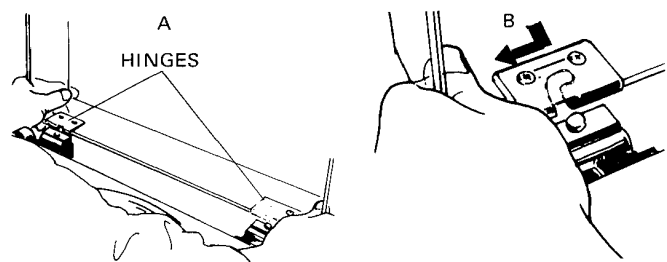
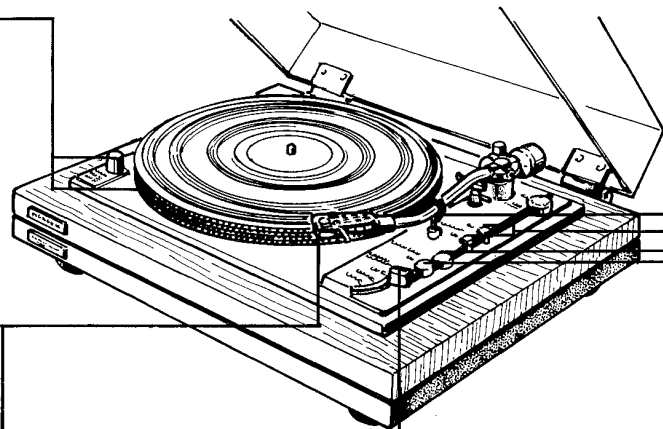
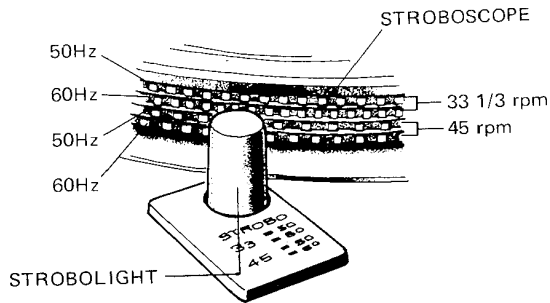

Fig. 16

PARTS AND THEIR FUNCTIONS

Stroboscope

Refer to the accompanying illustration for positioning of the strobo in respect to the line frequency and turntable speed. On moving the function lever from OFF to ON/UP and DOWN, strobolight is lit.



Function Lever

At ON/UP

The turntable is driven. In moving this lever from DOWN to this position, the tonearm (stylus) lifts slowly from the record surface, thereby interrupting operation.

At DOWN

The tonearm is brought into position over the record. Setting the lever to this position gently lowers the stylus onto the record. Playing starts at this time.

At OFF

Moving the lever to this position from DOWN causes the tonearm to lift and return to the arm rest. Power is cut off and the turntable stops.

NOTES:

1. On moving the function lever from DOWN to OFF pause at the ON/UP position until the arm lifts from the record. Failure to do so may allow the stylus to bounce against the record and drag across it.
2. Also once you have moved the function lever to DOWN you cannot immediately return it to OFF or ON/UP.
3. Wait until the tonearm has floated down on the record and begun to play. Only then may playing be interrupted.

Cartridge Stylus Cover

Bring the cartridge stylus cover into position when the PL-55DX is not in use as shown in the accompanying illustration.

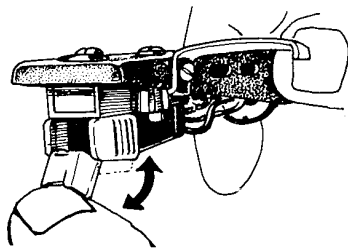

45 rpm Record Adaptor

A 45 rpm record adaptor is supplied in the accessory group, which permits 45 rpm EP records with large center holes to be played.

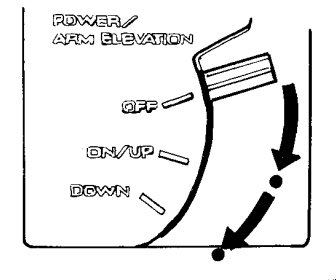
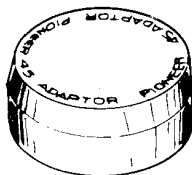

Arm Rest

The arm rest supports the tonearm. The tonearm should always sit on the arm rest when a record is not in use.

Ordinarily, the arm clamp should be engaged to lock the tonearm in place on the rest.

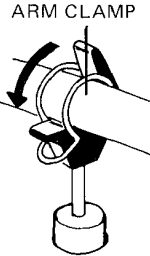

Fine Speed Adjustment Knob

With the turntable operating at 33-1/3 or 45 rpm, make fine speed adjustment while observing the stroboscope. Turning the knob in the (+) (clockwise) direction increases speed while turning it in the (-) (counterclockwise) direction decreases speed. Marks on the turntable must appear to "stand still" under strobolight, indicated correct speed.

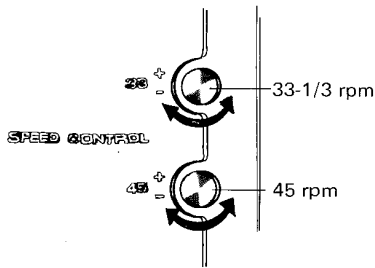

33-1/3 rpm Speed Switch

Push this switch if 33-1/3 rpm records are to be played.

45 rpm Speed Switch

Push this switch for 45 rpm operation.

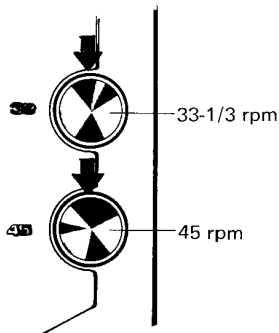

OPERATION

Operation of the PL-55DX is uncomplicated. Use the following procedure.

1. Place the record to be played on the turntable.
2. Move the cartridge stylus cover out of position. Release the arm rest clamp.
3. Move the function lever from OFF to ON/UP. At this time, the turntable begins to turn.
4. Push the speed button (33-1/3 or 45 rpm) corresponding to the speed of the record to be played.
5. With the strobolight on, adjust the fine speed control until the turntable appears to "stand still". Turning this control in the (+) direction raises the speed, while turning it in the (-) direction decreases the speed.
6. After the speed has been set the proper value, carefully move the tonearm into position over the lead-in record grooves and to be played.
7. Set the function lever to DOWN. The tonearm drops gently to the record grooves and playing begins.
8. To stop playing at an intermediate point, move the function lever to ON/UP. If operation is to be suspended, move the function lever to OFF. (This action returns the tonearm to the arm rest and stops the turntable).
9. Upon completion of playing, the tonearm returns automatically to the arm rest and the turntable stops. The function lever returns automatically to OFF.

Always turn the power on after placing the turntable platter on the center shaft.

CAUTIONS ON PLAYING FOUR-CHANNEL (CD-4) RECORDS

TRACKING FORCE ADJUSTMENT

The cartridge employed has frequency response superior to that of an ordinary stereo phono cartridge, in order to provide faithful reproduction of the indicated CD-4 record grooves. Therefore, the permissible range of tracking force is quite narrow. Tracking force falling outside the acceptable range will cause poor sound reproduction quality. Always use only the specified tracking force.

INSTALLATION OF CARTRIDGE AND HEAD SHELL

The cartridge and head shell must be installed so that the stylus is level to the record surface. Check this point carefully.

CLEANING DISK

The four-channel (CD-4) record has delicate record grooves.

Keeping the disk clean is even more important than in the case of ordinary stereo records, as a result. Using a quality cleaner, carefully clean CD-4 records before and after use.

Do not use spray type solvents or water for cleaning.

CLEANING STYLUS

A certain amount of dirt will accumulate at the stylus tip during the playing operation. This accumulation will harden if it is left in place, deteriorating reproduced sound and eventually interfering with reproduction itself. Clean the stylus tip each time you use the turntable.

NOMENCLATURE AND USE CAUTIONS

HORIZONTAL ATTITUDE

Failure to position the turntable in a horizontal attitude will lead to a number of problems. Check positioning.

ALWAYS KEEP STYLUS CLEAN

Accumulation of dirt particles at the stylus tip deteriorates the quality of reproduced sound. Always keep stylus tip clean with a soft brush. Always keep record surfaces clean with a suitable record cleaner before each play, otherwise delicate stereo sound quality will be deteriorated. Never touch the stylus tip, as the stylus can be damaged.

VIBRATION

As the cartridge used has a light tracking force, it is imperative that the turntable be located so as to be free of the effects of vibration. Keep the turntable well away from speaker systems and other sources of vibration.

INTERNAL WORKINGS

The PL-55DX is a precision device. Refrain from removing the cover and turntable from "tampering" with internal parts.

POINTS TO BE CHECKED

HUM

Hum is often caused by power line frequency, either from poor grounding or poor connections as follows:

- Turntable ground not connected to amplifier ground.
- Turntable output cable in close proximity to amplifier power transformer.
- It may be possible to eliminate hum by reversing the AC cord at the power line socket.

ACOUSTICAL FEEDBACK

Feedback occurs when speaker vibration is sensed by the pickup cartridge. Resulting sound takes the form of a hum. Raising the sound level causes the stylus to jump.

To eliminate this problem, separate the turntable and speakers to a greater extent.

COMPONENT REPLACEMENT

STYLUS

The standard cartridge PC-Q1 has a diamond stylus (PN-Q1).

Nominal service life of the stylus is 400 to 600 playing hours. Attempting to use a stylus beyond this limit will result in record damage and poor sound quality. To replace the stylus, remove the head shell from the tonearm and carefully extract the stylus (at an angle from above) (Figs. 17, 18). Reverse this procedure to install the new stylus.

Obtain replacement stylus (PN-Q1) from any Pioneer sales outlet. Refrain from using stylus of other manufacturers. In the event that other styli are used, Pioneer cannot assume any responsibility for problems which arise.

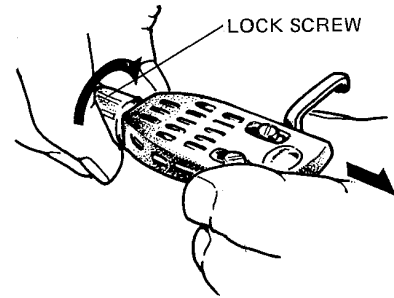

Fig. 17

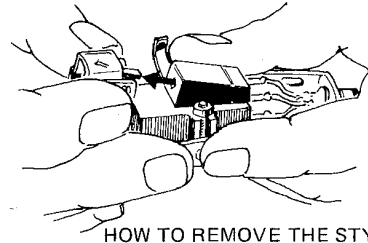

Fig. 18

CARTRIDGE

Connector terminals conform to international standards. In replacing the cartridge, make sure that head leads are connected to proper points (Fig. 19). Temporarily secure the cartridge, then check overhang, and finally secure the cartridge firmly. Refer to the accompanying illustration for information on adjusting overhang (Fig. 20).

CARTRIDGE WEIGHT AND SUBWEIGHT

If a heavy cartridge is used, weight of the main counterweight may not be sufficient to balance the tonearm. In this case, add the subweight to the rear end of the main counterweight and adjust balance (Fig. 21).

If a light cartridge is used, it may be necessary to insert the weight plate between the head shell and cartridge in order to balance the tonearm.

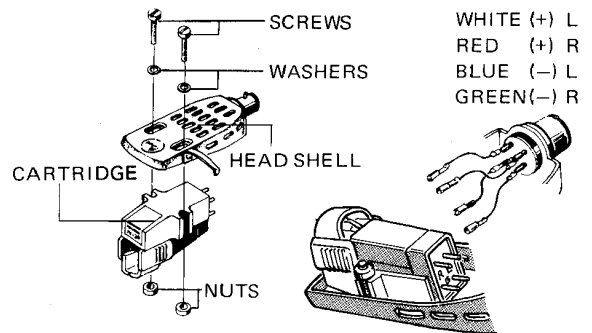

Fig. 19

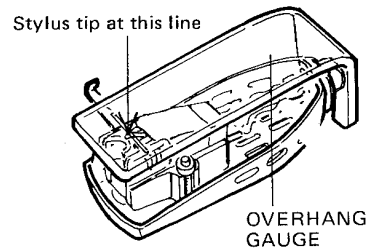

Fig. 20

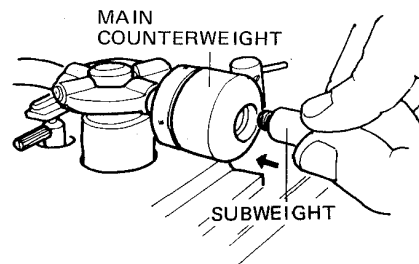

Fig. 21

SPECIFICATIONS

Motor and Turntable

Motor: Brushless DC servo motor
 Turntable drive: Direct-driven
 Speed: Two speeds, 33-1/3, 45 rpm
 Wow and flutter: 0.05% (WRMS) or less
 S/N: 58dB or more (in case of using Pioneer cartridge model PC-Q1)
 Turntable platter: 31cm diam. Aluminum-diecast alloy

Tonearm

Tonearm type: Static balance, S-shaped, pipe arm
 Effective arm length: 221mm
 Usable cartridge weight: 4g (MIN) to 14g (MAX)
 Overhang: 15.5mm

Subfunctions

Automatic return tonearm system
 Skating force canceler
 Hydraulic cueing device
 Plug-in type light aluminum head shell
 Dust cover with free stop hinges
 Wooden base with anti-acoustic feedback suspension
 Strobolight

Miscellaneous

Power requirements: AC 240V, 220V, 130V, 120V or 110V, 50/60Hz
 Power consumption: 5.2W (MAX)
 Outer dimensions: 480(W) x 410(D) x 185(H)mm
 18-7/8(W) x 16-1/8(D) x 7-5/16(H) in.
 Weight: 11.2 kg 24lb 10oz

Accessories

Weight plate (cartridge weight adjustable)	1
Cartridge mounting screws	10
Cartridge mounting nuts	2
Cartridge mounting washers	2
45rpm record adaptor	1
Screwdriver	1
Sub weight	1
Overhang gauge	1
Connection cord	1
Operating instructions	1

Furnished Cartridge

Type: Induced magnet type
 Frequency response: 10 to 50,000Hz
 Channel separation: More than 25dB at 1,000Hz
 Output voltage: 2mV at 1,000Hz (50mm/sec or 2 inches per second)
 Load impedance: 100kΩ
 Compliance: 10x10⁻⁶cm/dyne at 100Hz
 Stylus for replacement: PN-Q1
 Tracking force: 1.0 ~ 2.1g (proper 1.8g)
 Weight: 5.5g
 Stylus point: Pathemalcony type
 Mounting: Conforms to the EIA standards

NOTE:

Specifications and the design subject to possible modification without notice due to improvements.

PIONEER ELECTRONIC CORPORATION

4-1, 1-Chome, Meguro, Meguro-ku, Tokyo 153, Japan

U.S. PIONEER ELECTRONICS CORPORATION

75 Oxford Drive, Moonachie, New Jersey 07074, U.S.A.

PIONEER ELECTRONIC (EUROPE) N.V.

Luithagensteenweg, "De Meermin", 2030 Antwerp, Belgium.

PIONEER ELECTRONICS AUSTRALIA PTY. LTD.

178-184 Boundary Road, Braeside, Victoria 3195, Australia

Printed in Japan