

INTEGRATED STEREO AMPLIFIER

# SA-6300

OPERATING INSTRUCTIONS

FP  
FV  
GN

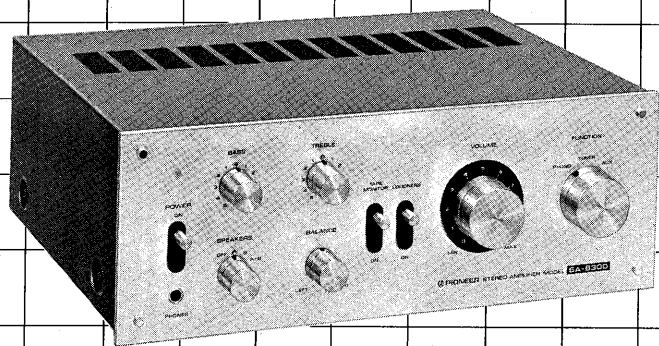

## CONTENTS

<p>Features ..... 2</p> <p>Stereo System Set-up ..... 3</p> <p>Speaker Connection ..... 3</p> <p>Connection Diagram ..... 4</p> <p>Connections ..... 5</p> <p>Front Panel Facilities ..... 6</p>	<p>Before Operation ..... 7</p> <p>Operation ..... 7</p> <p>Employing Tape Deck ..... 8</p> <p>Checking Operating Procedure ..... 9</p> <p>Conditions Frequently Mistaken for Malfunction ..... 10</p> <p>Specifications ..... 11</p>
--	---

## FEATURES

### Power to Spare for Low Distortion

The pure complementary OCL circuitry employs high reliability NPN and PNP silicon power transistors, a differential first stage and direct coupling at all stages. The result is superb frequency response, output bandwidth and distortion characteristics. 20W per channel provides ample reserves of power for rich and stable stereo reproduction.

### IC Equalizer Section

RIAA deviation, the most important factor in record reproduction, is minimized by the IC equalizer section to provide advanced fidelity. Transistorized constant current circuits are employed throughout, increasing the acceptable dynamic margin. Low distortion record playback, with a wide dynamic range, can thus be enjoyed.

### All Program Sources can be Played

The rear panel is provided with special input jacks for turntable, tuner and tape deck, plus AUX jacks for cartridge tape player deck, etc. Virtually all program sources can be enjoyed.

### Accepts 2 Sets of Speaker Systems

The SA-6300 is equipped with 2 sets of speaker terminals and a speaker selector switch. Comparison listening of 2 speaker systems, or simultaneous operation of speakers in different rooms can be performed by single switch selection.

### New Design Underscores Performance Quality

Simple, elegant front panel design provides built-in operational ease. A matching stereo tuner is also available for composing an easy to use high performance stereo system.

## LINE VOLTAGE AND FUSE

SA-6300 amplifiers are designed to accept different line voltages, according to the country in which they are to be used, although the operation of the various models is the same in every other respect. The line voltage connection is on the rear panel.

Fig. A shows the line voltage connection of a model designed to operate at 220V only.

Fig. B shows the line voltage selector and fuse of a model designed to operate at any of five preselected voltages (110V, 120V, 130V, 220V, 240V).

## Changing Line Voltage Setting and Fuse

To remove the fuse, unscrew the fuse cap located in the center of the line voltage selector and withdraw it, together with the fuse. Next, pull the line voltage selector plug out of its socket, rotate it until the cutaway aligns with the appropriate line voltage marked on the back of the unit, then push it back into its socket. It is important to check the rating of the fuse; a 1.5A fuse should be used with either 220V or 240V, while a 3A fuse should be used for 110V, 120V or 130V operation. If the fuse rating is correct, replace it and screw in the fuse cap.

### Fuse Replacement

When the fuse blows, remove the fuse cap and replace the fuse with a new one. Fig. C.

220V (GN) MODEL ONLY

5-LINE VOLTAGE MODEL

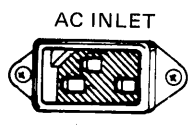

Fig. A

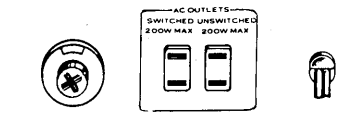

Fig. B

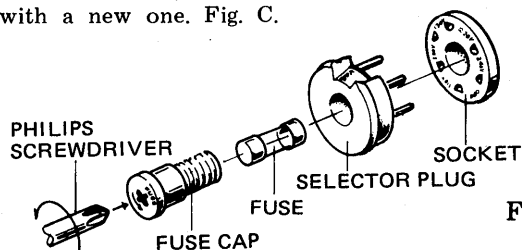

Fig. C

## STEREO SYSTEM SET-UP

The SA-6300 is an integrated stereo amplifier, meaning that it combines a pre-amplifier and power amplifier in one unit. For your stereo system, you will need at least one pair of speaker systems and one program source such as a turntable, a stereo tuner, or a tape deck. These should be of comparable high quality to the SA-6300.

### INSTALLATION CAUTIONS

Avoid installing the SA-6300 in locations such as the following.

- In direct sunlight, near radiators or other heat sources.
- Humid or dusty surroundings.
- Unlevel or unstable supports, or where subject to vibration.

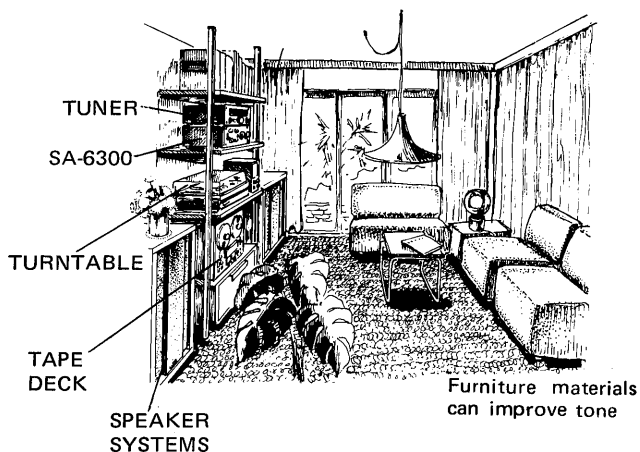

Fig. 1

## SPEAKER CONNECTION

The SA-6300 is provided with 2 sets of speaker output terminals, A and B. A pair of speakers should normally be connected to the A terminals.

- As shown in Fig. 2, connect the right channel (as viewed from the front) speaker to the R terminals, and the left channel speaker to the L terminals.
- Observe plus (+: red) and minus (-: black) polarities of the output terminals and those of the speakers. When making connections take care to connect + to + and - to - between the speakers and the SA-6300 speaker terminals.

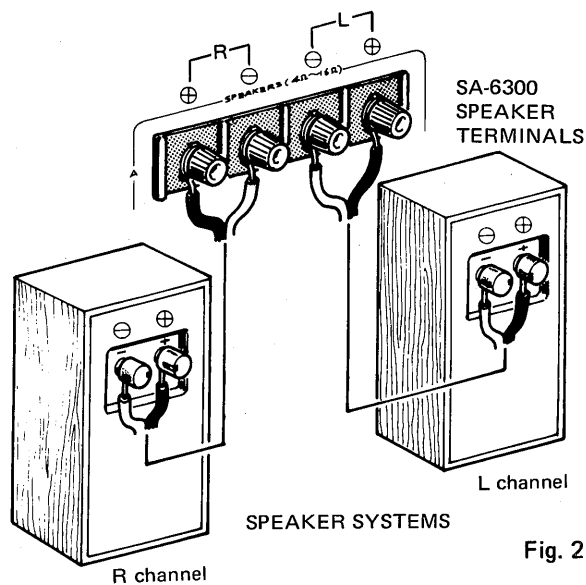

Fig. 2

**NOTE:**

*If 2 sets of speaker systems (A & B) are to be used simultaneously, be sure that all speaker systems are 8Ω or more in impedance. Damage may be caused if speakers of less than 8Ω are employed.*

### A WORD ABOUT ROOM ACOUSTICS

The sound heard from an audio system is greatly influenced by conditions in the listening room. The size and shape of the room, materials composing the walls, ceiling and floor, the amount and distribution of furniture, carpets, draperies, etc. all affect the resulting sound. In general it is advisable to place speakers with their backs against a wall, as this will improve bass response.

Bare rooms with low ceilings, hard floors and hard, reflective walls (especially a hard wall facing the speakers) can produce an excessively "live" brilliant sound with lack of clear instrument localization and definition. It often helps in such cases to place a carpet and heavy, soft curtains in the room. Conversely, a "dead" sound can be caused in rooms containing heavy carpeting and a large amount of upholstered furniture. This can often be improved by re-arranging the furniture.

# CONNECTION DIAGRAM

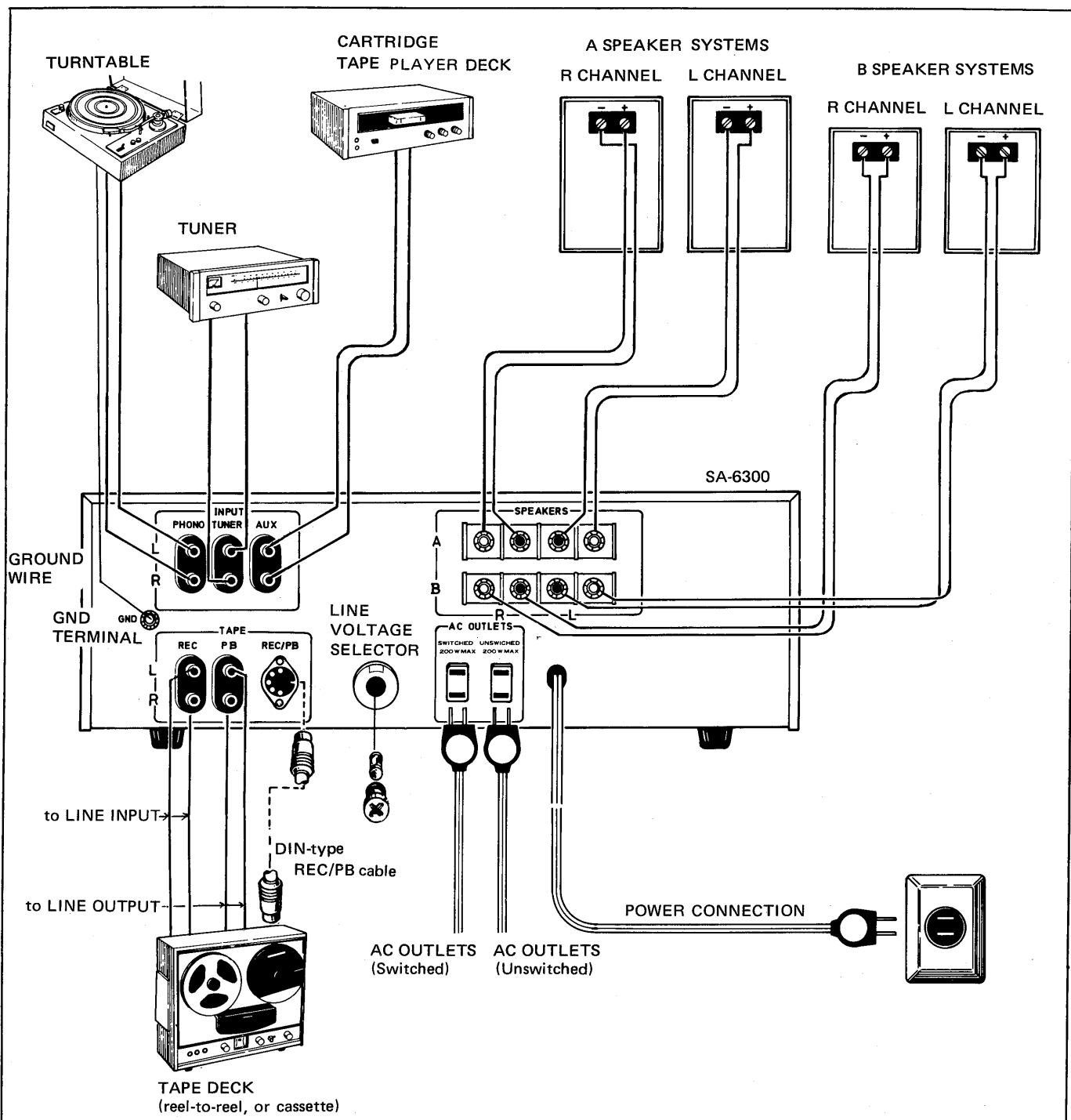

## CAUTIONS WHEN CONNECTING

- Observe both the channels and polarities of the inputs and outputs of the components connected to the SA-6300. Be sure to connect L to L, R to R, + to +, and - to -.
- Make all connections securely. Loose connections can cause noise or loss of sound.

## USING AC CONVENIENCE OUTLETS

These can be used to supply AC power to other components, such as turntable, tape deck, etc.

**SWITCHED:** AC power to a component plugged into this outlet is coupled with the SA-6300 switch setting. Maximum 200W.

**UNSWITCHED:** AC power is always present at this outlet regardless of POWER switch setting. Maximum 200W.

# CONNECTIONS

## TURNTABLE

Connect turntable outputs to the PHONO jacks, and ground wire to the GND terminal.

**NOTE:**

A moving magnet (MM) type cartridge can be directly connected; however, a low output moving coil (MC) cartridge requires an accessory matching transformer or head amplifier.

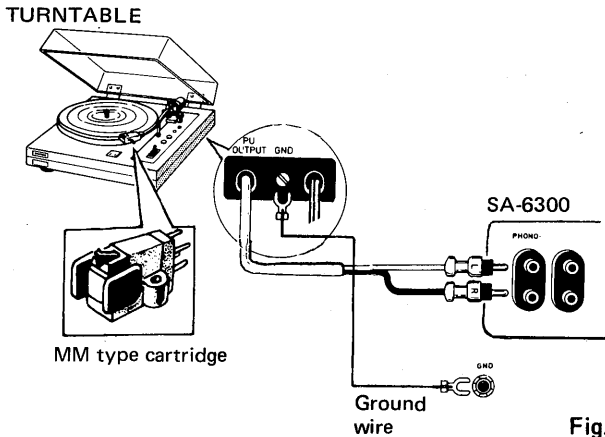

Fig. 3

## TUNER

Connect an AM/FM stereo tuner to the TUNER jacks.

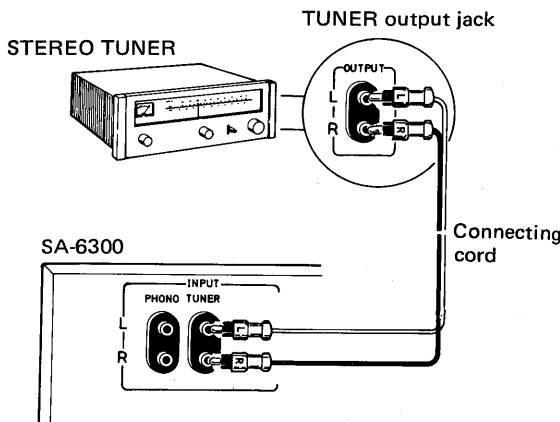

Fig. 4

## AUX TERMINALS

These jacks are for auxiliary inputs. They can be used to connect a cartridge tape player deck, second tuner, or other source.

## TAPE DECK (Reel-to-reel or Cassette)

The SA-6300 can be connected to a stereo tape deck (reel-to-reel, cassette) for recording and playback. Connecting cords are usually supplied with the tape deck. Connect as follows:

### Recording Connections

Connect tape deck recording terminals (LINE INPUT) with the TAPE REC jacks.

### Playback Connections

Connect the tape deck playback terminals (LINE OUTPUT) with the TAPE PB jacks.

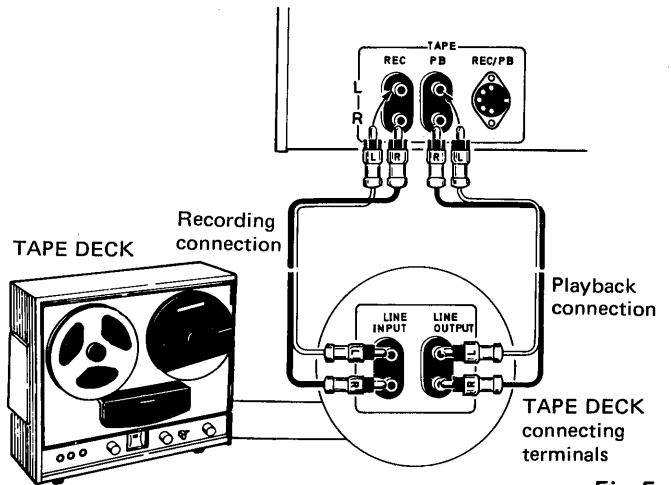

Fig. 5

### Connection Via REC/PB Connector

Instead of the recording and playback connection just described, the tape deck can be connected to the TAPE REC/PB connector (DIN type) of the SA-6300 provided an identical connector is fitted to the tape deck. The single DIN-cable completes all playback and recording connections at the same time.

Note that the REC/PB connector corresponds to TAPE PB and TAPE REC jacks — the signal must be controlled by means of the TAPE MONITOR switch on the SA-6300.

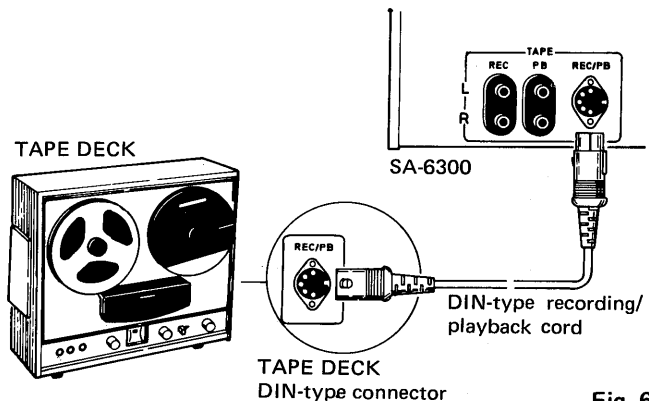

Fig. 6

# FRONT PANEL FACILITIES

## POWER Switch

Switch for turning AC power ON-OFF.

## Pilot Lamp

Lights to indicate power on.

## BASS & TREBLE Controls

Tone controls for low and high frequency sounds. Clockwise rotation from center enhances, while counter-clockwise rotation reduces bass or treble.

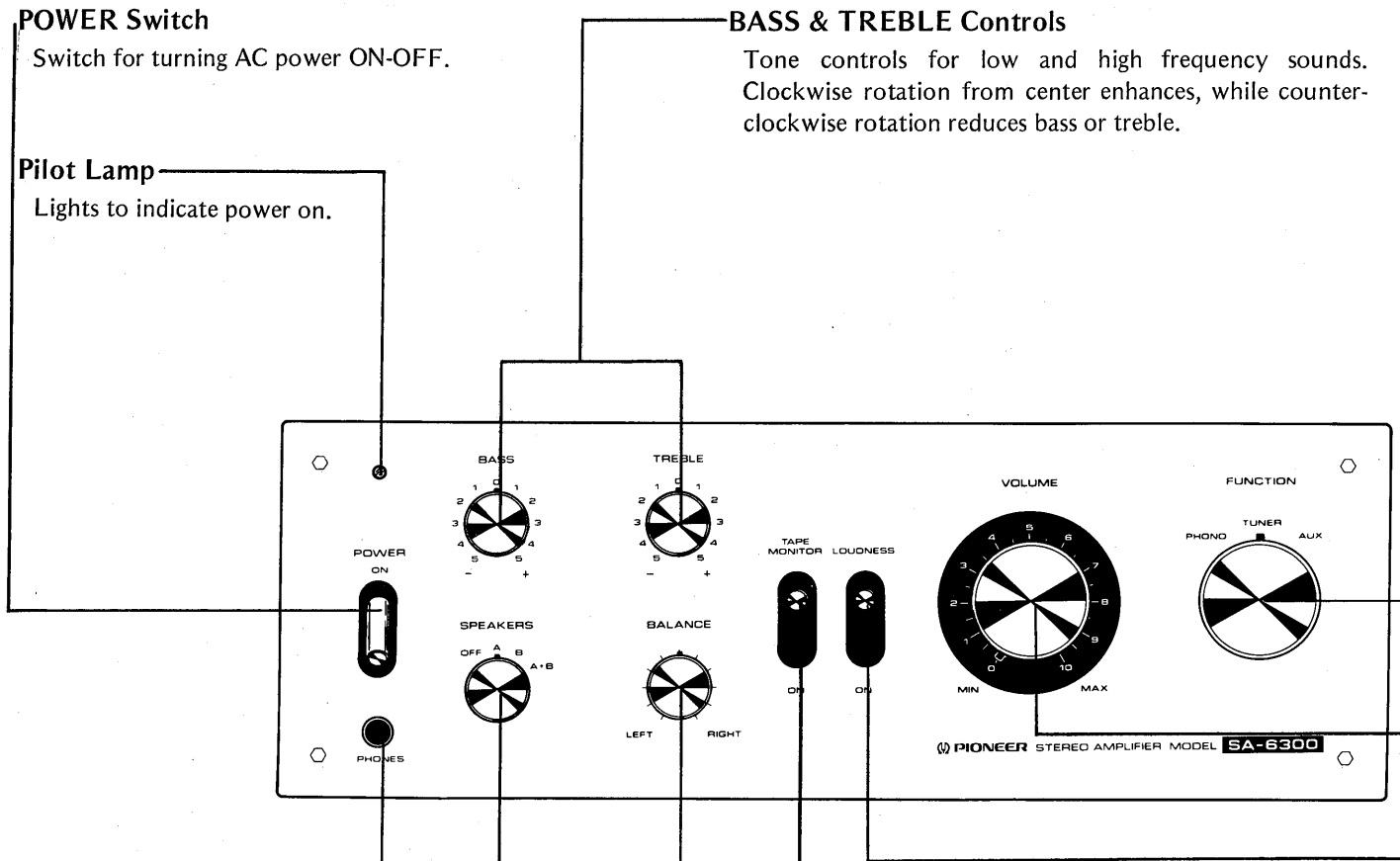

## PHONES Jack

Stereo headphones can be plugged into this jack for private listening. Set the SPEAKERS switch to OFF when using headphones.

## SPEAKERS Switch

Switch for selecting speaker systems

- OFF: Cuts off sound from speakers (when using headphones only)
- A: Sound obtained from the pair of speaker systems connected to the A speaker terminals.
- B: Sound obtained from the pair of speaker systems connected to the B speaker terminals.
- A + B: Sound obtained from both A and B speaker systems.

## TAPE MONITOR Switch

Set to ON when using a tape deck for tape playback, or when monitoring a tape during recording.

### NOTE:

*Except for tape playback, keep this switch in the up (OFF) position.*

## BALANCE Control

Control for adjusting volume balance between left and right speakers and headphones. Clockwise rotation from center increases right channel volume, while counter-clockwise rotation increases left channel volume.

## BEFORE OPERATION

Before setting the POWER switch to ON, set the other controls and switches as follows:

- VOLUME control to MIN.
  - TAPE MONITOR switch to upper position(OFF).
  - BALANCE control to center position.
  - LOUDNESS switch to upper position.
  - BASS & TREBLE controls to 0 (center position).
  - SPEAKERS switch to the desired position.
- Now you can turn the POWER switch ON.

## OPERATION

### PLAYING RECORDS

1. Set the FUNCTION switch to PHONO.
2. Play record on the turntable.
3. Adjust the VOLUME, BASS and TREBLE controls for desired volume and tone.

#### NOTES:

- Lower the tonearm stylus gently onto the record. Temporarily lowering the VOLUME control will reduce the noise which sometimes occurs when the tonearm touches down.
- Do not turn off the power while the stylus is in contact with the record.
- Avoid imparting vibration to the turntable while a record is being played. This may cause the stylus to jump and possibly damage the record.
- Howling may be caused if the turntable is too close to the speaker systems. Allow for adequate spacing when installing.

### EMPLOYING TUNER

1. Set the FUNCTION switch to TUNER.
2. Tune in the desired station on the tuner.
3. Adjust the VOLUME, BASS & TREBLE controls for desired volume and tone.

### EMPLOYING AUX COMPONENTS

Auxiliary program sources, such as a cartridge tape player deck, can be connected to the AUX jacks.

1. Set the FUNCTION switch to AUX.
2. Operate the program source.
3. Adjust the VOLUME, BASS & TREBLE controls for desired volume and tone.

### FUNCTION Switch

Switch for selecting desired program source.

PHONO: To play record on turntable connected to the PHONO jacks

TUNER: To employ tuner connected to the TUNER jacks

AUX: To employ program source connected to the AUX jacks.

### VOLUME Control

Control for adjusting volume from speakers and headphones. Clockwise rotation increases volume.

### LOUDNESS Switch

Set switch to ON to enhance low and high frequencies when listening at low volume.

The human ear possesses differing response to sound at high and low volume levels. This switch compensates for these characteristics.

# EMPLOYING TAPE DECK

## TAPE PLAYBACK

As shown in Fig. 7, the tape deck is connected to TAPE PB jacks.

1. Set the TAPE MONITOR switch to ON.
2. Play tape on tape deck.
3. Adjust the VOLUME, BASS & TREBLE controls for desired volume and tone.

**NOTE:**

Turning the TAPE MONITOR switch ON enables tape playback whatever the setting of the FUNCTION switch.

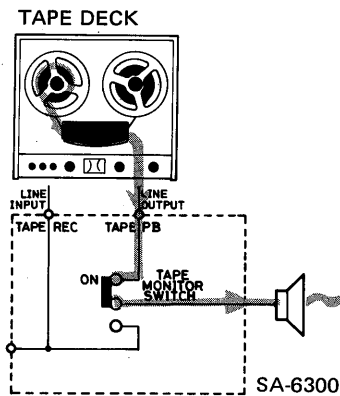

Fig. 7

## TAPE RECORDING

As shown in Fig. 8, the tape deck is connected to TAPE REC jacks.

1. Set the FUNCTION switch to the source to be recorded (PHONO, TUNER, etc.).
2. Operate the program source.
3. Adjust recording levels with the tape deck controls and proceed with recording.

**NOTE:**

The SA-6300 VOLUME, BASS & TREBLE controls have no effect upon the signal at the TAPE REC jacks. The signal is recorded as it comes from the program source and must be adjusted with the controls on the tape deck.

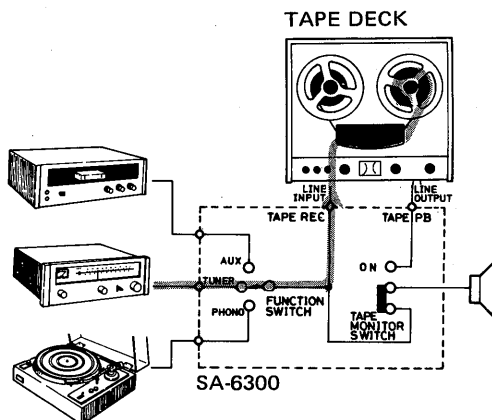

Fig. 8

## Monitoring Recording Conditions

If the tape deck is a 3-head type recording conditions can be monitored through the speakers or headphones by setting the TAPE MONITOR switch to ON. Both recording and playback connections must be made in this case.

## TAPE DUPLICATION AND EDITING

By employing two tape decks, selected material from a previously recorded tape can be edited onto a second tape. A personal tape library can be compiled in this manner.

1. Connect two tape decks as shown in Fig. 9.
  2. Set the FUNCTION switch to AUX, and operate the tape deck connected to the AUX jacks as the program source.
  3. Record the program onto the tape deck connected to the TAPE terminals, controlling the recording level by means of the controls on that deck.
- To monitor the recording while duplicating set the TAPE MONITOR switch to ON.

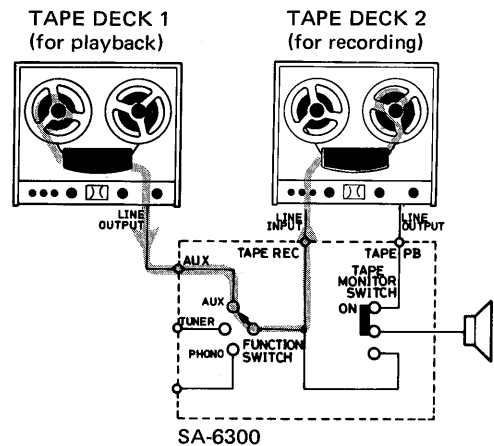

Fig. 9



# OPERATION REFERENCE GUIDE

## SWITCH and BUTTON POSITIONS

### Record Playing

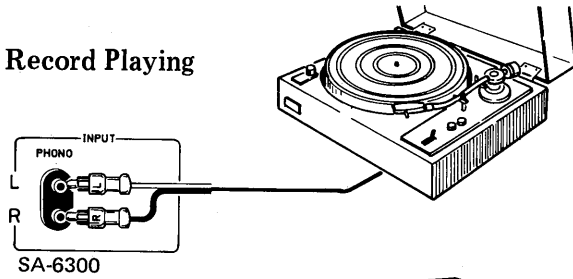

FUNCTION

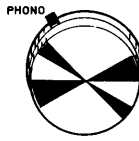

TAPE MONITOR



ON

- Set the SPEAKERS switch according to the connected speaker terminals.
- Adjust volume and tone with the VOLUME, BASS, TREBLE controls of the SA-6300.

### Broadcast Reception

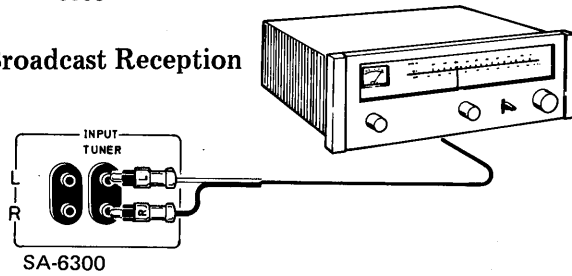

FUNCTION



TAPE MONITOR



ON

### Using AUX Terminals

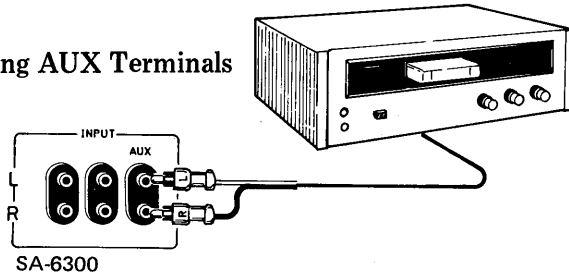

FUNCTION



TAPE MONITOR



ON

### For Playback

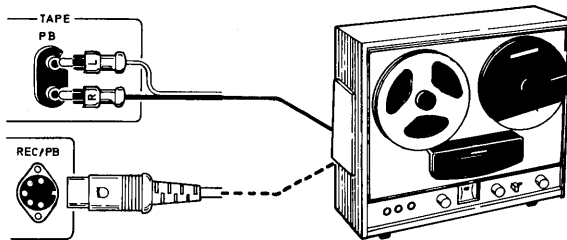

TAPE MONITOR



ON

- Set the TAPE MONITOR switch to ON
- Adjust volume and tone with the controls of the SA-6300.

### For Recording

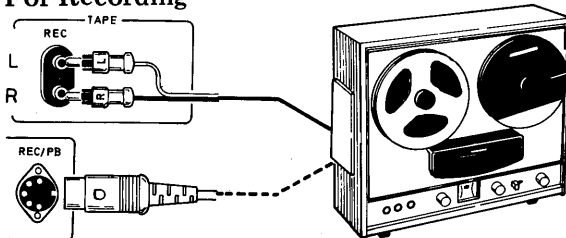

FUNCTION

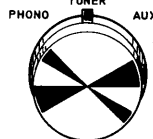

TAPE MONITOR



ON

- Set the FUNCTION switch to the program source to be recorded.
- With the TAPE MONITOR switch set to ON, the recording in progress may be monitored.

SA-6300

SA-6300

# CONDITIONS FREQUENTLY MISTAKEN FOR MALFUNCTION

In the event of a malfunction, first check the points indicated below. If this fails to correct the problem, contact a Pioneer Authorized Service Center. For further information, contact Pioneer Electronic Corp.

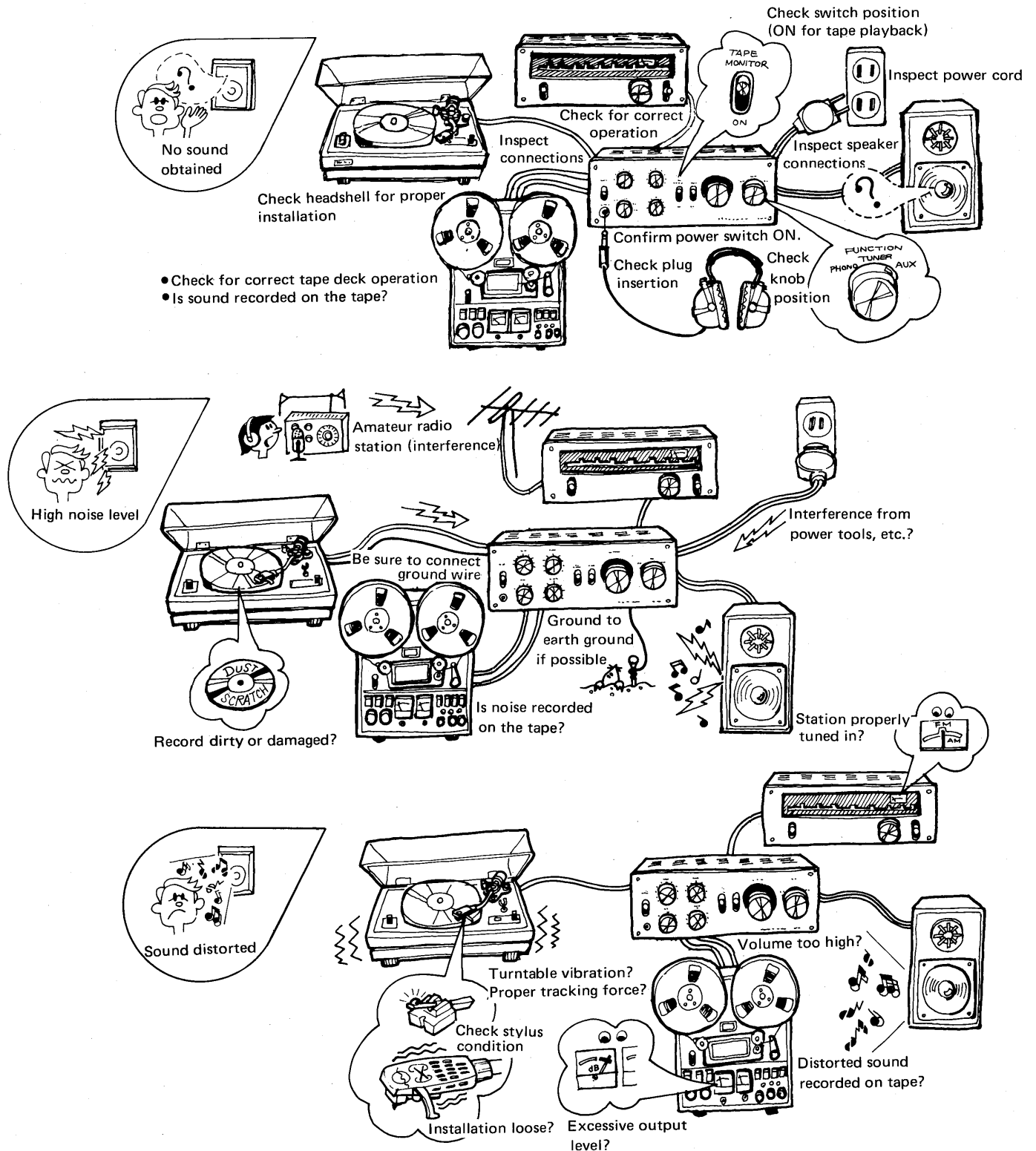

# SPECIFICATIONS

## Semiconductors

IC . . . . .	1
Transistors . . . . .	19
Diodes . . . . .	13

## Amplifier Section

### Continuous Power Output

40Hz ~ 20kHz	
(Both channels driven)	20W + 20W (8Ω, Rated power)
	20W + 20W (4Ω)
1kHz (Both channels driven)	22W + 22W (8Ω)
	24W + 24W (4Ω)

### Total Harmonic Distortion (40Hz ~ 20kHz)

(Continuous Rated Power Output)	No more than 0.8%
(1 W Power Output, 8Ω)	No more than 0.08%

### Intermodulation

(Continuous Rated Power Output)	No more than 0.8%
(1 W Power Output, 8Ω)	No more than 0.08%

### Power Bandwidth

(IHF, Both channels driven)	5Hz ~ 70kHz (T.H.D. 0.8%)
-----------------------------	---------------------------

### Output: Speaker

Headphone	Low impedance
-----------	---------------

### Damping Factor

(40Hz ~ 20kHz, 8Ω)	25
--------------------	----

### Input Sensitivity/Impedance

PHONO	2.5mV/50kΩ
TUNER	150m/50kΩ
AUX	150mV/50kΩ
TAPE PB	150mV/50kΩ
TAPE PB (DIN connector)	150mV/50kΩ

### PHONO Overload Level (T.H.D. 0.1%)

Output Level/Impedance	150mV
------------------------	-------

### Output Level/Impedance

TAPE REC	150mV
TAPE REC (DIN connector)	30mV/80kΩ

### Frequency Response

PHONO (RIAA equalization)	30Hz ~ 15kHz±0.5dB
TUNER, AUX, TAPE PB	20Hz ~ 30kHz±0.5dB

### Tone Control

BASS	+9dB, -8dB (100Hz)
TREBLE	+6dB, -6dB (10kHz)

### Loudness Contour (Volume control set at -40dB position)

	+8dB (100Hz), +5dB (10kHz)
--	----------------------------

### Hum & Noise (IHF, Short circuited, A Network)

PHONO	70dB
TUNER, AUX, TAPE PB	85dB

## Miscellaneous

Power Requirements . . . . .	AC 220V 50/60Hz
	or 110, 120, 130, 220 and 240V (switchable) 50/60Hz

Power Consumption . . . . .	<del>150W</del> 170W
	170W (Manufactured for England)

Dimensions . . . . .	350(W) x 125(H) x 282(D) mm
	13-3/4 x 4-15/16 x 11-1/8

Weight: Without Package . . . . .	6.9kg (14 lb 3 oz)
With Package . . . . .	7.7kg (16 lb 15 oz)

## Furnished Parts

Operating Instructions . . . . .	1
Connection Cord with Pin Plugs . . . . .	1
Fuse 3A . . . . .	1
Fuse 1.5A . . . . .	1 (5 line voltage model only)

**NOTE:**  
Specifications and the design subject to possible modification without notice due to improvements.

