

Speaker system

1. Tweeter
2. Woofer
3. Bass Reflex Duct
4. Speaker Wire

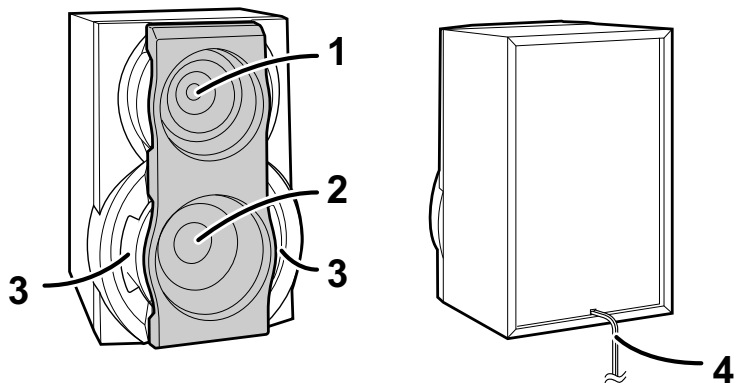

OPERATION MANUAL

Setting the Clock

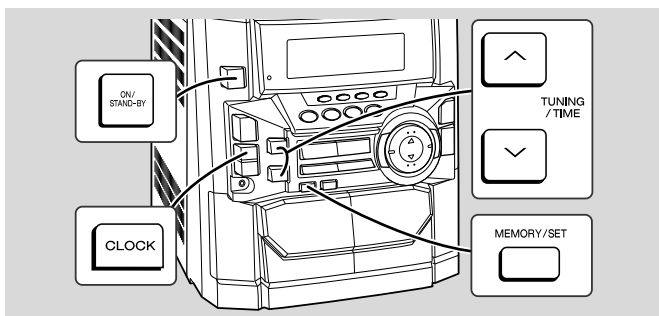

In this example, the clock is set for the 24-hour (0:00) display.

1 Press the ON/STAND-BY button to turn the power on.

2 Press the CLOCK button and within 5 seconds, press the MEMORY/SET button.



3 Press the TUNING/TIME (∨ or ∧) button to select 24-hour or 12-hour display and then press the MEMORY/SET button.



- | | | |
|------------|---|--|
| "0:00" | → | The 24-hour display will appear. (0:00 - 23:59) |
| "AM 12:00" | → | The 12-hour display will appear. (AM 12:00 - PM 11:59) |
| "AM 0:00" | → | The 12-hour display will appear. (AM 0:00 - PM 11:59) |

Note that this can only be set when the unit is first installed or it has been reset. (Refer to step 3 under "If trouble occurs")

4 Press the TUNING/TIME (∨ or ∧) button to adjust the hour and then press the MEMORY/SET button.



- Press the TUNING/TIME (∨ or ∧) button once to advance the time by 1 hour. Hold it down to advance continuously.
- When the 12-hour display is selected, "AM" will change automatically to "PM".

5 Press the TUNING/TIME (∨ or ∧) button to adjust the minutes and then press the MEMORY/SET button.



- Press the TUNING/TIME (∨ or ∧) button once to advance the time by 1 minute. Hold it down to change the time in 5-minute intervals.
- The hour will not advance even if minutes advance from "59" to "00".
- The clock begins counting from "0" seconds. (Seconds are not displayed.)
- The time display will disappear after a few seconds.

To confirm the time display:

Press the CLOCK button.
The time display will appear for about 5 seconds.

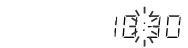

Note:

The "CLOCK" or time will flash at the push of the CLOCK button when the AC power supply is restored after a power failure or unplugging the unit. Readjust the clock as follows.

To readjust the clock:

Perform "Setting the Clock" from the beginning. If the time display is flashing, step 3 (for selecting the 24-hour or 12-hour display) will be skipped.

To change the 24-hour or 12-hour display:

- 1 Clear all the programmed contents. [Perform to step 3 under "If trouble occurs"]
- 2 Perform "Setting the Clock" from the beginning.

Troubleshooting Chart

Many potential "problems" can be resolved by the owner without calling a service technician. If something is wrong with this product, check the following before calling your authorized SHARP dealer or service centre.

General

Symptom	Possible cause
● The clock is not on time.	● Did a power failure occur? Reset the clock.
● When a button is pressed, the unit does not respond.	● Set this unit to the power stand-by mode and then turn it back on. ● If the unit still malfunctions, reset it. Refer to step 3 under "If trouble occurs"
● No sound is heard.	● Is the volume level set to "0"? ● Are the headphones connected? ● Are the speaker wires disconnected?

CD player

Symptom	Possible cause
● Playback does not start.	● Is the disc loaded upside down?
● Playback stops in the middle or is not performed properly.	● Does the disc satisfy the standards? ● Is the disc distorted or scratched?
● Playback sounds are skipped, or stopped in the middle of a track.	● Is the unit located near excessive vibrations? ● Is the disc very dirty? ● Has condensation formed inside the unit?

Tuner

Symptom	Possible cause
● Radio makes unusual noise consecutively.	● Is the unit placed near the TV or computer? ● Is the FM aerial or AM loop aerial placed properly? Move the AC power lead away from the aerial if located near.

Cassette deck

Symptom	Possible cause
● Cannot record.	● Is the erase-prevention tab removed?
● Cannot record tracks with proper sound quality.	● Is it a normal tape? (You cannot record on metal or CrO ₂ tape)
● Cannot erase completely.	
● Sound skipping.	● Is there any slack? ● Is the tape stretched?
● Cannot hear treble. ● Sound fluctuation.	● Are the capstans, pinch rollers, or heads dirty?
● Cannot remove the tape.	● If a power failure occurs during playback, the heads remain engaged with the tape. Do not open the compartment forcibly. Wait until electricity resumes.

Remote control

Symptom	Possible cause
● The remote control does not operate.	● Is the AC power lead of the unit plugged in? ● Is the battery polarity respected? ● Are the batteries dead? ● Is the distance or angle incorrect? ● Does the remote control sensor receive strong light?

Condensation

Sudden temperature changes, storage or operation in an extremely humid environment may cause condensation inside the cabinet (CD pickup, tape heads, etc.) or on the transmitter on the remote control.

Condensation can cause the unit to malfunction. If this happens, leave the power on with no disc (or cassette) in the unit until normal playback is possible (about 1 hour). Wipe off any condensation on the transmitter with a soft cloth before operating the unit.

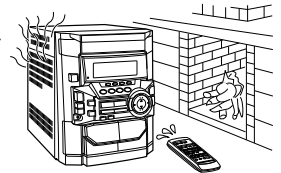

Troubleshooting Chart

If trouble occurs

When this product is subjected to strong external interference (mechanical shock, excessive static electricity, abnormal supply voltage due to lightning, etc.) or if it is operated incorrectly, it may malfunction.

If such a problem occurs, do the following

- 1 Set the unit to the stand-by mode and turn the power on again.
- 2 If the unit is not restored in step 1, unplug and plug in the unit, and then turn the power on.
- 3 If neither step 1 nor 2 restores the unit, do the following
 - ① Press the ON/STAND-BY button to enter the power stand-by mode.
 - ② Whilst pressing down the **▶/◀** button and the X-BASS/DEMO button, press the ON/STAND-BY button until "CLEAR AL" appears.



Caution:

This operation will erase all data stored in memory including clock, timer settings, tuner preset, and CD programme.

Before transporting the unit

- 1 Press the ON/STAND-BY button to turn the power on.
- 2 Press the CD button.
- 3 Press the **▲** OPEN/CLOSE button to open the disc tray. Remove all CDs inserted in the unit.
- 4 Press the **▲** OPEN/CLOSE button to close the disc tray. Make sure that "NO DISC" is displayed.
- 5 Press the ON/STAND-BY button to enter the stand-by mode, and then unplug the AC power lead from the AC socket.

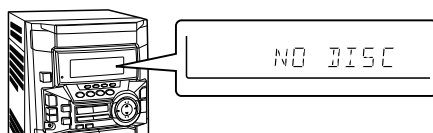

Remote Control

Test of the remote control

Face the remote control directly to the remote sensor on the unit.

The remote control can be used within the range shown below: Press the ON/STAND-BY button. Does the power turn on? Now, you can enjoy the music.

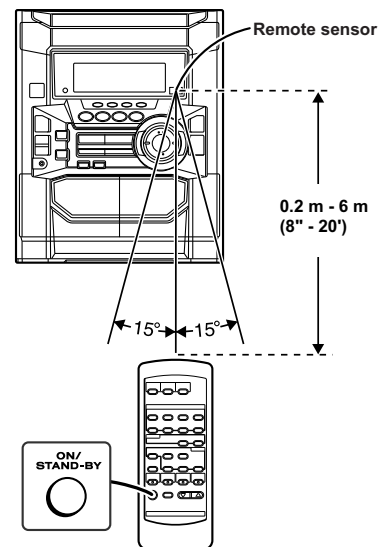

3 System connections

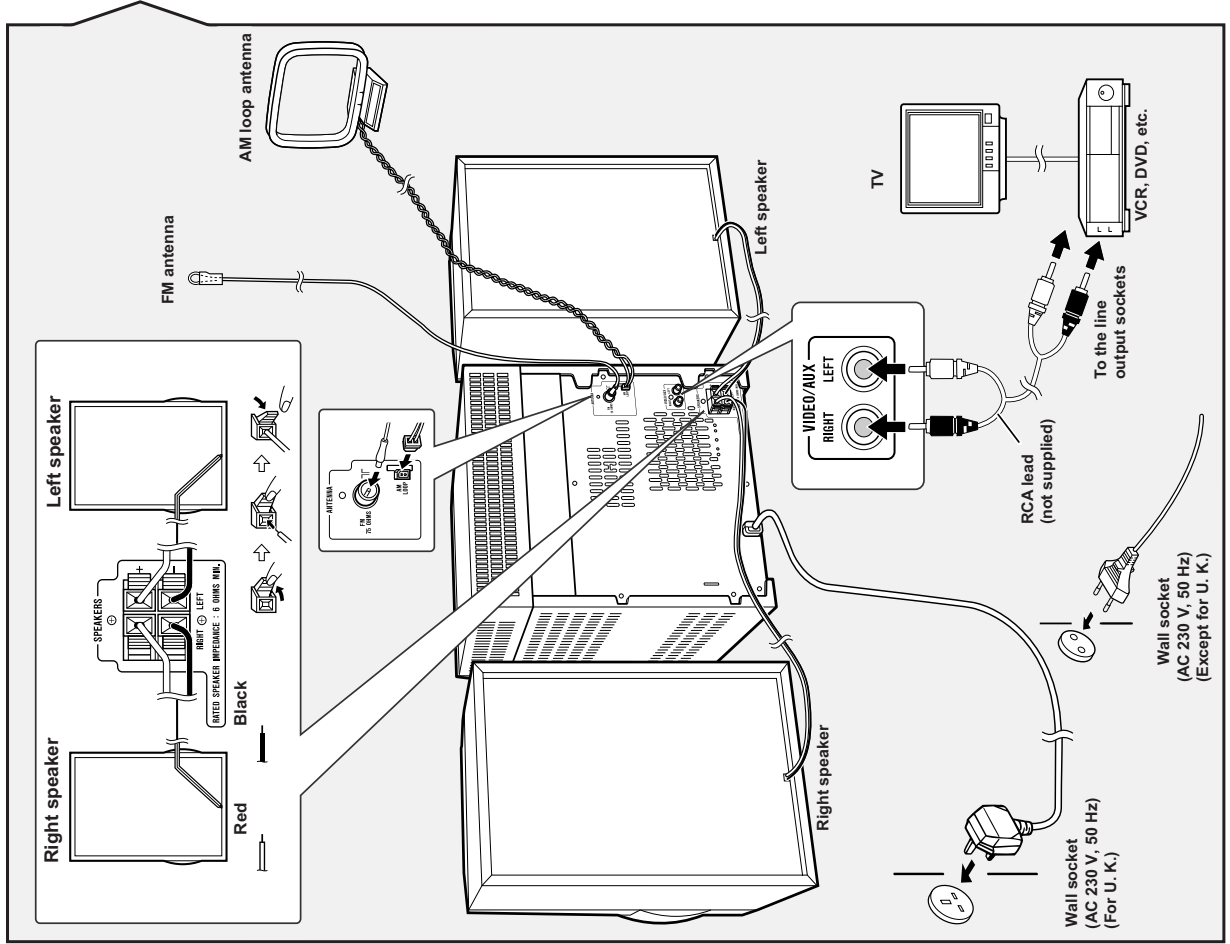

1 Accessories

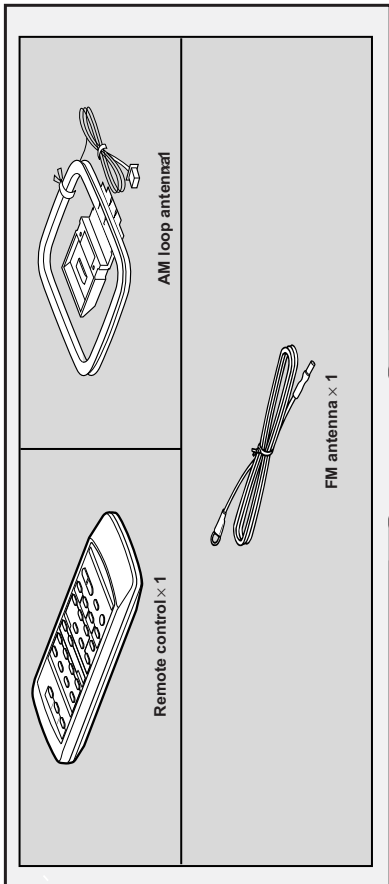

2 Battery installation of remote control

Use 2 "AA" size batteries (UM/SUM-3, R6, HP-7 or similar).

1 Remove the battery cover.



2 Insert the batteries as shown.

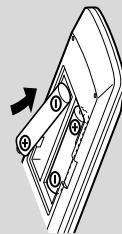

3 Replace the cover.



Batteries are not included.

4 Turn on your system

The first time the unit is plugged, the unit will enter the demonstration mode. You will see words scroll.

- 1 Press the X-BASS/DEMO button to cancel the demonstration mode.



- 2 Press the ON/STAND-BY button to turn the power on.

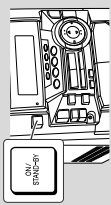

Listening to a CD (CDs)

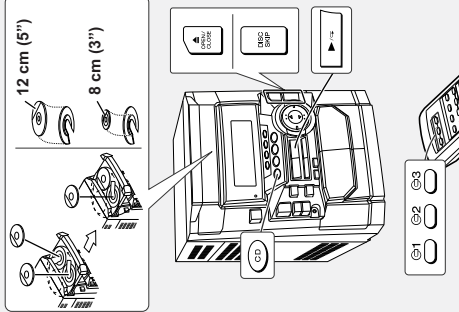

- 1 Press the CD button.
- 2 Press the OPEN/CLOSE button to open the disc tray.
- 3 Place the CD(s) on the disc tray, label side up. When loading a third disc, press the DISC SKIP button to turn the disc tray, then place the CD in the open position.
- 4 Press the OPEN/CLOSE button to close the disc tray.
- 5 To select the CD you want to listen to first, press one of 1 - 3 buttons on the remote control.
- 6 Press the PLAY button to start playback.

Listening to a cassette tape (TAPE 1 or TAPE 2)

- 1 Open the cassette door by pushing the area marked "PUSH EJECT".
- 2 Load a cassette into the TAPE 1 or TAPE 2 cassette compartment with the side to be played facing toward you.
- 3 Press the TAPE (1 → 2) button to select the cassette you want to listen to.
- 4 Press the PLAY button to start playback.

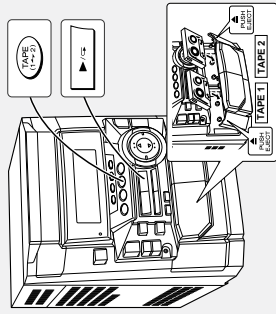

■ If trouble occurs

When this product is subjected to strong external interference (mechanical shock, excessive static electricity, abnormal supply voltage due to lightning, etc.) or if it is operated incorrectly, it may malfunction.

If such a problem occurs, do the following:

1. Set the unit to the stand-by mode and turn the power on again.
2. If the unit is not restored in step 1, unplug and plug in the unit, and then turn the power on.
3. If neither step 1 nor 2 restores the unit, do the following:
 - 1 Press the ON/STAND-BY button to enter the power stand-by mode.
 - 2 Whilst pressing down the PLAY button and the X-BASS/DEMO button, press the ON/STAND-BY button until "CLEAR AL" appears.

■ Maintenance

- Dirty heads, capstans or pinch rollers can cause poor sound and tape jams. Clean these parts with a cotton swab moistened with commercial head/pinch roller cleaner or isopropyl alcohol.
- When cleaning the heads, pinch rollers, etc., unplug the unit which contains high voltages.
- After long use, the deck's heads and capstans may become magnetised, causing poor sound. Demagnetise these parts once every 30 hours of playing/recording time by using a commercial tape head demagnetiser. Read the demagnetiser's instructions carefully before use.
- Clean the dust or stain on the CD pickup lens using a commercial cleaning disc (brush type).

Listening to the radio

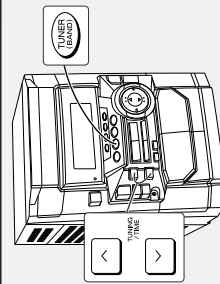

- 1 Press the TUNER (BAND) button repeatedly to select the desired frequency band (FM or AM).
- 2 Press the TUNING/TIME (V or ^) button to tune in to the desired station. When the TUNING/TIME button is pressed for more than 0.5 seconds, scanning will start automatically and the tuner will stop at the first receivable broadcast station.

To receive an FM stereo transmission Press the TUNER (BAND) button to display the "ST" indicator.

- "CD" will appear when an FM broadcast is in stereo.

FM stereo mode indicator

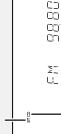

FM stereo receiving indicator

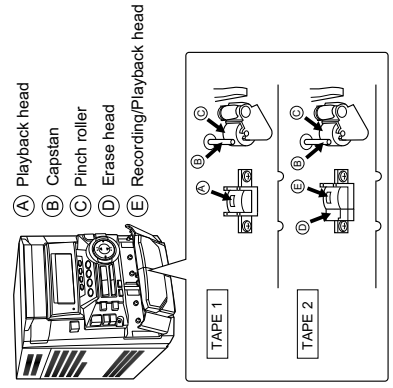
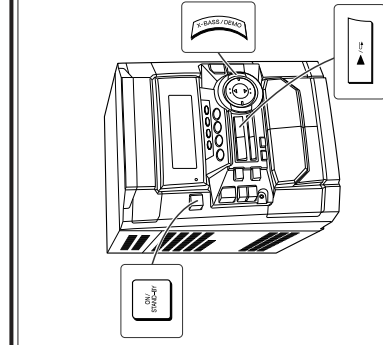

Using the Radio Data System (RDS)

RDS is a broadcasting service which a growing number of FM stations provide. These FM stations send additional signals along with their regular programme signals. They send their station names, and information about the type of programme such as sports or music, etc.

When tuned to an RDS station, "RDS" and the station name will be displayed. "TP" (Traffic Programme) will appear on the display when the received broadcast carries traffic information, and "TA" (Traffic Announcement) will appear whilst a traffic information is on air.

"EON" will appear whilst the EON (Enhanced Other Networks information) data is broadcast.

"PTYI" (Dynamic PTY Indicator) will appear whilst the Dynamic PTY station is received.

"RT" (Radio Text) will appear whilst the unit receives the Radio text data.

"CT" (Clock Time) will appear whilst the unit receives the RDS CT data.

You can control the RDS by using the buttons on the main unit only.

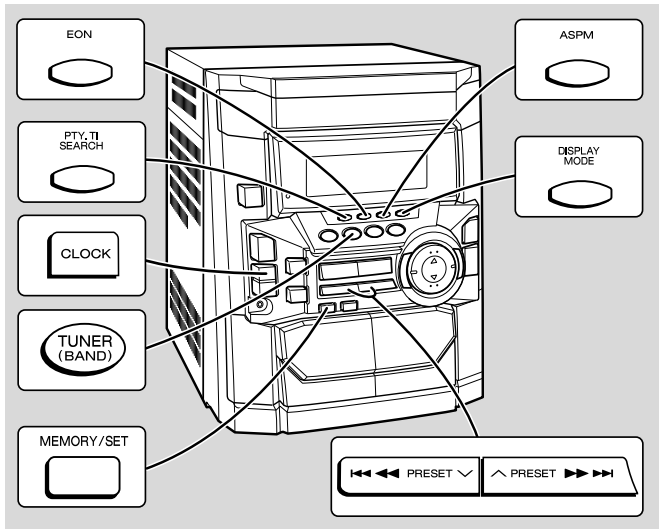

Information provided by RDS

Each time the DISPLAY MODE button is pressed, the display will switch as follows:

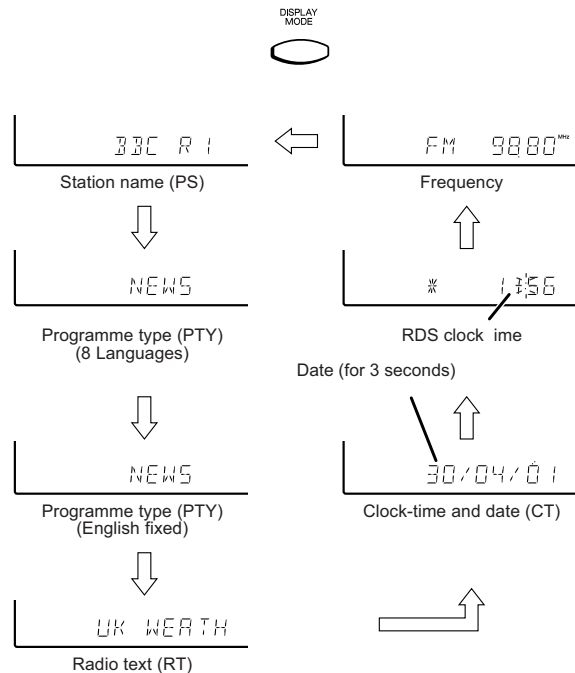

When you are tuning in to a station other than an RDS station or to an RDS station which sends weak signal, the display will change in the following order:

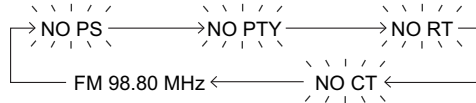

Descriptions of the PTY (Programme Type) codes, TP (Traffic Programme) and TA (Traffic Announcement).

You can search for and receive the following PTY, TP and TA signals.

NEWS	Short accounts of facts, events and publicly expressed views, reportage and actuality.
AFFAIRS	Topical programme expanding or enlarging upon the news, generally in different presentation style or concept, including debate, or analysis.
INFO	Programmes whose purpose is to impart advice in the widest sense.
SPORT	Programme concerned with any aspect of sport.
EDUCATE	Programme intended primarily to educate, of which the formal element is fundamental.
DRAMA	All radio plays and serials.
CULTURE	Programmes concerned with any aspect of national or regional culture, including language, theatre, etc.
SCIENCE	Programmes about the natural sciences and technology.
VARIED	Used for mainly speech-based programmes usually of light-entertainment nature, not covered by other categories. Examples include: quizzes, panel games, personality interviews.
POP M	Commercial music, which would generally be considered to be of current popular appeal, often featuring in current or recent record sales charts.
ROCK M	Contemporary modern music, usually written and performed by young musicians.
EASY M	Current contemporary music considered to be "easy-listening", as opposed to Pop, Rock or Classical, or one of the specialised music styles, Jazz, Folk or Country. Music in this category is often but not always, vocal, and usually of short duration.
LIGHT M	Classical music for general, rather than specialist appreciation. Examples of music in this category are instrumental music, and vocal or choral works.
CLASSICS	Performances of major orchestral works, symphonies, chamber music, etc., and including Grand Opera.
OTHER M	Musical styles not fitting into any of the other categories. Particularly used for specialist music of which Rhythm & Blues and Reggae are examples.
WEATHER	Weather reports and forecasts and meteorological information.
FINANCE	Stock Market reports, commerce, trading, etc.
CHILDREN	For programmes targeted at a young audience, primarily for entertainment and interest, rather than where the objective is to educate.

SOCIAL	Programmes about people and things that influence them individually or in groups. Includes: sociology, history, geography, psychology and society.
RELIGION	Any aspect of beliefs and faiths, involving a God or Gods, the nature of existence and ethics.
PHONE IN	Involving members of the public expressing their views either by phone or at a public forum.
TRAVEL	Features and programmes concerned with travel to near and far destinations, package tours and travel ideas and opportunities. Not for use for announcements about problems, delays, or roadworks affecting immediate travel where TP/TA should be used.
LEISURE	Programmes concerned with recreational activities in which the listener might participate. Examples include, Gardening, Fishing, Antique collecting, Cooking, Food & Wine, etc.
JAZZ	Polyphonic, syncopated music characterised by improvisation.
COUNTRY	Songs which originate from, or continue the musical tradition of the American Southern States. Characterised by a straightforward melody and narrative story line.
NATION M	Current Popular Music of the Nation or Region in that country's language, as opposed to International 'Pop' which is usually US or UK inspired and in English.
OLDIES	Music from the so-called "golden age" of popular music.
FOLK M	Music which has its roots in the musical culture of a particular nation, usually played on acoustic instruments. The narrative or story may be based on historical events or people.
DOCUMENT	Programme concerned with factual matters, presented in an investigative style.
TEST	Broadcast when testing emergency broadcast equipment or receivers.
ALARM !	Emergency announcement made under exceptional circumstances to give warning of events causing danger of a general nature.
NONE	No programme type (receive only).
TP	Broadcasts which carry traffic announcements.
TA	Traffic announcements are being broadcast.

Note: When you select a programme in the EON stand-by mode, the unit will display "TI" instead of "TA".