

SPECIFICATIONS S-7900A/S-8900A RECEIVER

AMPLIFIER:

POWER OUTPUT (IHF): 280 watts total.
POWER OUTPUT-RMS, both channels driven:
 90 watts X 2 @ 4 ohms, 1 KHz.
 65 watts X 2 @ 8 ohms, 1 KHz.
 60 watts X 2 @ 8 ohms, 20-20,000 Hz.
HARMONIC DISTORTION: 0.3% @ 8 ohm rated output, 0.10% @ 10 watts.
INTERMODULATION DISTORTION:
 0.3% @ 8 ohm rated output, 0.10% @ 10 watts.
STEREO & MONO SPEAKER OUTPUT IMPEDANCE: 4, 8, or 16 ohms.
STEREO HEADPHONE OUTPUT:
 High or low impedance.
STEREO RECORDING OUTPUT: 800 mv, 2K ohm.
POWER BANDWIDTH: 7-60 KHz 0.5% Dist.
FREQUENCY RESPONSE: Aux: 20-20 KHz \pm 1 db.
DAMPING FACTOR: 30:1 @ 8 ohms.
BASS CONTROL: \pm 13 db. @ 100 Hz.
TREBLE CONTROL: \pm 13 db @ 10 KHz.
INPUT SENSITIVITY (for rated output)
 Phono: 1.5 mv, 3.8 mv, 8.0 mv.
 Aux: 150 mv.
INPUT CAPABILITY FOR 1% dist.
 Phono: 100 mv.
 Aux: 2.5 V.
HUM AND NOISE:
 Phono: -65 db.
 Aux: -80 db.
 Vol. Control Min: -90 db.
CROSSTALK: -40 db @ 1 KHz.

TUNER (fm):

FM SENSITIVITY (IHF): 1.7 μ v.
 (-30 db noise & dist.).
SIGNAL-TO-NOISE RATIO: -70 db.
CAPTURE RATIO: 1.9 db.
SUPPRESSION OF AM: -60 db.
TUNING RANGE: 87.5 to 108.5 MHz.
DISTORTION: 0.15% @ 100% Mod. (Mono.).
SPURIOUS RESPONSE REJECTION: -95 db.

STABILITY: \pm 15 KHz (\pm .015%).
IMAGE REJECTION: -80 db.
IF REJECTION: -90 db.
ALTERNATE-CHANNEL SELECTIVITY: 65 db.
STEREO SEPARATION: 40 db @ 1 KHz.
FREQUENCY RESPONSE: Mono, 20-20 KHz \pm 1 db. Stereo, 20-15 KHz \pm 1 db.
ANTENNA: 300 ohm balanced or 75 ohm coax.
SPECIAL FEATURES:
 Four gang tuning capacitor.
 Solid-State Ceramic FM IF Filtering.
 FET rf and mixer stages.
 Hermetically-sealed Micro-circuit
 IF & Synchrophase FM Limiter/Detector.
 Flywheel-assisted velvet tuning.
 Dial scale 7/8 inches long, 0.2 MHz calibrations.
 Exclusive FET FM Inter-channel/side-band hush.
 Illuminated Zero-center tuning meter.
 Illuminated dial pointer.
 Noise-protected automatic FM stereo/mono switching @ 8 μ v.
 Triple-section AM tuner (S-7900A only).

TUNER (am):

SENSITIVITY: 4 μ v (30% mod. for 10 db S/N).
SELECTIVITY: 36 db (selectivity @ \pm 10 KHz).
FREQUENCY RESPONSE: 4.0 KHz (-6 db).
TUNING RANGE: 530 to 1625 KHz.
IMAGE REJECTION: -87 db @ 1 MHz.
IF REJECTION: -80 db @ 1 MHz.
ANTENNA: Ferrite Rod (rotatable),
 High Imp. Input.

GENERAL:

POWER REQUIREMENTS: 115-125 V, 50/60 Hz (Export models, 230 V) 30 to 300 watts fused.
AC OUTLETS: 100 W. switched.
SIZE: (overall): 16 1/4" W x 5 1/4" H x 14" D.
SHIPPING WEIGHT: 30 lbs.
OPTIONAL ACCESSORIES:
 Walnut-grained wood case (W-10)
 17 W x 14 D x 6 1/4 H.

Duplicates On Other Driver

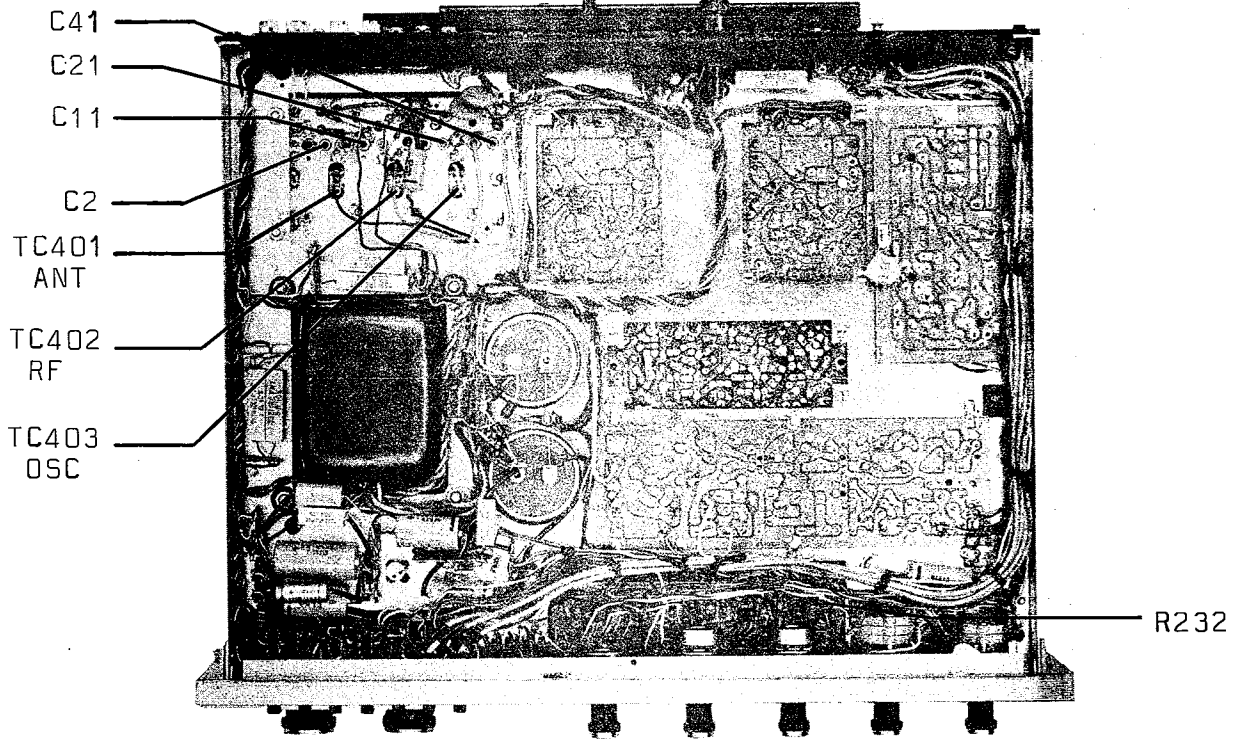
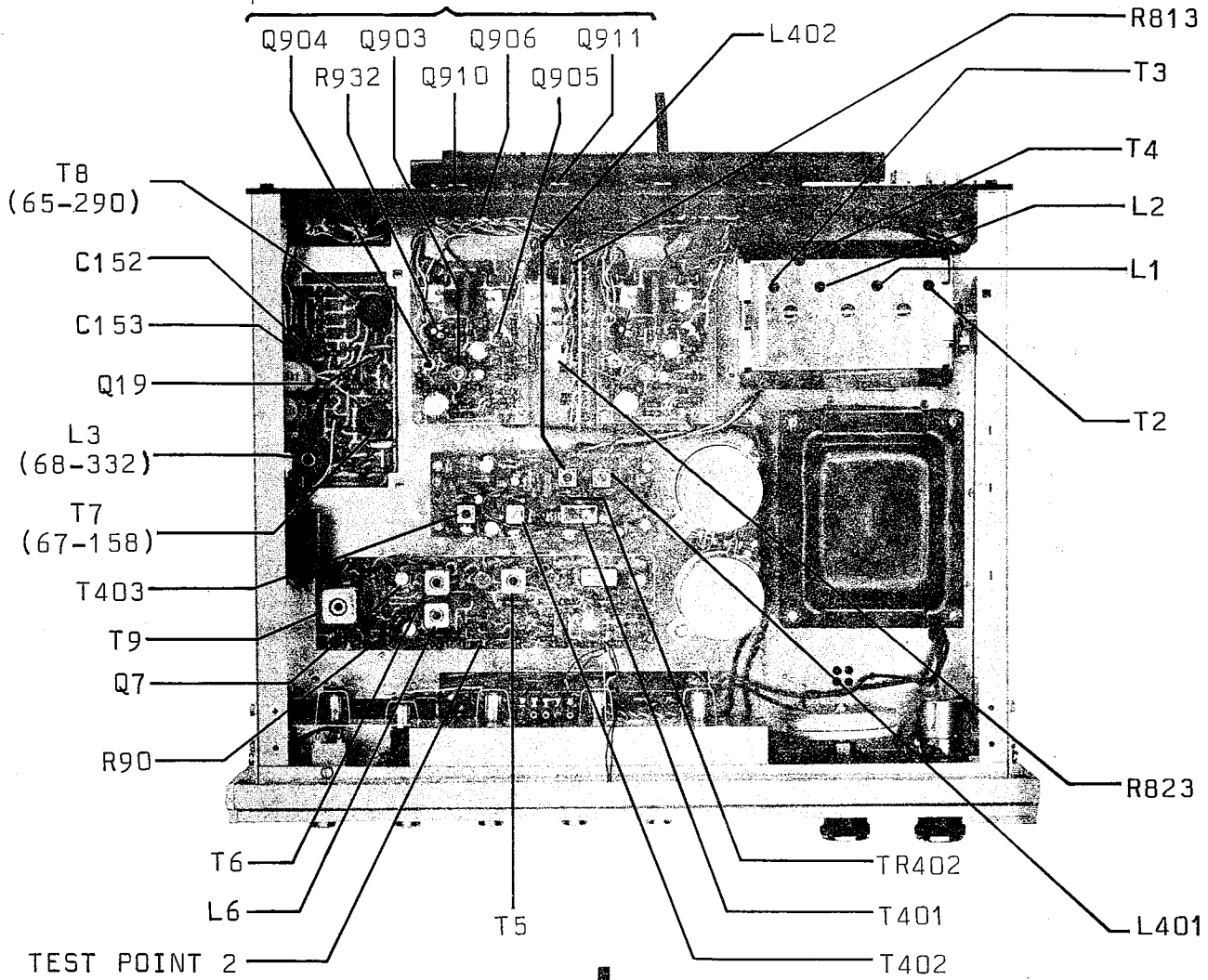

Figure 1

S-7900A/S-8900A TEST AND ALIGNMENT SECTION

NOTE: All references in the following material refers to Figure 1 unless otherwise indicated.

I. FM ALIGNMENT

1. Set the SELECTOR switch to "FM" and the FM muting switch off. Connect a FM Generator to the 300 ohm FM antenna terminals using a matching network if necessary as shown. (Figure 2)

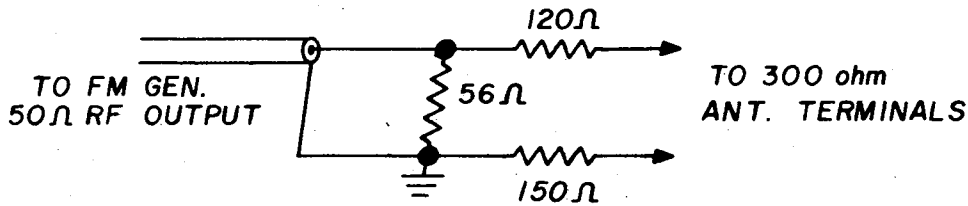

Figure 2

2. Tune the receiver to a point of no signal or interference near 90MHz.
3. Tune the FM Generator, modulated $\pm 300\text{KHz}$ @ approximately 20uv output level to the receiver frequency. Connect a RF detector probe to Pin 1, of CA3012 (Q7) and center the FM IF response on the oscilloscope. The FM IF bandpass characteristics are now being displayed. Adjust the transformer cores, both top and bottom of the RF converter (T4) and the 2nd and 3rd FM IF's (T5 & T6) for maximum gain and symmetry (see Figure 3).

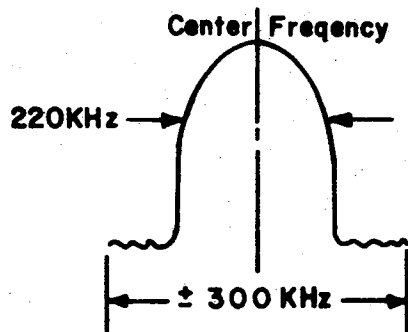

Figure 3

4. The FM front end alignment can also be determined while observing the oscilloscope display of Step 3. Tune the receiver and generator to a point of no interfering signal near 90MHz. Check that the receiver dial pointer indicates within $\pm 100\text{KHz}$ from the generator frequency. (If the generator output frequency is not accurately calibrated a FM station can be used as a calibration reference.) If

the dial deviation exceeds the above mentioned limit, adjust the local oscillator coil, (T3) slightly until optimum dial calibration is obtained. Next, adjust the coils of the RF amplifiers T2, L1 and L2, tuned circuits, for maximum gain. Tune the receiver and generator to a point of no interference near 106MHz. Check the dial calibration. If required, adjust the local oscillator trimmer (C41) until optimum dial calibration is obtained. Now, adjust the RF amplifier trimmers C2, C11 and C21 for maximum gain. Repeat alignment at 90MHz and 106MHz until no further improvement is obtained.

5. To align the FM Detector, with the FM generator connected as in Step 1, move the oscilloscope to the record output jack on rear panel. Reduce the modulation to ± 75 KHz and connect a DC VTVM to the detector output (4-channel adapter jack). Adjust the top core of the detector transformer (T9) for a zero indication on the DC VTVM and the bottom core of the detector transformer for maximum gain and linearity (see Figure 4).
6. A distortion analyzer should be used in conjunction with an oscilloscope to obtain the best linearity, using 400Hz, ± 75 KHz modulation. Fine adjust the bottom core of the detector transformer (T9) for lowest distortion (slight adjustment only).

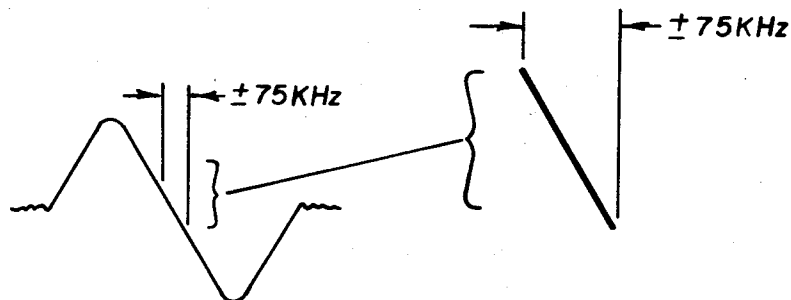

Figure 4

II. MUTING STEREO THRESHOLD ADJUSTMENT

1. This receiver is equipped with a muting circuit which automatically removes or reduces the noise (rushing sound) normally heard between broadcast channels on highly sensitive FM tuners. The noise threshold level in this electronic circuit can be adjusted with the muting threshold control, (R90) located on the FM IF board. Normal threshold level is approximately 5 micro volts.
2. To adjust muting sensitivity, connect the FM generator and oscilloscope as in Step 5 of FM Alignment. With the muting

switch in, slowly increase the generator output from zero to the automatic muting threshold level. Audio can now be observed on the oscilloscope. The desired threshold level can be set by adjusting R90 and repeating the above.

3. If when tuning through a station the hush/stereo threshold does not switch symmetrical, align L6 for symmetry while observing the oscilloscope with its probe at test point 2 (located on FM IF board).

III. MULTIPLEX ALIGNMENT

1. Set up the equipment as shown below (Figure 6) with the composite stereo generator set for pilot only. The scope/VTVM are connected to base of Q19. Before attempting multiplex alignment be certain that the FM I.F.'s have been properly aligned.

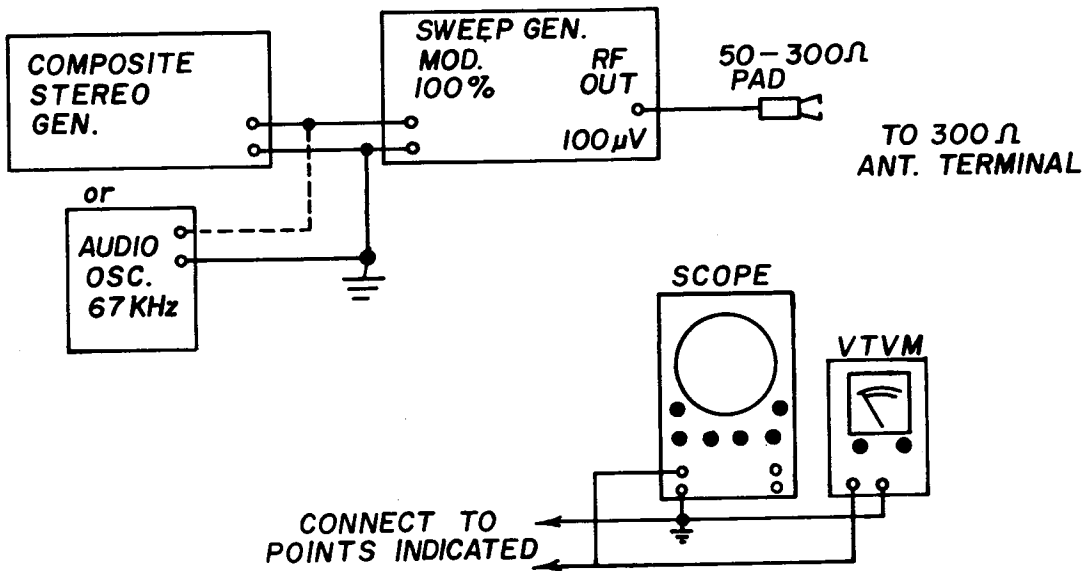

Figure 5

2. Tune the receiver to a point of no signal or interference near 90MHz and tune the sweep generator to this frequency.
3. Detune both cores of the 19KHz, double tuned transformer T7 (67-158), by rotating the cores outward. Tune the bottom core for maximum indication on the scope/VTVM. Now continue to rotate the core inward until the reading is -3db from maximum.
4. Tune the top core for maximum indication on the scope/VTVM (approximately 1.0V RMS, 19KHz).
5. Connect the scope/VTVM to Pin 1 of T8 (65-290) and tune the

- top and bottom cores for maximum indication. (approximately 1.5V RMS, 38KHz.)
6. Set the stereo generator for 67KHz, SCA Signal. Connect the scope/VTVM to Pin 2 of T8 (65-290). Adjust the 67KHz trap L3 (68-332) for a null.
 7. Set the composite multiplex generator for 400Hz, 100% Left channel only modulation. Check for approximately 0.5V RMS audio Left channel output across C152.
 8. Connect the scope/VTVM to the Right channel output across C153. Slightly re-adjust the bottom core of the 19KHz, double tuned transformer T7 (67-158) for best separation. Only slight adjustment is required. If not, repeat the previous steps or realign the tuner I.F.'s. The Right channel audio will be approximately -10db from the Left channel audio.
 9. Set composite generator for 19KHz pilot only. Check Left and Right outputs for 19KHz/38KHz residual output. It should be a minimum of -50db below audio reference.
 10. Move the Scope/VTVM to the Right channel RECORD output jack on the rear panel of the receiver. Adjust the Separation Adjust potentiometer R232 for a null. The separation should be 40db minimum in reference to 100% modulated audio. Alignment is now complete.

IV. AM ALIGNMENT

1. Set the receiver SELECTOR switch to "AM". Tune the receiver to a point of no signal or interference near 600KHz. Connect the scope/VTVM to the RECORD output jack. Connect the AM Generator output to the receiver AM antenna terminal through a 330 ohm resistor.
2. Adjust the AM Generator to 455KHz RF output, modulated 400Hz, 50%. Tune the AM converter (T401), 1st AM I.F., (T402), and the 2nd AM I.F. (T403) cores for maximum audio output.
3. Adjust the AM generator for 600KHz. If required, adjust the AM oscillator coil (L402), so that the generator signal is received by the receiver at 600KHz, as indicated on the dial glass. Adjust the rod antenna core (located at the end of the antenna rod assembly) and the RF amplifier (L401) output as indicated on the scope/VTVM.
4. Tune the receiver and generator to a point of no interfering signal near 1400KHz. Check the dial calibration and if necessary adjust the AM oscillator trimmer, (TC403) for optimum dial calibration. Adjust the antenna trimmer, (TC401) and RF amplifier trimmer (TC402) for maximum output.

5. Repeat Steps 3 and 4 until no further improvement is obtained.

V. AMPLIFIER SERVICING AND ADJUSTMENT

NOTE: To simplify the following descriptions only the left channel and its related circuitries are described. The right channel is identical except for reference symbol numbers. (see schematic diagram) All reference numbers refer to Figure 1 unless otherwise specified.

Preliminary checks of the dc voltages present at various points in your receiver can indicate whether a transistor is open, shorted, or functioning. Fault isolation in the pre-amplifier, tone amplifier, and driver stages can generally be isolated by checking the dc voltages or by comparing gain measurements at 1KHz as indicated on the schematic or by comparing the operating channel with the defective channel.

AMPLIFIER ELECTRONIC RELAY PROTECTION AND SPEAKER SYSTEM CHECKS:

This receiver incorporates a special electronic overload protection circuit which automatically disconnects the speakers when danger to the power amplifier exists or when danger to the speaker system exists. If there is no output to the speaker, check the speaker connections for shorted wires or shorted speakers. (Speaker load resistances should not indicate less than 4 ohm resistance on an ohmmeter).

The Electronic Relay Protection circuit consists of an electronic switch which senses two conditions, output current and DC center point voltage, to protect both the power amplifier and the speakers. The output current sensed through R934 and R925, power amplifier output transistor emitter resistors, is detected by Q801 and Q802 and its associated components. When the peak output current exceeds approximately 5 Amps, Q801 and Q802 conduct, causing the bi-stable multivibrator relay driver to deactivate the relay, disconnecting the speaker loads from the power amplifier.

The circuit can be returned to its original state by turning the receiver's power off and then waiting fifteen seconds before turning the receiver on again.

NOTE: If the receiver is turned off and on instantaneously the protection circuit will see a fault condition, so a minimum of fifteen seconds is required for complete resetting of this circuit.

While servicing the receiver it will be valuable to operate the receiver using a variable voltage power line (VARIAC) equipped with a line wattmeter to identify abnormal power consumption. Increase the power line voltage upward while observing the wattmeter. Power consumption should not exceed 10-20 watts (loudness control volume at minimum) as the voltage is increased to the rated 120 VAC. If the power consumption begins to exceed 20 watts, do NOT increase the power line voltage any further and determine whether the malfunction is in the power supply, tuner, or amplifier section.

If the power amplifier is suspected, verify the centerpoint voltage at the + speaker terminal for a ZERO voltage \pm 0.2V reading. If the centerpoint voltage reads high + voltage, suspect a shorted top side pre-driver transistor (Q904) or a shorted top side darlington output transistor (Q910) (schematic shows transistors as the top devices in each channel). If the center-point voltage reads minus, suspect a shorted bottom side pre-driver transistor (906) or a shorted bottom side darlington output transistor (Q911).

Remove both darlington output transistors from their sockets. Power consumption should drop considerably. Check the darlington output transistors for shorted junctions. Proceed by checking center point voltage. If center point voltage is not zero suspect faulty pre-driver transistors (Q904) and (Q906), bias transistor (Q905), differential amplifier (Q903), or associated components before replacing output.

If the fault still exists, then varify that capacitors are not shorted, circuit board contains no solder shorts, open resistors, poor solder connections, or broken pads.

If the center-point voltage reads zero voltage in accordance with the above check, apply audio signal to the channel or channels being tested and measure distortion. Distortion which exceeds amplifier ratings may be due to one of the following:

1. Output transistors are not matched beta.
2. Output bias requires readjustment.
3. Driver transistor has low beta.

The following performance indicates a properly operating amplifier with an 8 ohm resistive load.

Distortion at 2.0V

Less than 0.15% IM or Harmonic (1KHz), Typically 0.05%

Distortion at 10V

Typically 0.15% IM or Harmonic (1KHz)

Typically 60 Watts Dual Channel at 0.3% (20Hz-20KHz)

Typically 65 Watts Single Channel at 0.3%

OUTPUT TRANSISTOR BIAS:

Proper output transistor operation and output bias adjustment are most important to assure correct performance of the receiver. Bias adjustment is necessary if the output transistors are replaced,* or if any of the transistors in the driver circuitry, or the amplifier exhibits one or more of the following symptoms:

1. Overheating of the output transistors under normal operating conditions.
2. Excessive low level Intermodulation or Harmonic Distortion - more than 0.10% at 2.0 volts across 8 ohms.

*It is extremely important that the mica insulating washers used to separate the output transistors from their heat sinks be unbroken and installed properly with silicon grease liberally applied to all surfaces in contact with each other. Make certain the emitter and base pins of the output transistors do not contact any part of the heat sinks.

SUGGESTED AMPLIFIER TEST BENCH SET-UP

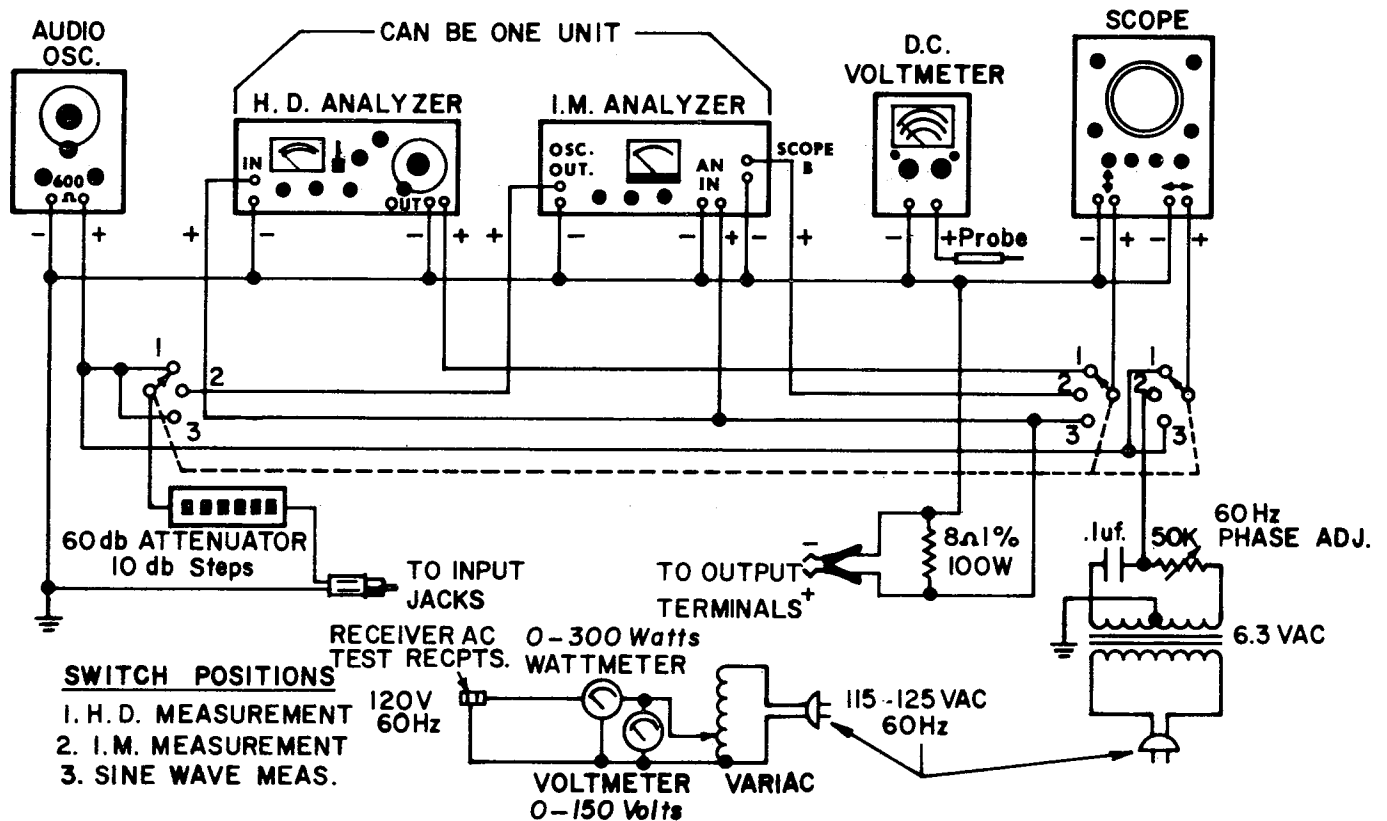
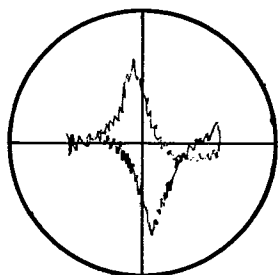

Figure 6

OUTPUT AND BIAS ADJUSTMENT USING AN INTERMODULATION DISTORTION ANALYZER

1. Connect the receiver for testing similar to Figure 6.
2. Connect an Intermodulation Distortion Analyzer with a ratio of 4:1 using 60Hz and 7000Hz to the receiver (AUX) input and set the selector switch to AUX.
3. Set the volume control to maximum and adjust the generator for a receiver output of 2.0 volts across 8 ohms.
4. While observing the resultant distortion waveform, adjust the bias potentiometer (R932) so that the crossover distortion is at a point of being eliminated. (Class "AB")
 Note: Class "A" operation (continued CW rotation) causes output transistors to overheat and draw excessive current.

REFER TO DIAGRAMS BELOW



Improper Bias Adjustment

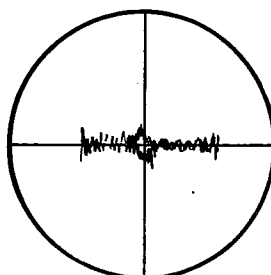

Proper Bias Adjustment

5. Repeat Steps 3 to 4 for the opposite channel.

The following performance indicates a properly operating amplifier with an 8 ohm load.

Less than 0.15% IM Distortion at 2.0V
Typically 0.15% IM Distortion at 10V
65 Watts of power per channel at clipping

If an Intermodulation Distortion analyzer is not available an oscillator and a Harmonic Distortion analyzer may be used for adjustment of the output transistor bias as follows:

1. Connect the receiver for testing similar to Figure 6.
2. Connect an oscillator with less than .05% distortion at 1KHz to the receiver (AUX) input and set the selector switch to AUX.
3. Set the volume control to maximum and adjust the oscillator for a receiver output of 2.0 volts across 8 ohms.
4. Using the Harmonic Distortion Analyzer looking at the distortion of the receiver output, properly nulled, make the adjustment as follows: Adjust the bias for Class "AB" operation by turning the bias potentiometer (R932) so that the crossover is at a point of being eliminated. Note: Class "A" operation (continued CW operation) causes the output transistors to draw excessive current and overheat. Refer to diagrams below:

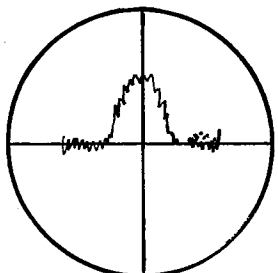

Improper Bias Adjustment

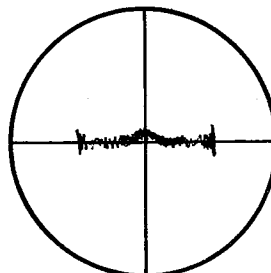

Proper Bias Adjustment

5. Repeat Steps 3 to 4 for the opposite channel.

The following performance indicates a properly operating amplifier with an 8 ohm load @ 1KHz.

Less than 0.15% THD at 2.0V (typically 0.05%)
Typically 0.15% THD at 10V
60 Watts dual channel @ 0.3% (20Hz - 20KHz)
65 Watts of power per channel at clipping

Bias can also be adjusted by using a VARIC equipped with a line wattmeter:

1. Turn the loudness control to minimum.
2. Adjust the bias potentiometers (R932), to the point at which the receiver begins to cause a very slight increase in line wattage consumption.

PROTECTION BOARD ADJUSTMENT:

1. Connect the receiver for testing similar to Figure 6 with 4 ohm loads on both channels.
2. Connect an oscillator with less than .05% distortion at 1KHz to the receiver (AUX) input and set the selector switch to AUX.
3. Set the volume control to maximum and adjust the oscillator for a receiver output of 19V across 4 ohms, both channels and adjust R813 (Protection Adj.) until relay deactivates.
4. Turn unit off. Wait fifteen seconds and recheck.

FOUR-CHANNEL OPERATION

The S-8900A/S-7900A incorporates a four-channel matrixing circuit. This simple matrixing circuit allows recorded ambient signals which are not reproduced during conventional stereo playback to be converted to four-channel sound without additional amplifying equipment. By connecting two additional speaker systems, one each to the REMOTE Left and Right terminals, they then become the left rear and right rear sound sources when the rear panel slide switch is in the Dynaquad position. In the Dynaquad OUT position the speakers connected to the remote terminals can be utilized as a second set of stereo sound sources in the same area or at a remote location.

PUSH BUTTON SWITCH REPAIR PROCEDURE

To repair a defective section of the push button assembly proceed as follows:

I. Disassembly of Buttons

1. Depress and lock buttons (A) 1, 2, 3, 5 & 6 (depress completely to lock).
2. Then depress button #4 approximately 3/16" and maintain.
3. With a long nose pliers grasp the flange of the latch bar clip (D). (right side of switch)
4. Pull the clip forward enough to clear the Latch Bar tab (F) (left side of switch) and slide the latch bar clip as far to the right as possible and then release it.
5. Then slide the Latch Bar (F) to the left and slowly release the tension on push button #4.
6. Each button may now be removed by depressing and then releasing the button slowly.

II. Repairing

1. Locate the malfunction and repair the defect by referring to the push button detail for disassembly and reassembly of various sections.

III. Reassembly of buttons

1. Depress and lock buttons 1, 2, 3, 5 & 6.
2. Slide the latch bar (F) to the left, replace Latch Bar Clip (D) and insert button #4 depressing it about 1/4".
3. With a small screwdriver slide the tab on the Latch Bar (F) (left side of button) as far as possible to the right.
4. Slowly release push button #4 to its normal position.
5. With a long nose pliers grasp the Latch Bar Clip (D), pulling it forward enough to clear the small tab on the Latch Bar (F) (left side of button) sliding the Latch Bar Clip (D) to the left until the small tab is visible through the hole in the latch bar clip (D).
6. Slowly allow Latch Bar Clip (D) to return to a flush position against the Frame (E), making sure the small tab is encompassed by the Latch Bar Clip (D).
7. All push buttons are now locked and can be returned to their normal position.

NOTE: If push button #4 binds, the pin on the right hand side of the Latch Bar Clip (D) has been caught by the spring.

PUSH BUTTON DETAIL

- A - Push Button
- B - Spring Contact (pair)
- C - Spring
- D - Latch Bar Clip
- E - Frame
- F - Latch Bar
- G - Switch Body
- H - Locking Pin
- J - Locking Pin Spring
- K - Locking Pin Spring Retainer

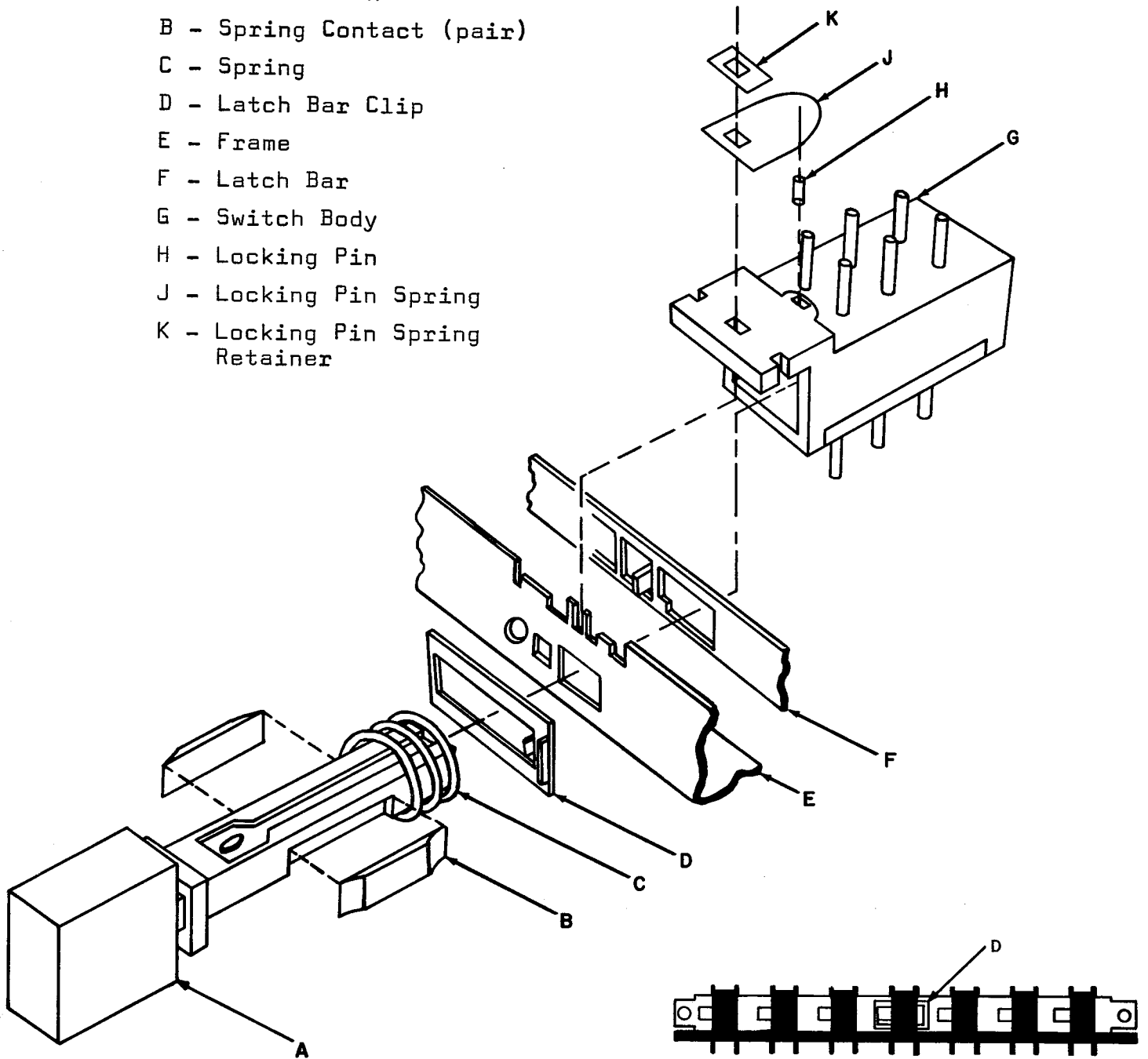

MODEL S-7900A & S-8900A
STEREO RECEIVER
SERVICE MANUAL
ADDENDUM #1

The amplifier protection board adjustments, on page 12, in the S-7900A/S-8900A Service Manual pertain to Serial Nos. 7R215000-7R216049/8227000-8228549 only.

Subsequent production used a more elaborate protection system. It is imperative, in the design of a high power amplifier, to include appropriate techniques to provide protection for both the amplifier and speaker load. The primary purpose of the relay protection circuit is to disconnect the load, if a potentially damaging situation exists.

The complementary darlington output transistors are load line limited, with the maximum current limited to 7A peak (equivalent to 100W @ 4 ohms). Signal voltages forward bias transistors, Q801 & Q802 (left channel), shunting the output transistors base drive signal.

The dual comparator, integrated circuit, IC801, and associated sensing circuit is a bridge system which in effect measures the speaker line impedance. The comparator (left channel) Pins, 5 & 6, are prebiased so that Pin 5 is 0.6V positive with respect to Pin 6. With this condition, the comparator output is high (28.6V), hence the bi-stable multivibrator transistors, Q805 & Q806, activate the relay, connecting the speaker loads to the amplifier. In this process the AC PWR. turn-on, speaker pops are also eliminated.

As the load impedance is reduced, a point is reached with signal drive, where, the rectified signal drives Pin 6 positive in respect to Pin 5. At this point the comparator output switches low (1V), causing the bi-stable relay driver to deactivate the relay, disconnecting the potentially dangerous load condition.

This circuit achieves variable current limiting, hence power limiting, as an inverse function of the amplifier load. The relay control circuits are separately triggered by each channel, but both shut down simultaneously. For example, power output is typically limited to 100 watts @ 4 ohms, 90 watts @ 3 ohms, 40 watts @ 2 ohms, 5 watts @ 1 ohm. Normally, in a 1 ohm load condition, with current limiting only (without the, patent applied for, variable current limiting system), the output transistors would be required to dissipate 300 watts, which would result in their instantaneous destruction.

PROPER OPERATION:

Test each channel separately with a 2 ohm load. A 1KHz signal (AUX. input) should deactivate the relay and disconnect the load @ 10V \pm 2V output.

WARNING:

If relay fails to disconnect the load by 12V output, do not further increase the drive. Isolate the defect, repair and repeat the test.

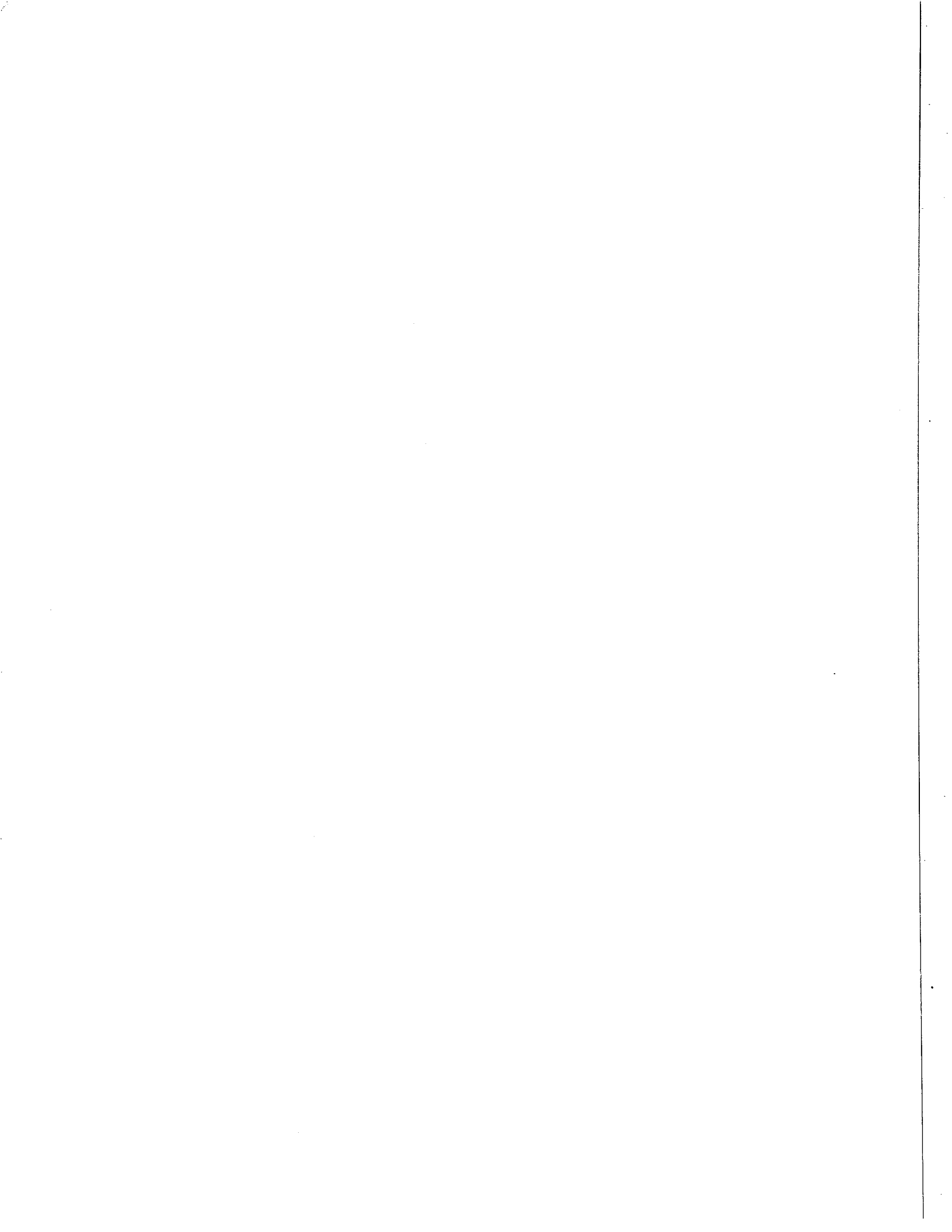

S-7900A & S-8900A PARTS LIST

PART DESCRIPTION	SCHEMATIC REFERENCE NO.	PART NO.	LIST* PRICE
<u>TRANSISTORS</u>			
AUDIO, LOW SIGNAL	Q13,204,304,501,502,503, 504,805,806,901a,901b	S169/BC169	.63
AUDIO, LOW SIGNAL, GRN. DOT	Q201,202,203,301,302,303	S169N/BC169N	.78
AUDIO, LOW SIGNAL (NPN)	Q18,20,21	SPS41	.81
AUDIO, (NPN)	Q801,803	MPS-A20	.36
AUDIO, (NPN)	Q906a,906b	S636/SPS2197	1.76
AUDIO, (PNP)	Q802,804	MPS-A70	.40
AUDIO, (PNP)	Q11,12,19,902a,902b	SPS2196	.72
AUDIO, (PNP)	Q904a,904b	S637/SPS2198	2.03
AUDIO, DUAL (NPN)	Q903b,903b	SPS5556/MD8003	1.78
IF (NPN)	Q8	SPS4345	.84
IF (NPN)	Q9	SPS868	.99
POWER SUPPLY, (NPN)	Q14	37649	1.80
POWER SUPPLY, BIAS (NPN)	Q15,905,914	SJE667	1.13
RF, AM (NPN) 25C535A	TR401	30200081	1.54
RF (NPN)	Q3	2N5208/MPS6580	.99
IF, AM (NPN) 25C930E	TR402,404	30200272	.82
IF, AM (NPN) 25C711F	TR403	30200362	.71
OUTPUT (NPN)	Q910,912	SJ1902	6.80
OUTPUT (PNP)	Q911,913	SJ1903	8.10
MOS FET	Q1	60693	3.33
MOS FET	Q2	60692	3.33
<u>DIODES</u>			
1N34A	D401,402	30600020	.40
RECTIFIER, SILICON	X1,808,809,811	A692T5-0	.48
RECTIFIER, SILICON	X2,3,4,5	A692X19	1.00
SILICON	X6,7,8,14,15,16,17,18,19, 801,802,803,804,805,806, 807,810	B692X13-4	.65
SILICON	Z902a,902b	A693X2/MZ2361	.50
ZENER, SILICON, 13V, 5%	Z1	A694X1-0A	1.00
ZENER, SILICON, 27V, 10%	Z2	A694X4-0	1.70
ZENER, SILICON, 10V, 5%	Z901a,901b	A694X3-0	.54
<u>INTEGRATED CIRCUITS</u>			
MICROCIRCUIT	Q4,5,6,10	LM703	1.04
MICROCIRCUIT	Q7	CA3012	3.51
MICROCIRCUIT, DUAL OP AMP.	IC801	RC4558DN/MC1458P	2.60
<u>CAPACITORS, ELECTROLYTIC</u>			
4.7 uf @ 25V	C422	64043475	.48
10 uf @ 10V	C402	64041106	.32
10 uf @ 16V	C420	64042106	.48
10 uf @ 25V	C419	64043106	.48
10 uf @ 35V	C820,910a,910b	B120X44-3	.38
33 uf @ 10V	C423	64041336	.48
47 uf @ 16V	C415	64042476	.56
47 uf @ 35V	C921a,921b	B120X42-3	.38
50 uf @ 35V (AXIAL)	C184,185	B120X21-2	.46

PART DESCRIPTION	SCHEMATIC REFERENCE NO.	PART NO.	LIST* PRICE
<u>CAPACITORS, ELECTROLYTIC (CONT.)</u>			
100 uf @ 10V	C200,203,300,303	B120X37-3	.29
100 uf @ 16V (AXIAL)	C17	B120X26-2	.49
220 uf @ 16V	C53	B120X38-3	.72
220 uf @ 35V	C901a,901b	B120X43-3	.51
220 uf @ 35V (AXIAL)	C173,175,176,183	B120X33-2	.51
250 uf @ 16V (AXIAL)	C174	B120X74-2	.51
500 uf @ 50V (AXIAL)	C172	B120X30-2	1.66
7000 uf @ 50V	C182,186	A120R18-0	6.39
<u>CAPACITORS, TANTALUM</u>			
.22 uf @ 35V	C250,350,411,501,502,503,CTAD3224M1 504		.46
1 uf @ 35V	C102,103,211,311,505, 900a,900b	CTAD3105X1	.43
10 uf @ 35V	C110,130,141,233,241,242,CTCD3106X1 244,333,341,342,344,506, 507		.63
<u>COILS AND TRANSFORMERS</u>			
COIL, FM INTERSTAGE	L1	154190	.54
COIL, FM INTERSTAGE	L2	154407	.41
COIL, 67 KHz	L3	68-332C	1.62
COIL, RF CHOKE (10 uh)	L4,5	A150R3	.21
COIL, FM BANDWIDTH DETECTOR	L6	72-152	2.90
COIL, 10.7MHz TRAP	L7	154303	.45
COIL, AM RF	L401	35504056	.84
COIL, AM OSC CHOKE	L402	35501052	.84
COIL, RF CHOKE (100 uh)	L403,L404,L405,L406	35500020	.43
COIL, AM ROD ANTENNA		B1100R10	6.50
TRANSFORMER, FM RF	T2	154185	.41
TRANSFORMER, FM RF	T3	154298	.45
TRANSFORMER, AM CONVERTER CFV60A	T4	153148	.72
TRANSFORMER, FM IF	T5,6	72-140	3.10
TRANSFORMER, 19 KHz	T7	67-158B	2.75
TRANSFORMER, 38 KHz	T8	65-290B	3.02
TRANSFORMER, FM DETECTOR	T9	72-138	5.70
TRANSFORMER, AM (CFV60A)	T401	35700003	1.38
TRANSFORMER, AM IF (403B)	T402	35704032	.84
TRANSFORMER, AM IF (402D)	T403	35704024	.84
TRANSFORMER, POWER (DOMESTIC)	T1	B922R8-3A	24.70
TRANSFORMER, POWER (EXPORT)	T1	2B922R8-3A	33.24
<u>VARIABLE RESISTORS</u>			
BIAS ADJUST (1K)	R932a,932b	A675X2-0	.41
HUSH THRESHOLD (2.5K)	R90	A675T3-0A	.45
STEREO SEPARATION (10K)	R232	A675X3-0	.41
AM LEVEL (10K)	VR401	28100035	.78
METER ADJUST (20K)	VR402	28100008	.78
PROTECTION ADJUST (25K)	R813	A675T8-1	.50
LOUDNESS CONTROL W/SWITCH (50K)	R257a, 257b	A671R7-1	1.26

LIST*
PRICE

PART DESCRIPTION	SCHEMATIC REFERENCE NO.	PART NO.	PRICE
<u>VARIABLE RESISTORS (CONT.)</u>			
BALANCE CONTROL (100K)	R250	A670R36-0	1.28
TONE CONTROLS, DUAL (100K)	R235a,235b,241a,241b	A670R37-0	2.05
<u>GENERAL SECTION</u>			
INSULATOR, MICA (T0-3)		A021F1-0	.05
BEAD, FERRITE		21B235/NQ40R1	.10
FM ANTENNA		B105R2-2	1.52
FILTER, BANDPASS		B162R3-1	3.38
FILTER, LOW-PASS	LPF1	A162R4-0	4.85
FUSE, 4 AMP 3 AG	F1	312004	.23
METER, TUNING (ZERO-CENTER)		B550R8-0	5.72
PILOT LIGHT #53		630B53	.20
PILOT LIGHT #756		630B756	.47
RELAY D.P.D.T.	RL1	A700R1-0	9.70
THERMOSTAT		A701R1-1	2.15
SWITCH, ROTARY SELECTOR (3 POS.)	S1	A860R25-0	5.45
SWITCH, ROTARY SELECTOR (4 POS.)	S1	A860R26-0	5.55
SWITCH, ROTARY MODE (5 POS.)	S2	A860R22-0	4.07
SWITCH, SLIDE D.P.T.T.	S4	A864R1-3	.64
SWITCH, SLIDE MINIATURE	S12	A864R5-1	.72
SWITCH, PUSH BUTTON ASSY.	S5,6,7,8,9,10,11	B866R6-1	8.30
<u>MECHANICAL SECTION</u>			
DIAL POINTER ASSY.		A201R9-0	2.80
KNOB, SMALL		A469X3-0	1.45
KNOB, LARGE W/MARK		A469X1-0	1.30
KNOB, LARGE W/O MARK		A469X2-0	1.22
DIAL GLASS, VINYL (FM)		F642R8-0	1.82
DIAL GLASS, VINYL (AM-FM)		F642R10-0	1.82
DARK PANEL, PLEXIGLAS		C642R9-0	2.40
FEET, POLYSTYRENE		A645X1-0	.40
SOCKET, I.C. (14 PIN)		A790R2-0	.45
SOCKET, OUTPUT TRANSISTORS		A790T7-1	.38
SOCKET, DRIVER TRANSISTORS		A790T10-0	.14
JACK, HEADPHONES		A795R4-0	.83
FUSE POST		A796X2-1A	1.04
SOCKET, STEREO LIGHT		A798R15-0	.22
SOCKET, PILOT LIGHT		A798S1-0A	.21
CARTON, SHIPPING		B130R50-2	3.60
WOOD CABINET		E1200R13-1	24.95

*Note: Price subject to change without notice.

S-7900A/S-8900A DIAL STRINGING DETAIL

START WITH GANG CLOSED (DRIVE PULLEY ROTATED CCW). HOOK EYELET END OF STRING AT POINT (1) AND PROCEED TO TOP INSIDE EDGE OF DRIVE PULLEY. FOLLOW POINTS (2) THRU (10). FROM POINT (10) CONTINUE TO OUTSIDE EDGE OF DRIVE PULLEY AND WRAP 1 1/2 TURNS CCW AROUND PULLEY BEFORE HOOKING SPRING AT POINT (11).

