

SCHEMATIC DIAGRAMS

回路図

CONTENTS 目次

CONTROL	2
FADER(1/3)	3
FADER(2/3)	4
FADER(3/3)	5
INLET & TRANSPORT & SYNC	6
INPUT	7
MAIN (1/11) (CPU)	8
MAIN (2/11) (1394 LINK)	9
MAIN (3/11) (1394PHY)	10
MAIN (4/11) (FPGA)	11
MAIN (5/11) (CLOCK)	12
MAIN (6/11) (ANALOG 1/2)	13
MAIN (7/11) (ANALOG 3/4)	14
MAIN (8/11) (ANALOG 5/6)	15
MAIN (9/11) (ANALOG 7/8)	16
MAIN (10/11) (PHONE)	17
MAIN (11/11) (POWER & ETC)	18
MIC (1/2)	19
MIC (2/2)	20
MIDI & PHONE	21
MODE	22
OUTPUT	23
POWER	24
SELECT	25
WIRING	26

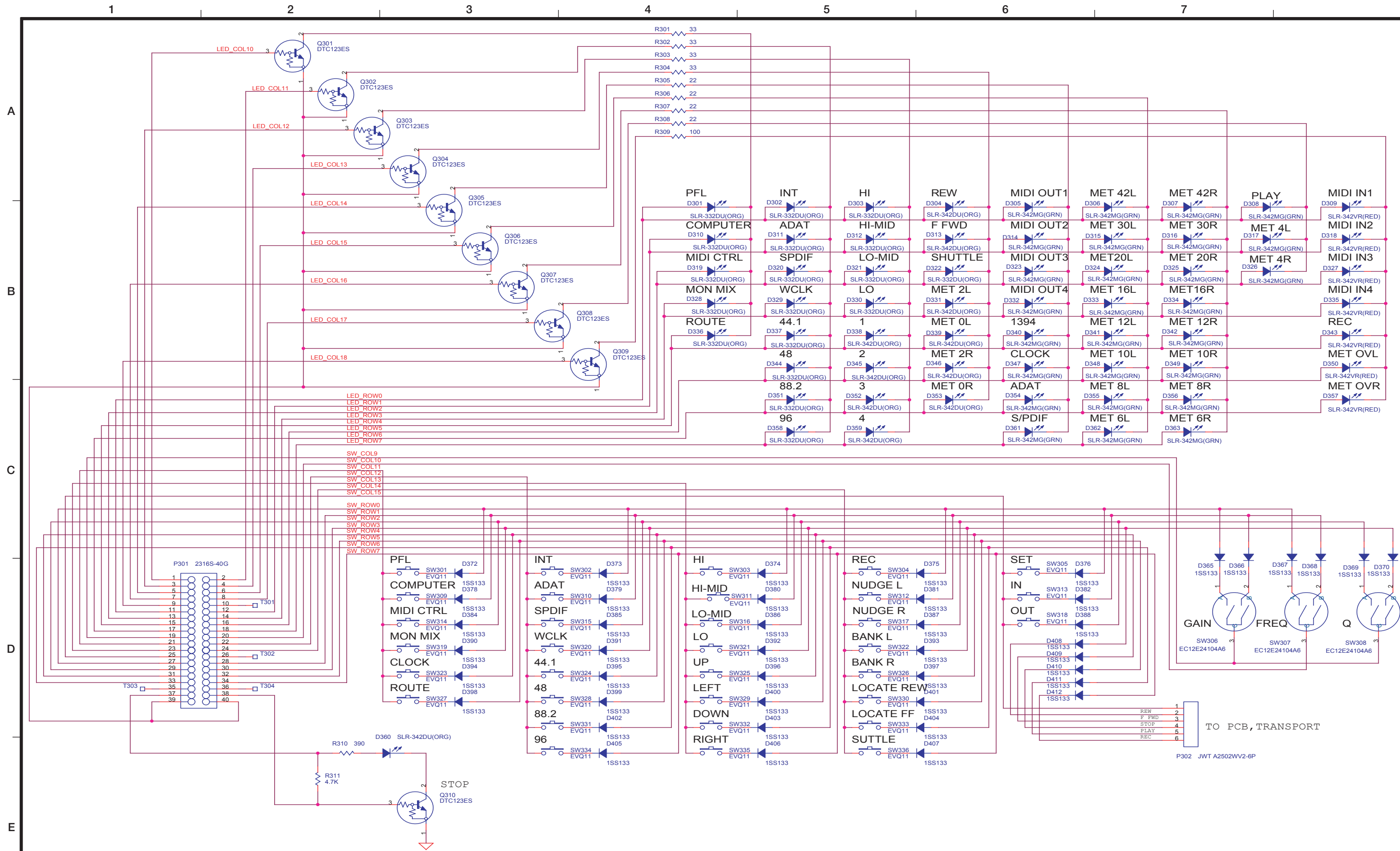

Professional Control Surface/FireWire Audio-MIDI Interface **FW-1884**

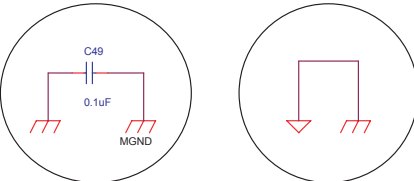
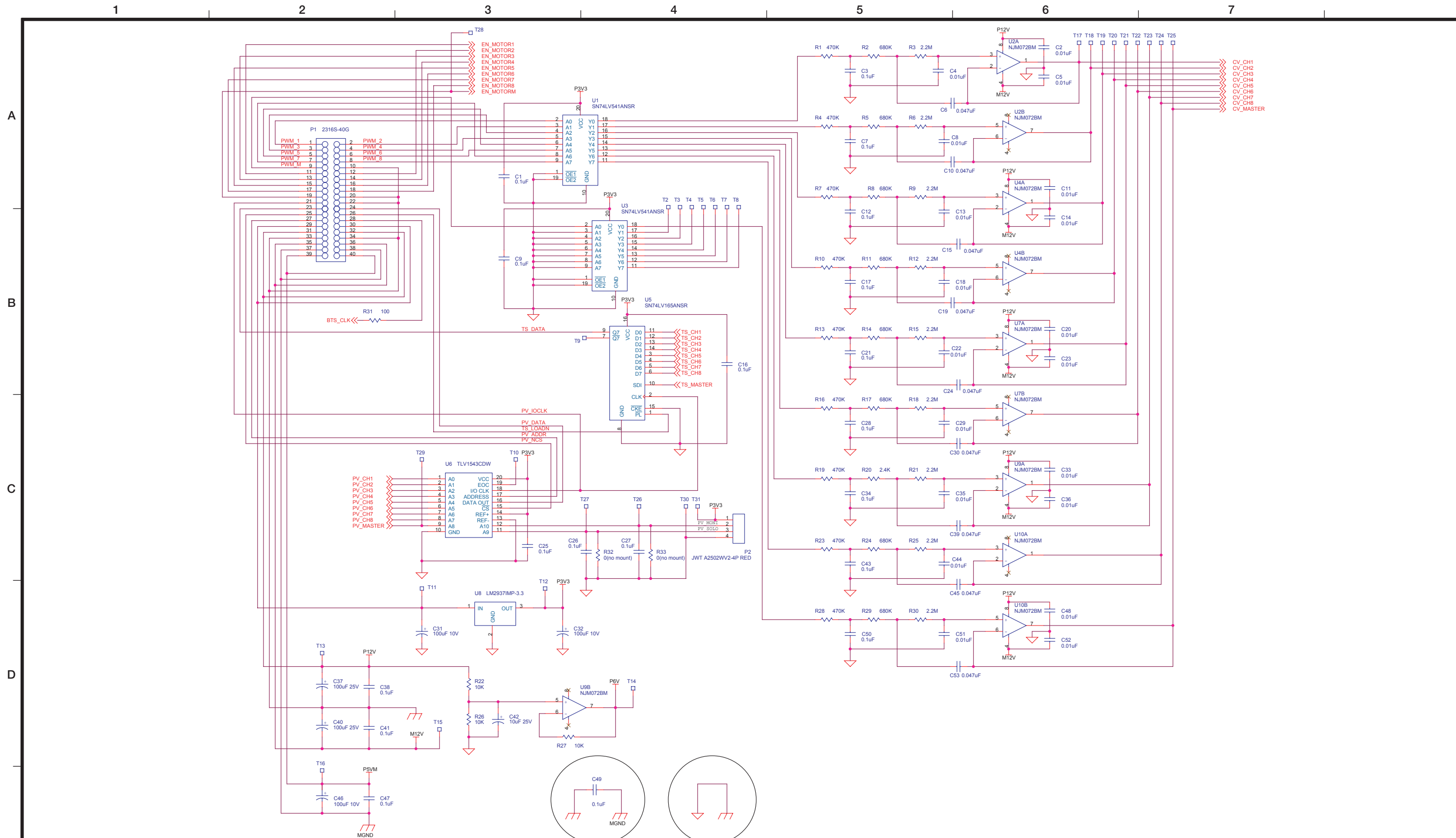

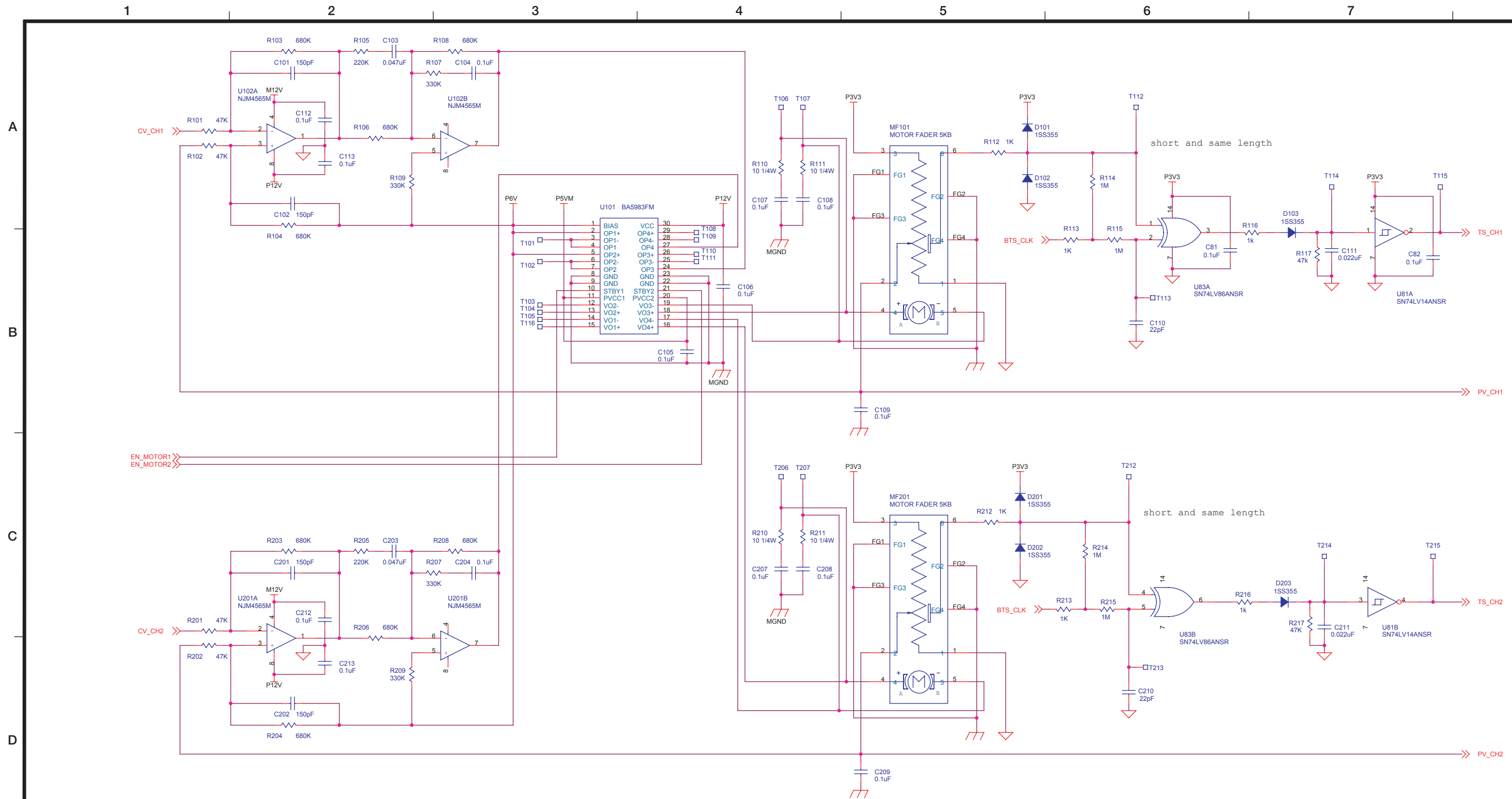

By the channel, a REFERENCE NO is changed as follows.

CH	REFERENCE NO	CH	REFERENCE NO
CH1	R 1 01	CH5	R 5 01
CH2	R 2 01	CH6	R 6 01
CH3	R 3 01	CH7	R 7 01
CH4	R 4 01	CH8	R 8 01

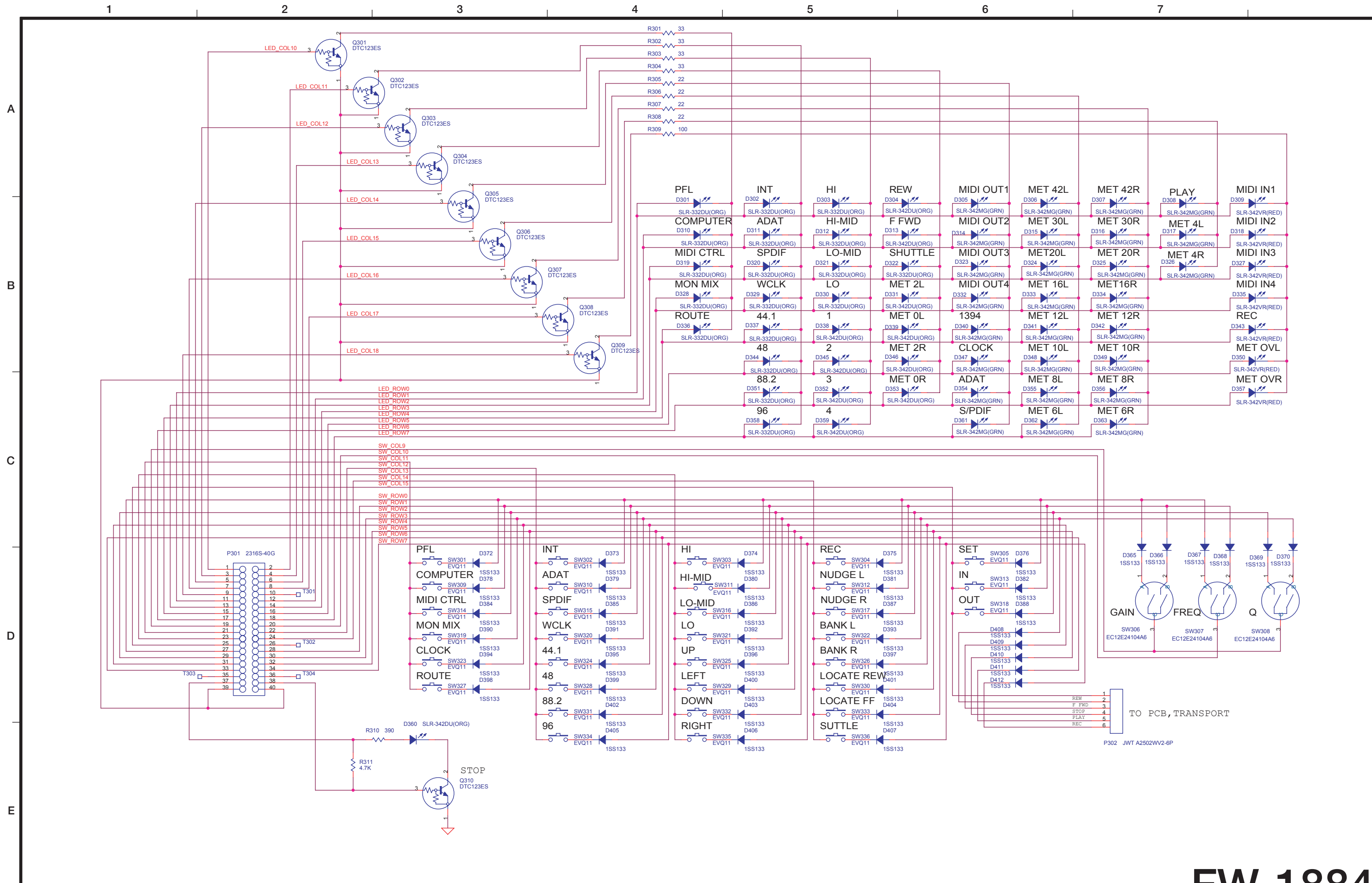

Professional Control Surface/FireWire Audio-MIDI Interface **FW-1884**

1

2

3

4

5

6

7

INLET

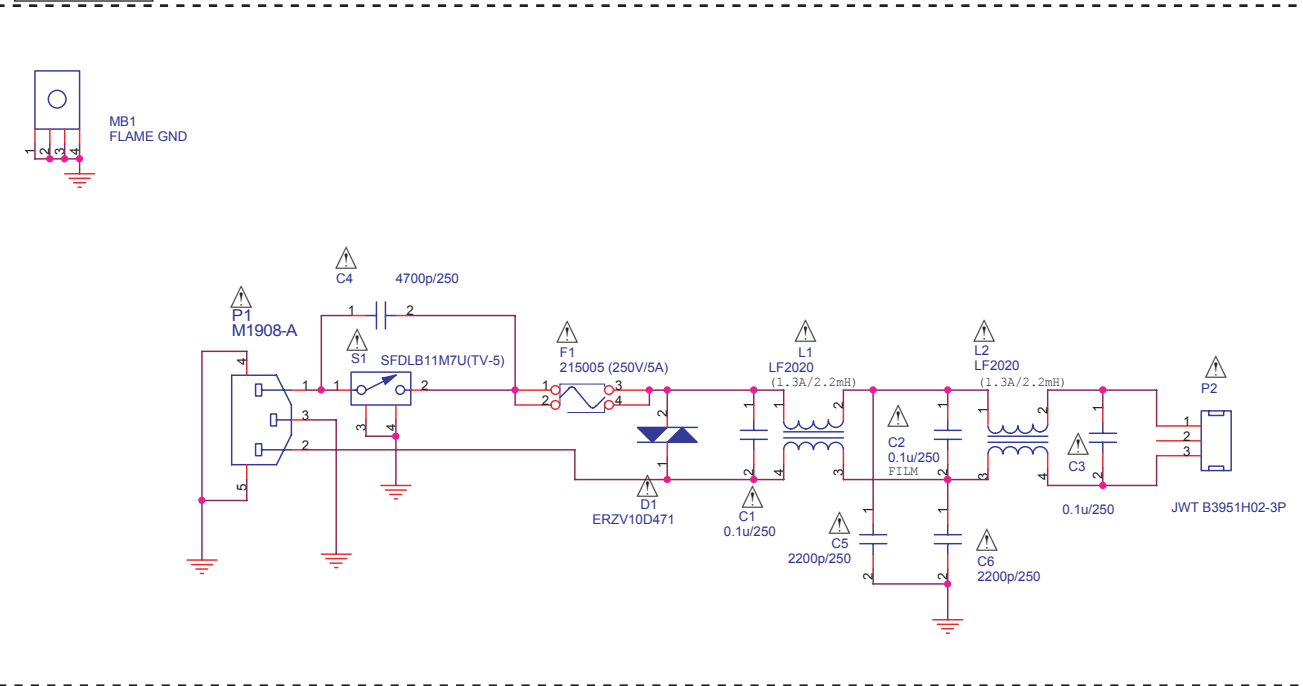

SYNC

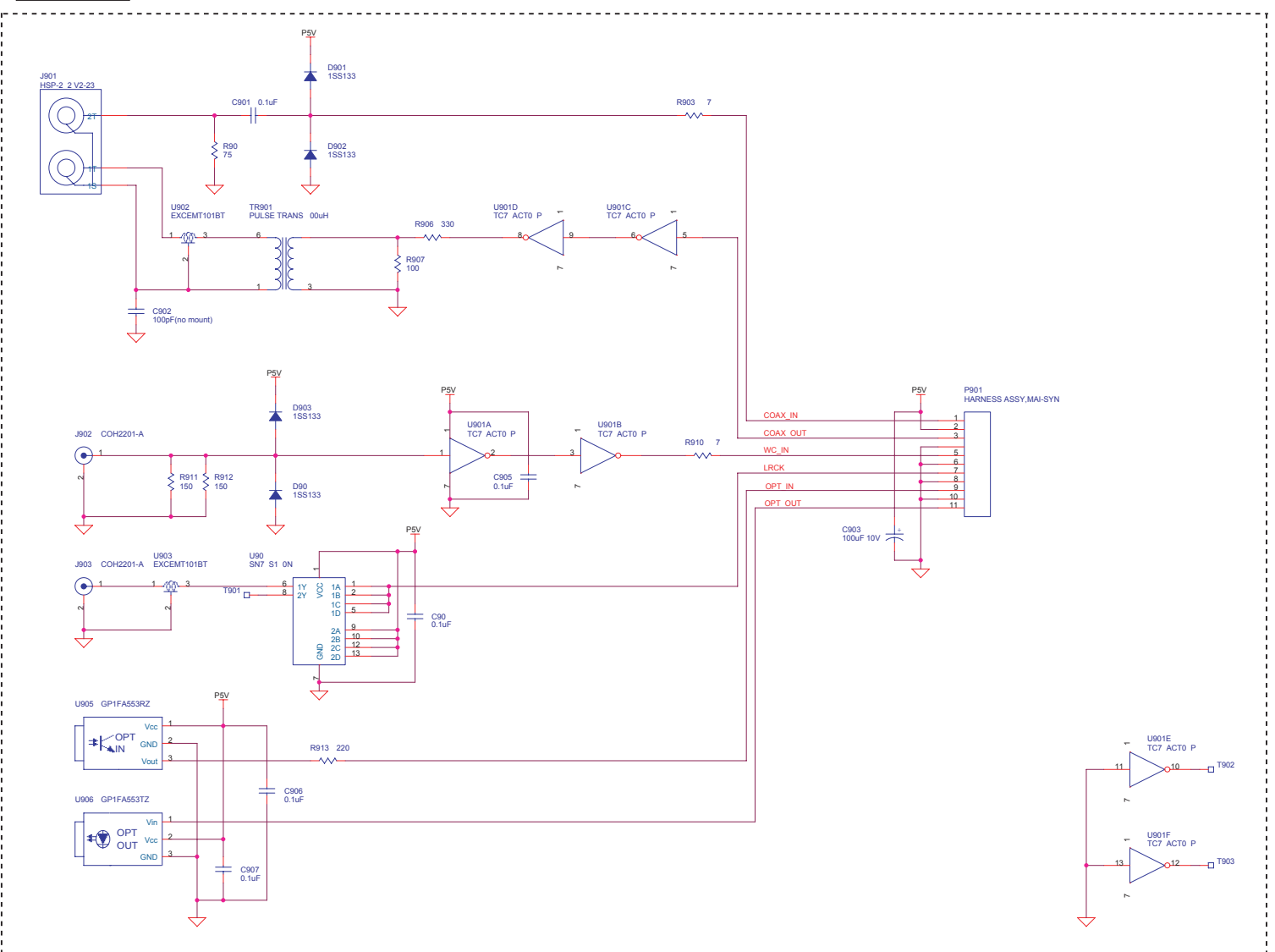

TRANSPORT

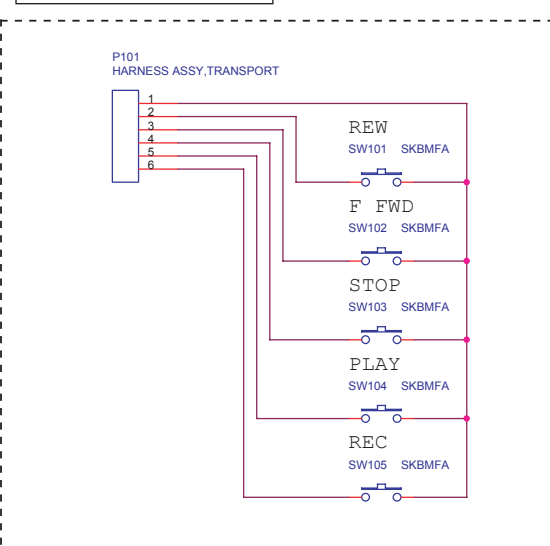

A

B

C

D

E

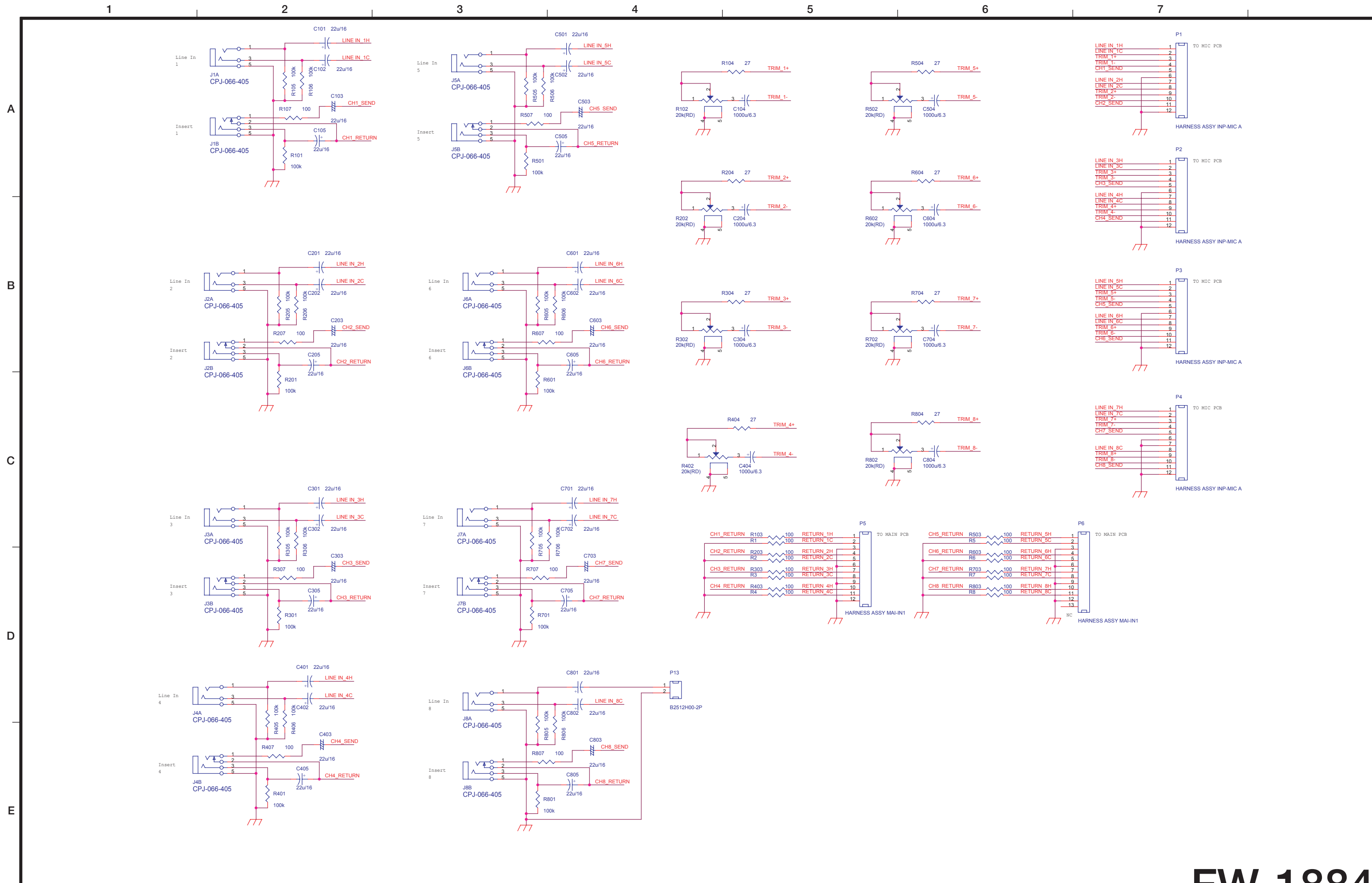

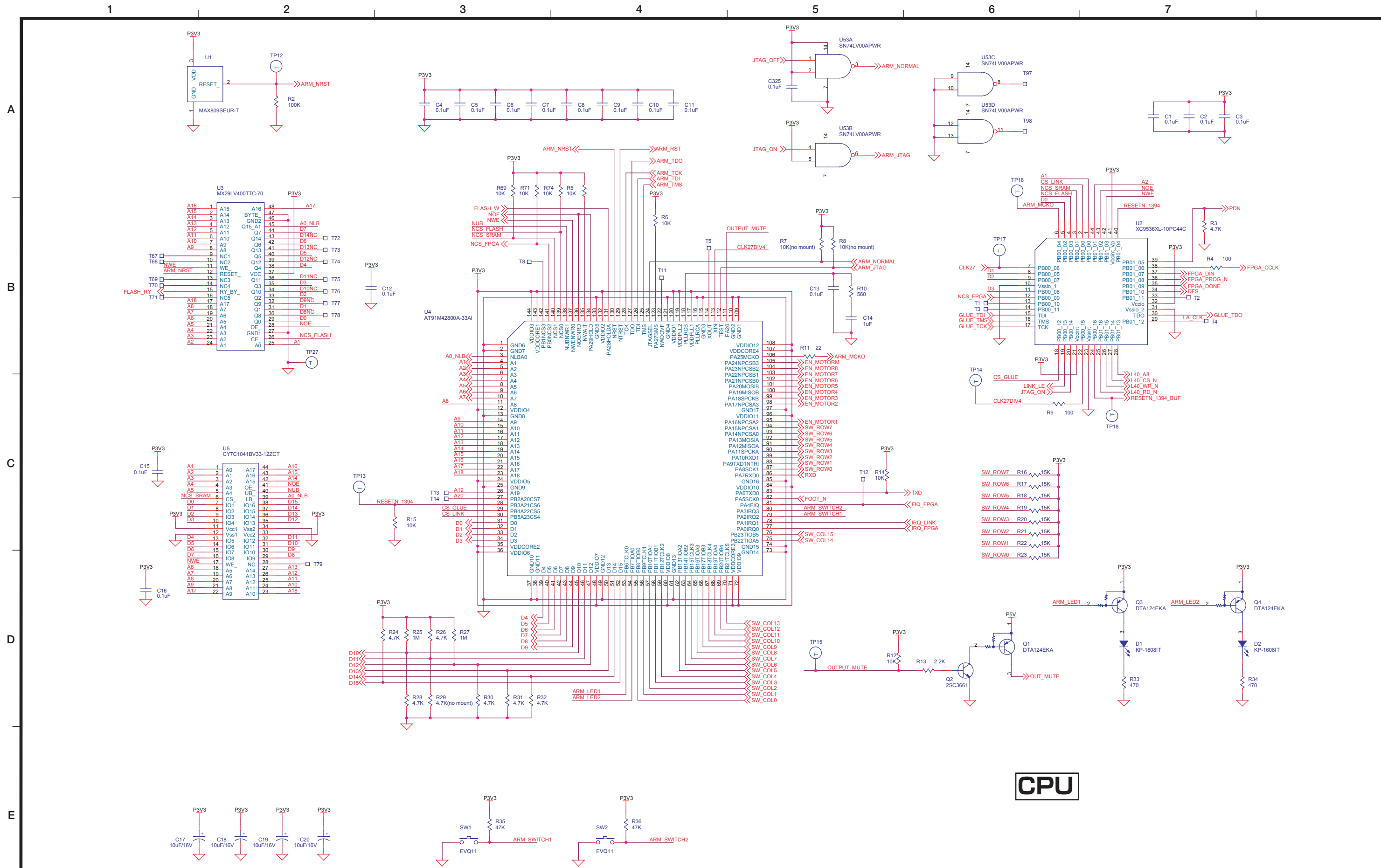

CPU

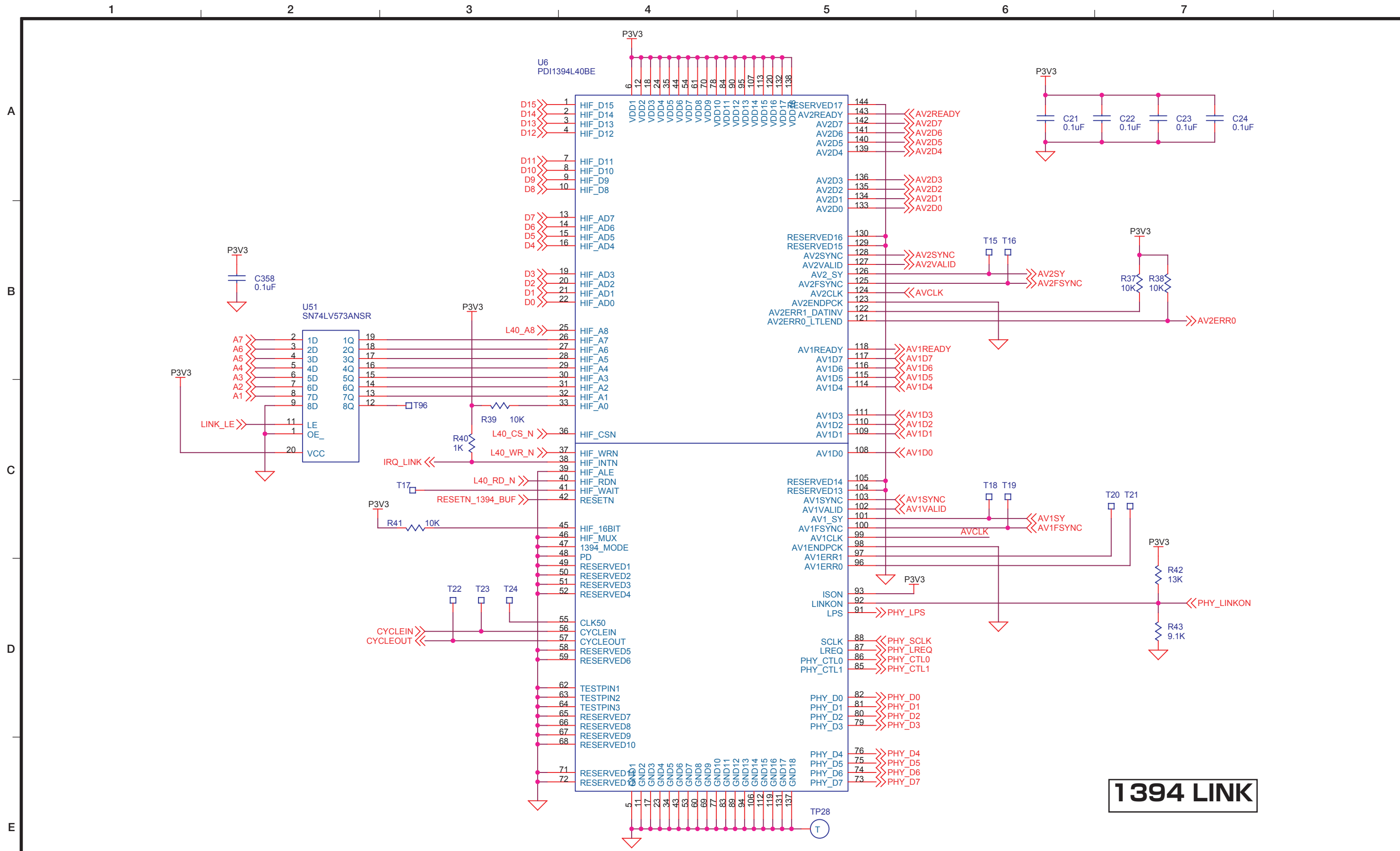

1394 LINK

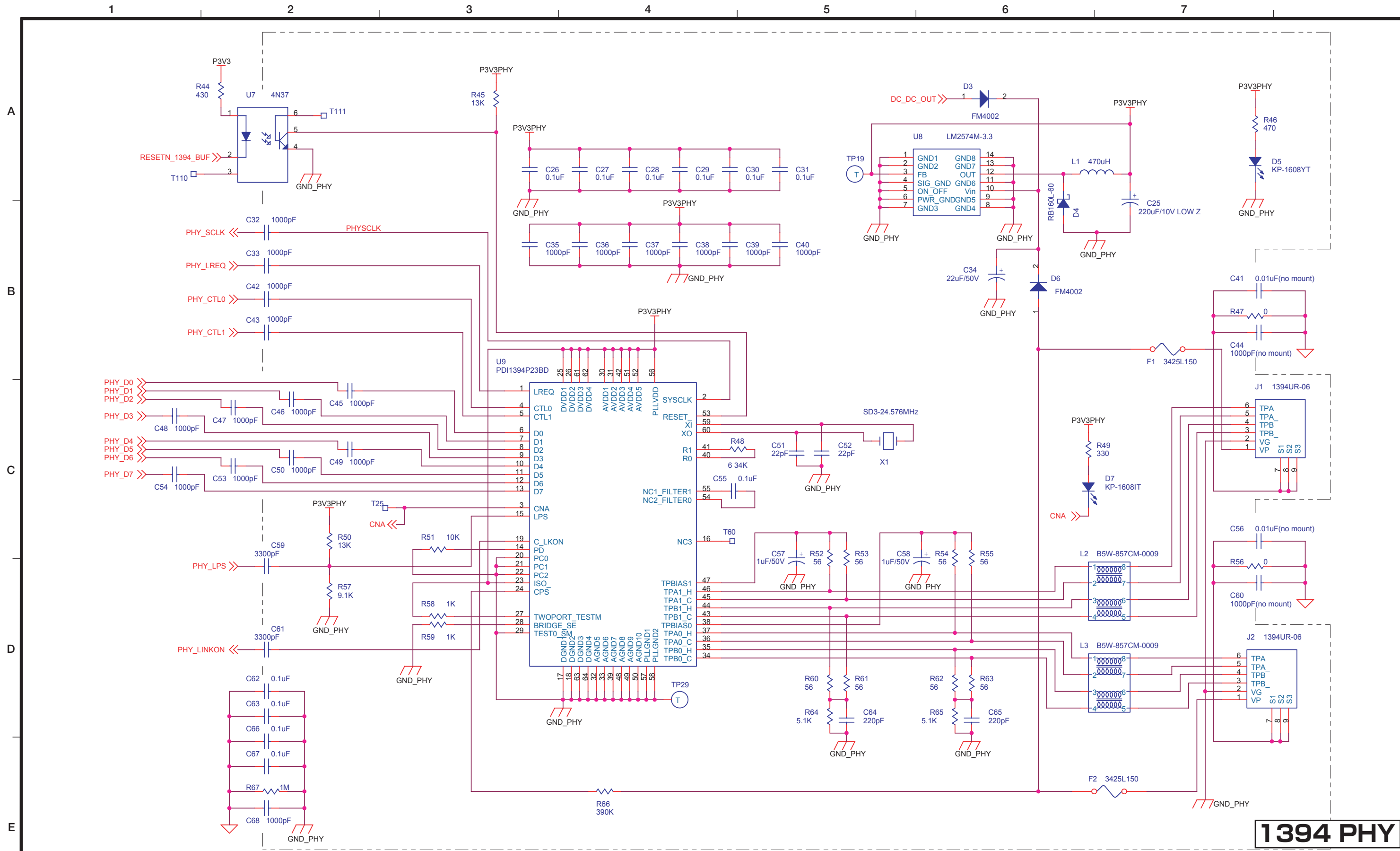

1394 PHY

Professional Control Surface/FireWire Audio-MIDI Interface FW-1844

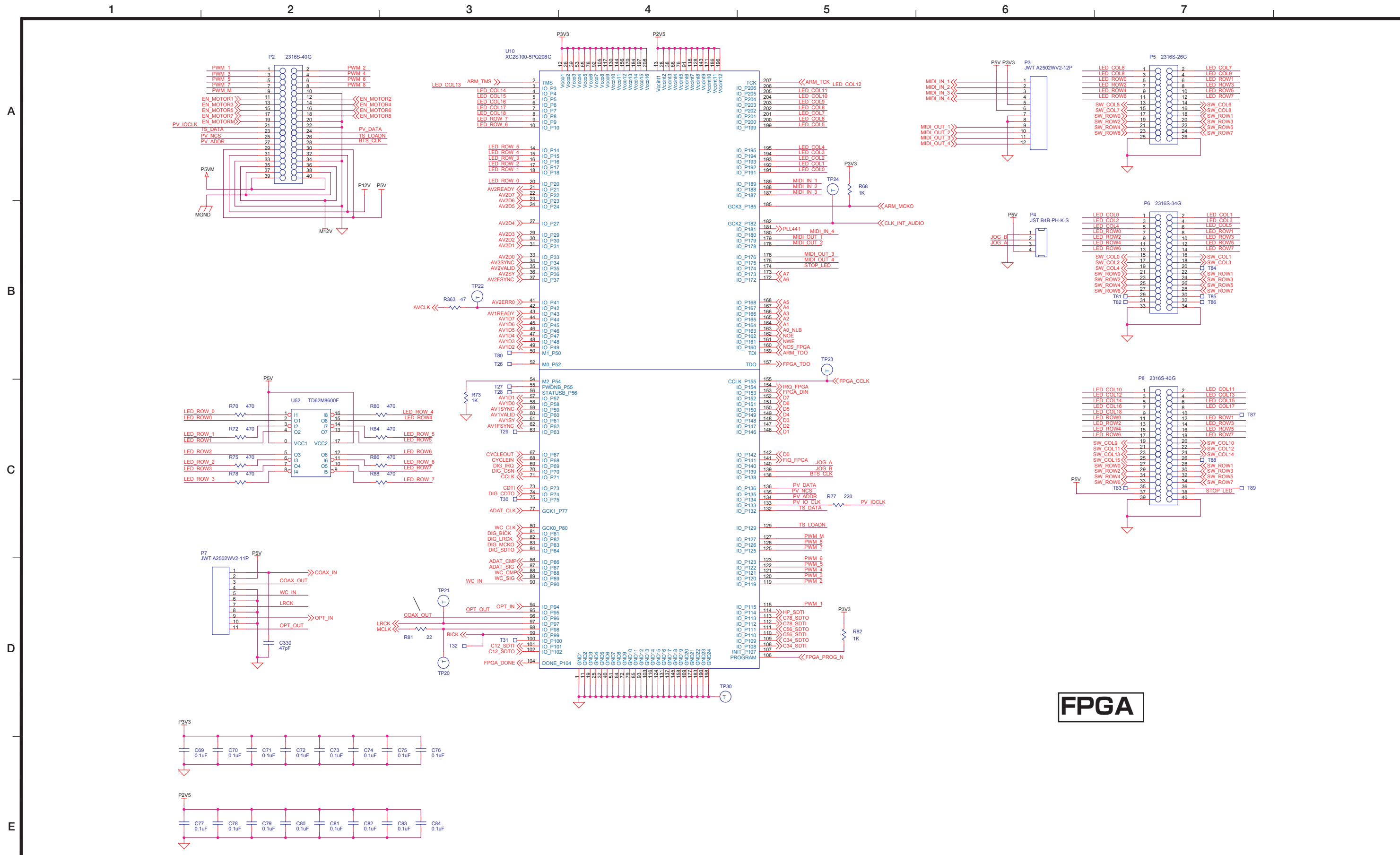

FPGA

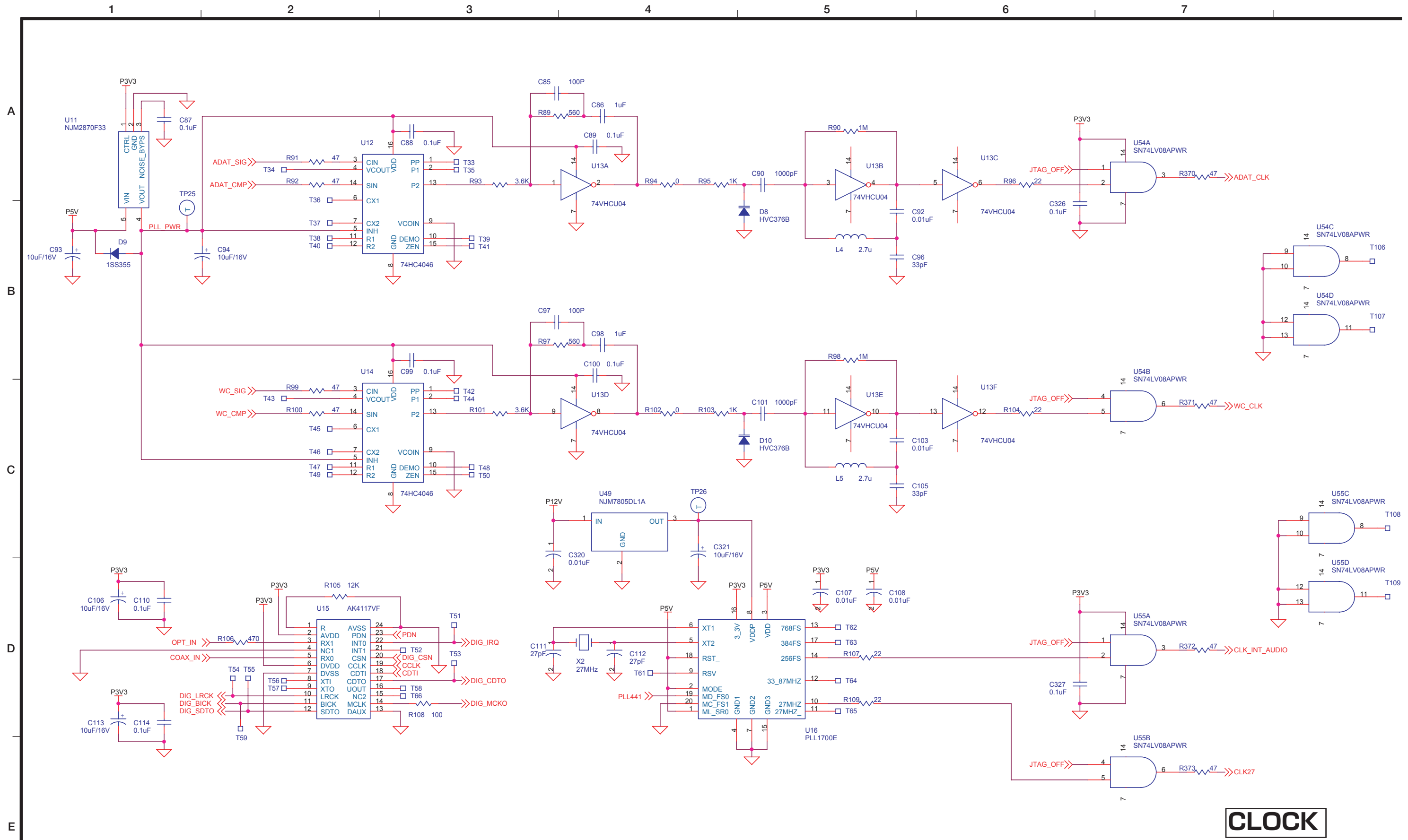

CLOCK

1 2 3 4 5 6 7

CH-1/CH-2
ANALOG

A

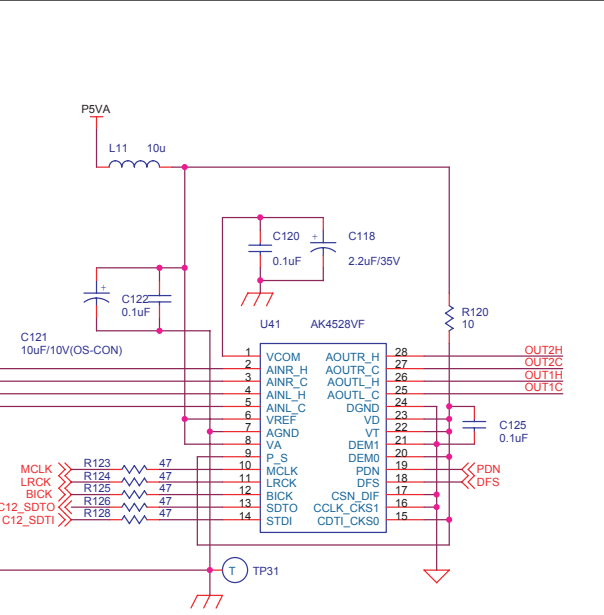
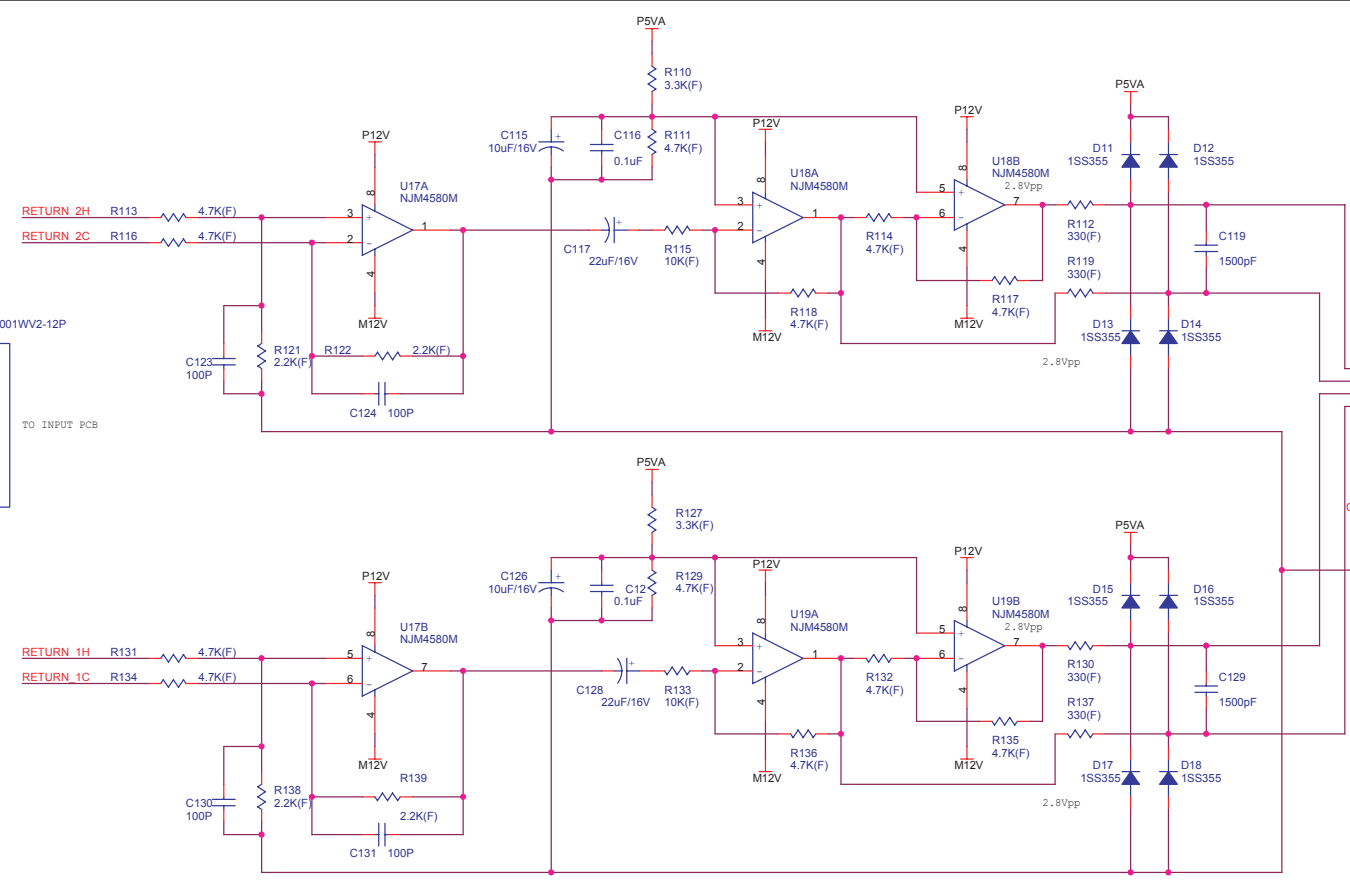
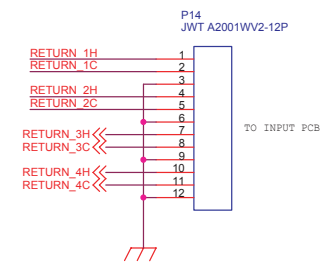

B

C

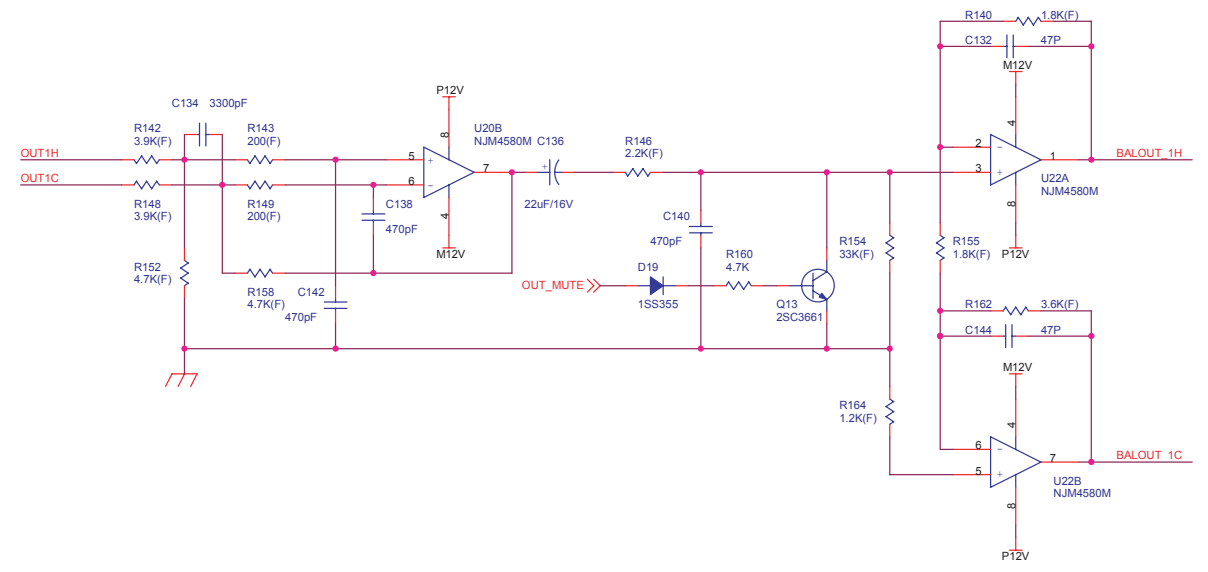
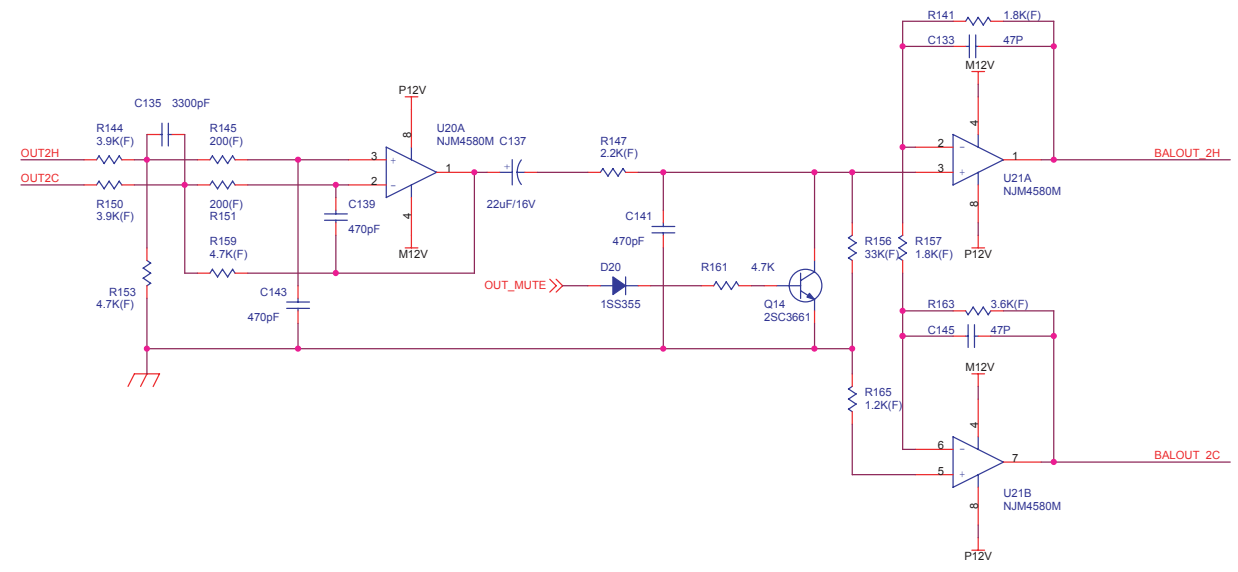

D

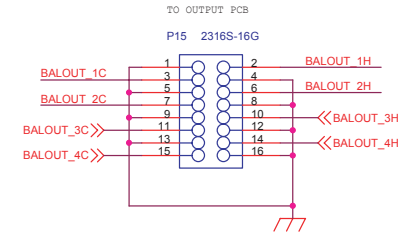
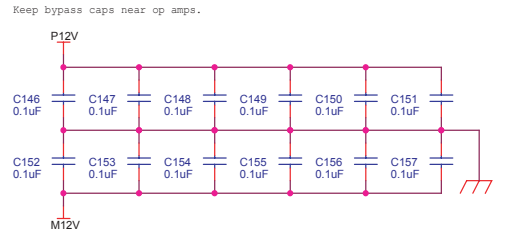

E

CH-3/CH-4
ANALOG

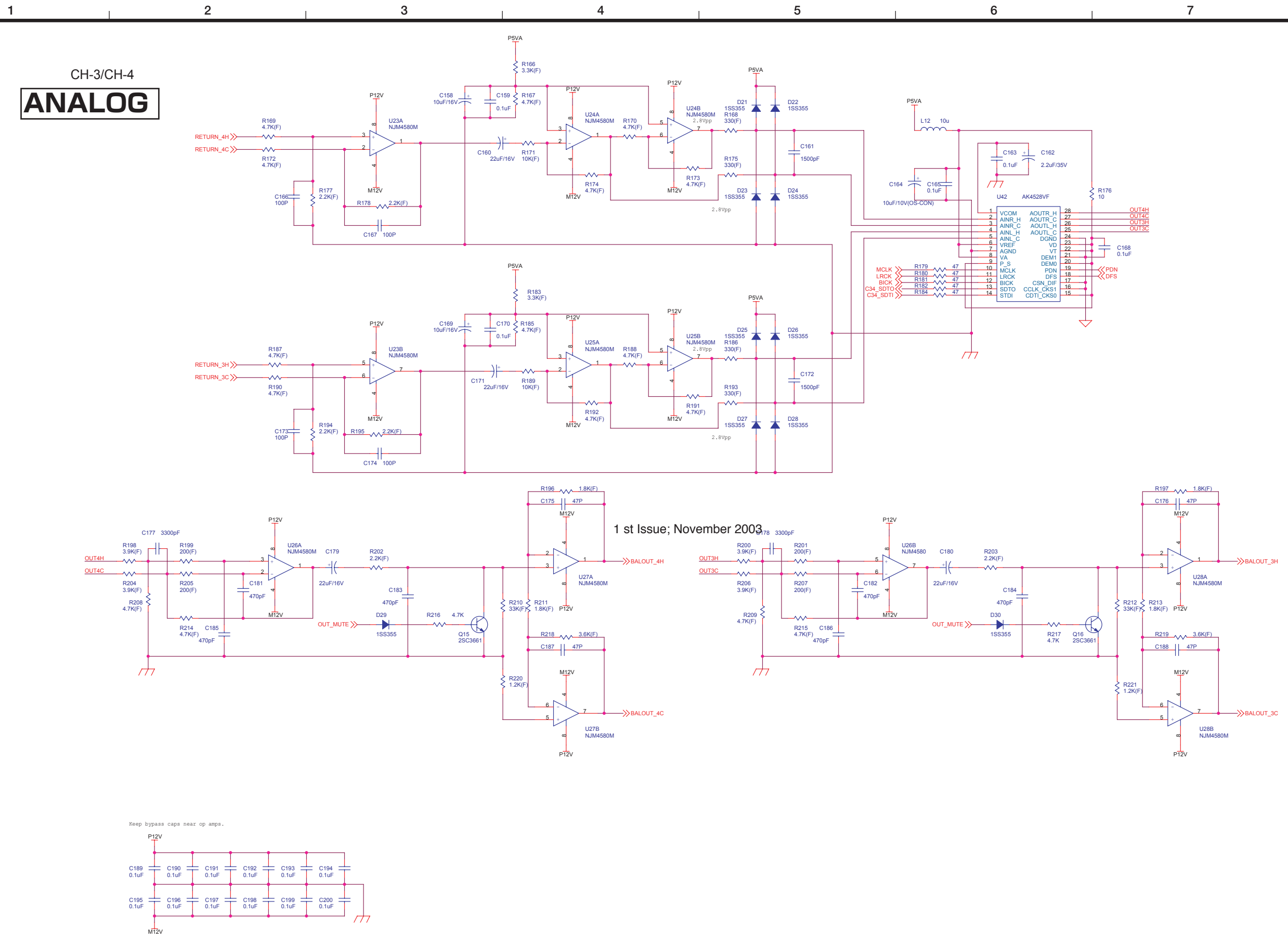

1 st Issue; November 2003

Keep bypass caps near op. amps.

CH-5/CH-6
ANALOG

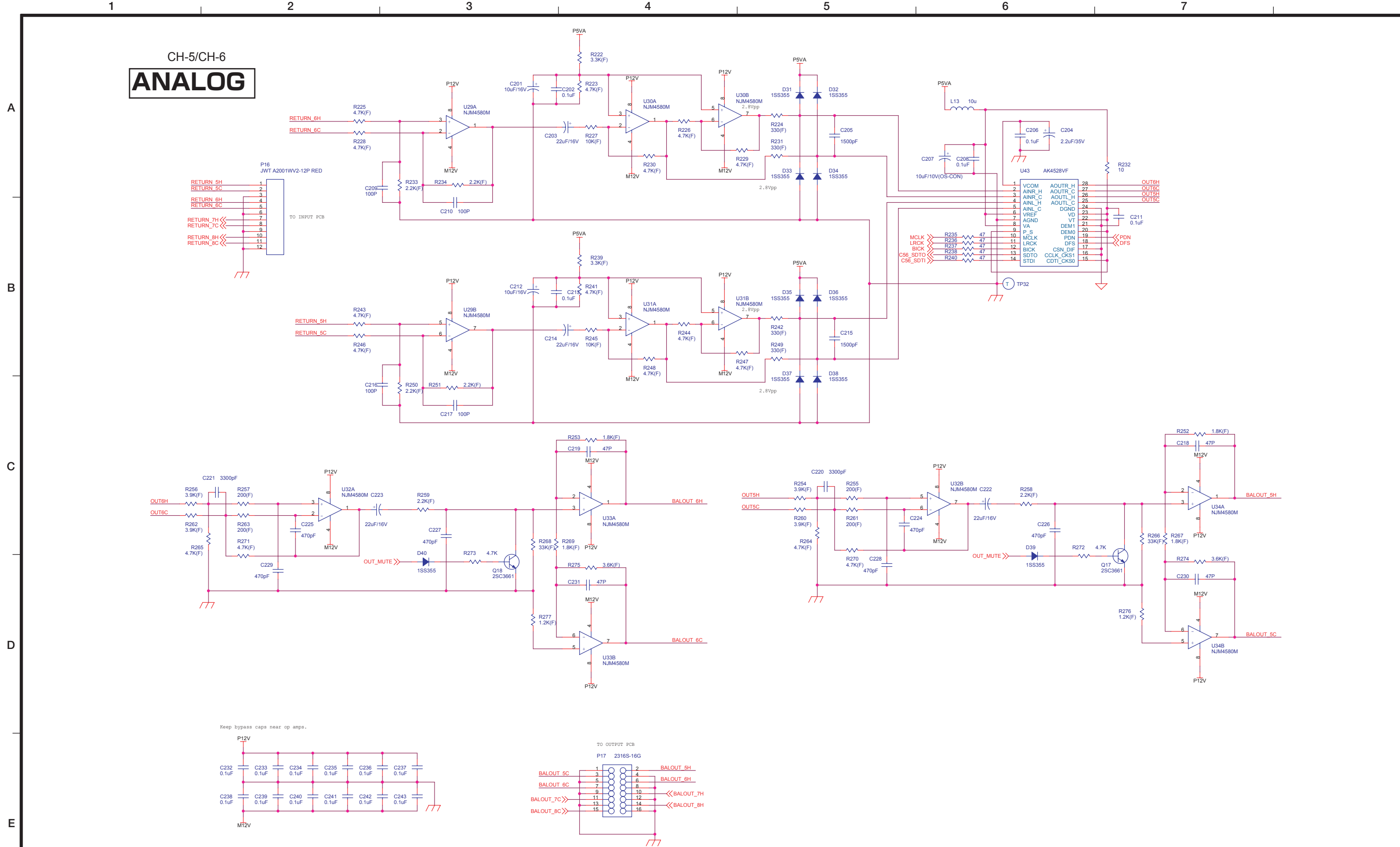

CH-7/CH-8
ANALOG

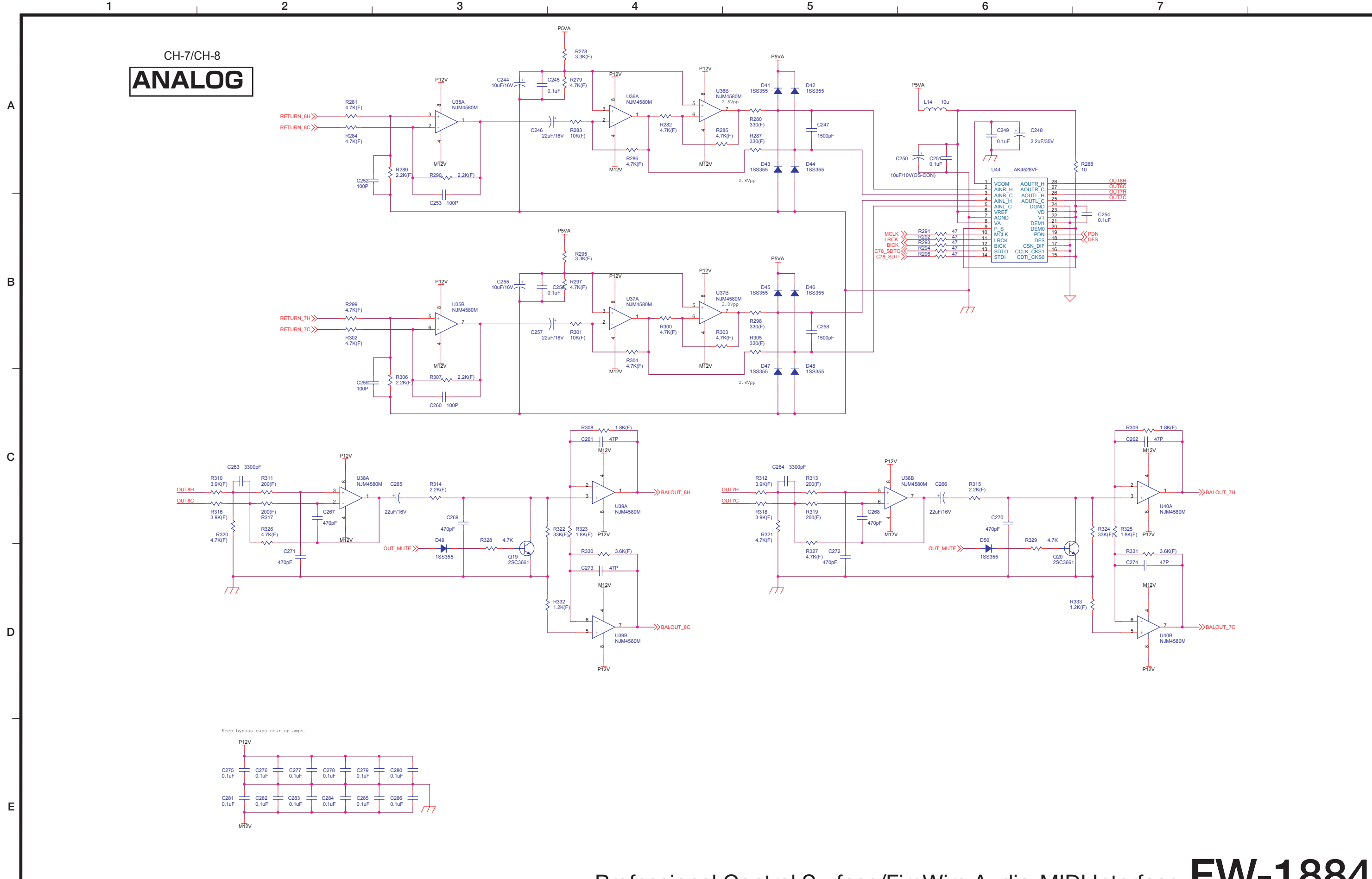

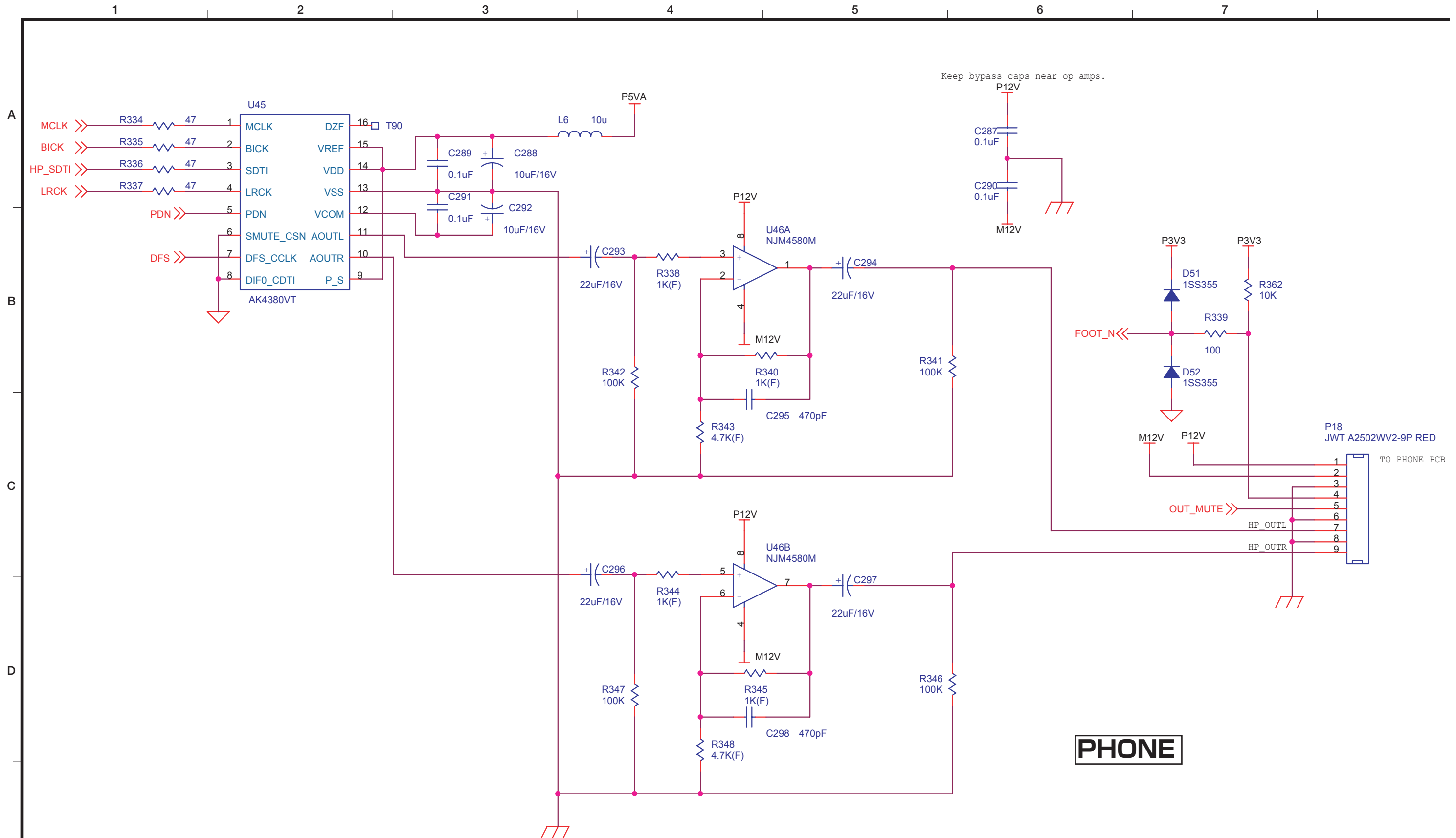

PHONE

1 2 3 4 5 6 7

A

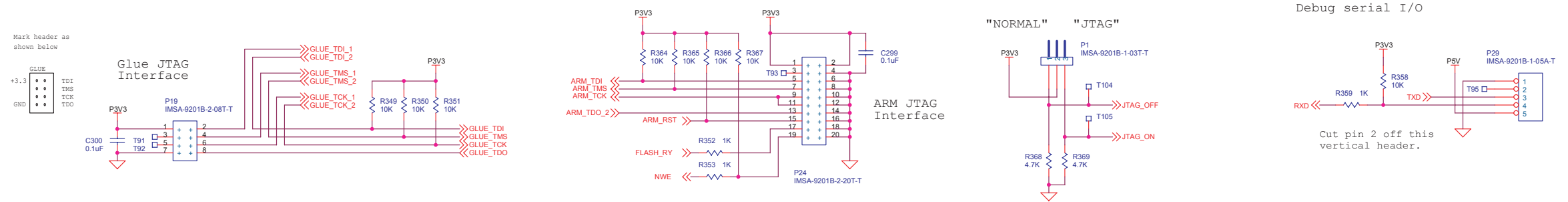

B

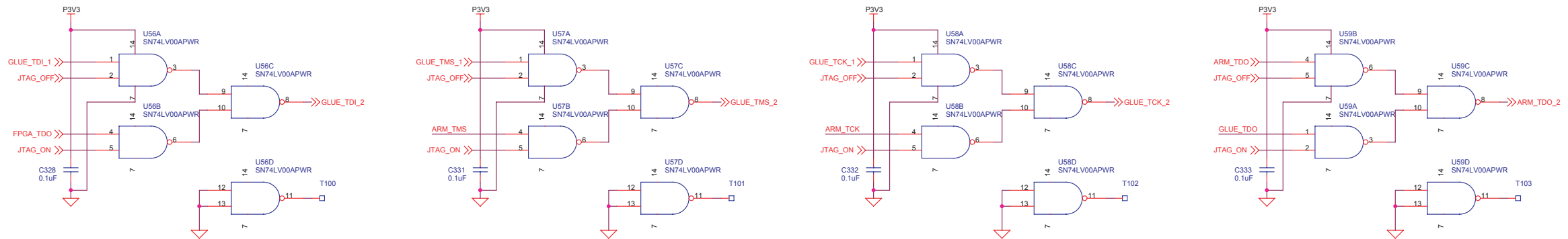

C

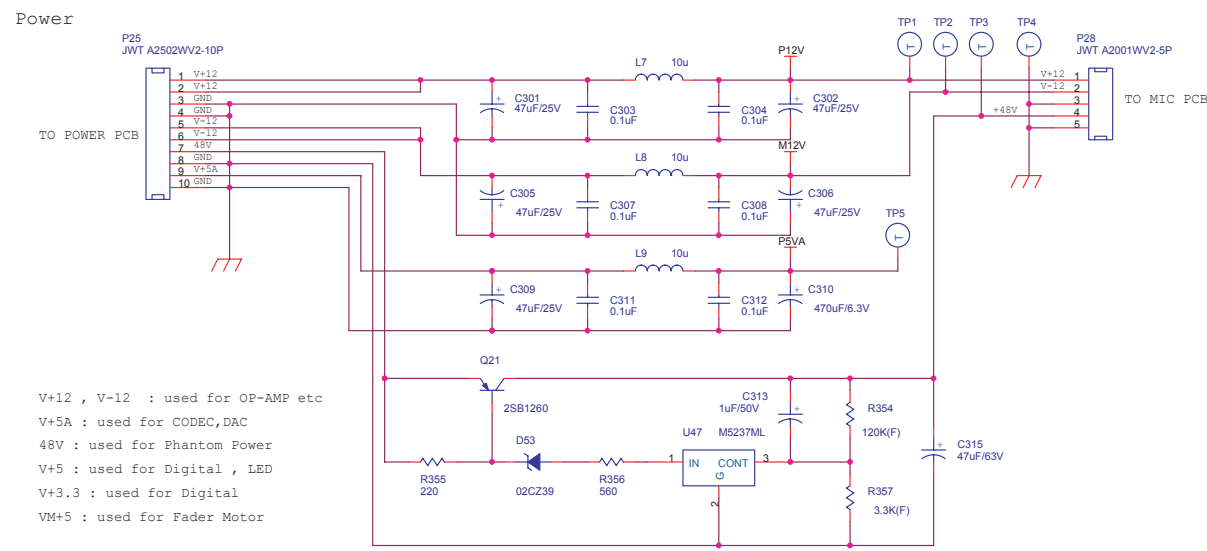

D

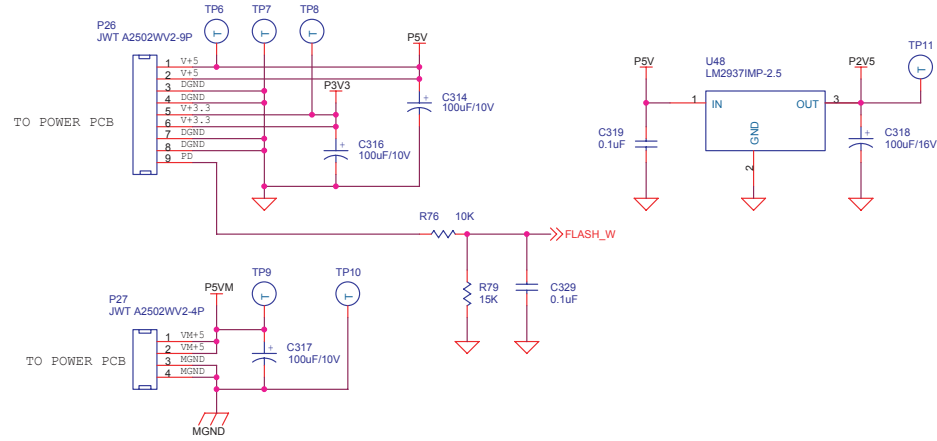

E

POWER & ETC

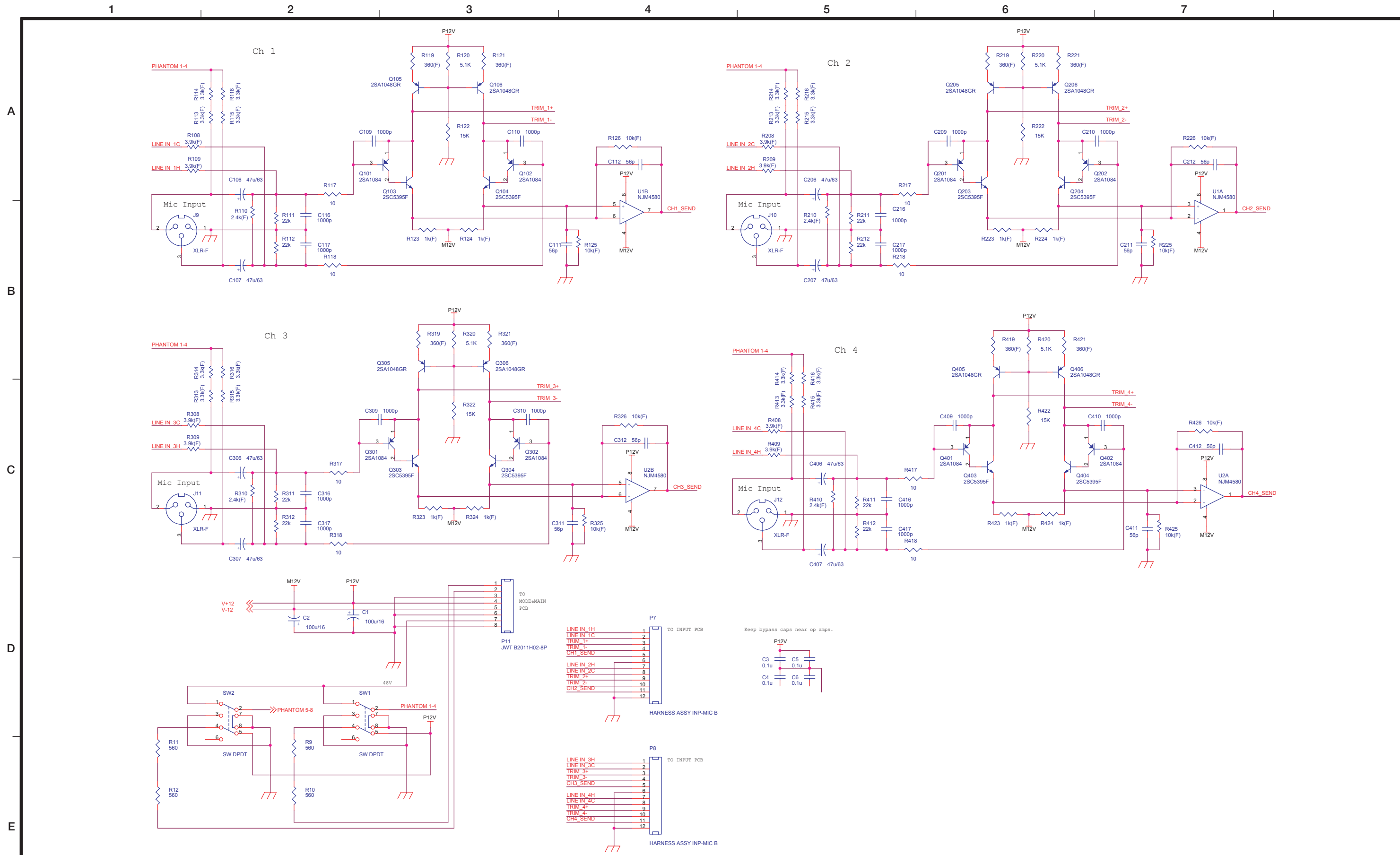

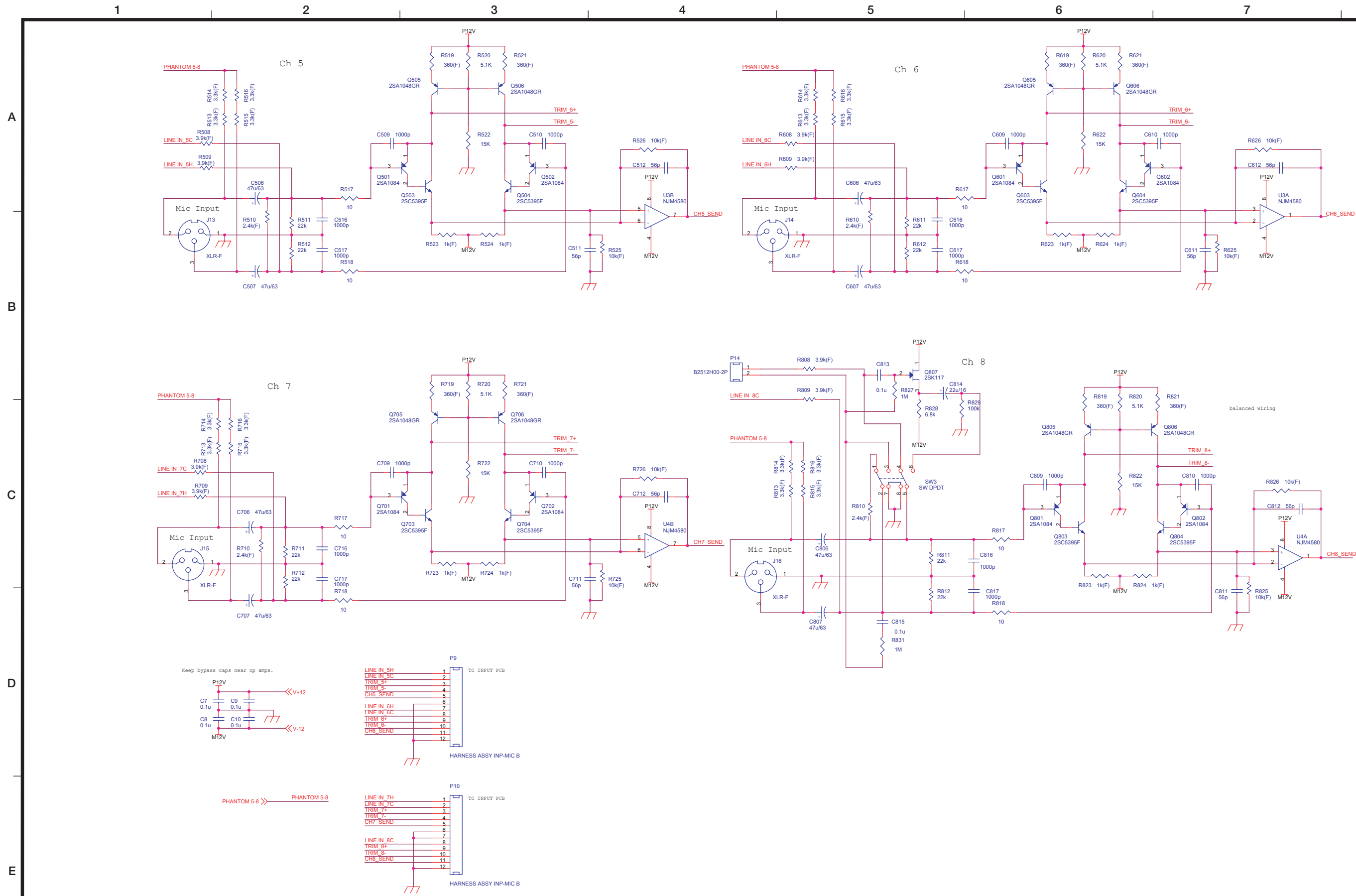

1

2

3

4

5

6

7

MIDI

A

B

C

D

E

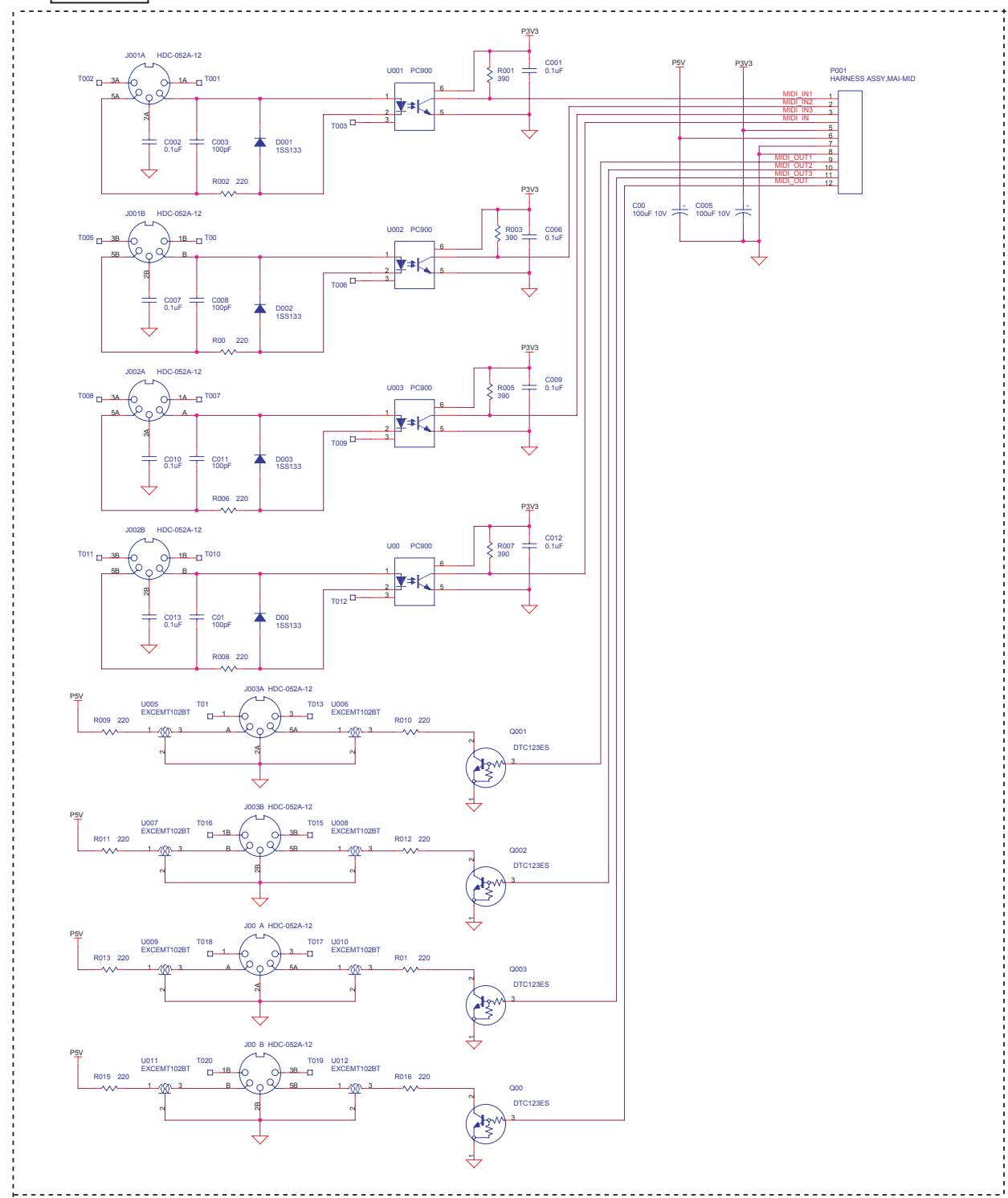

PHONE

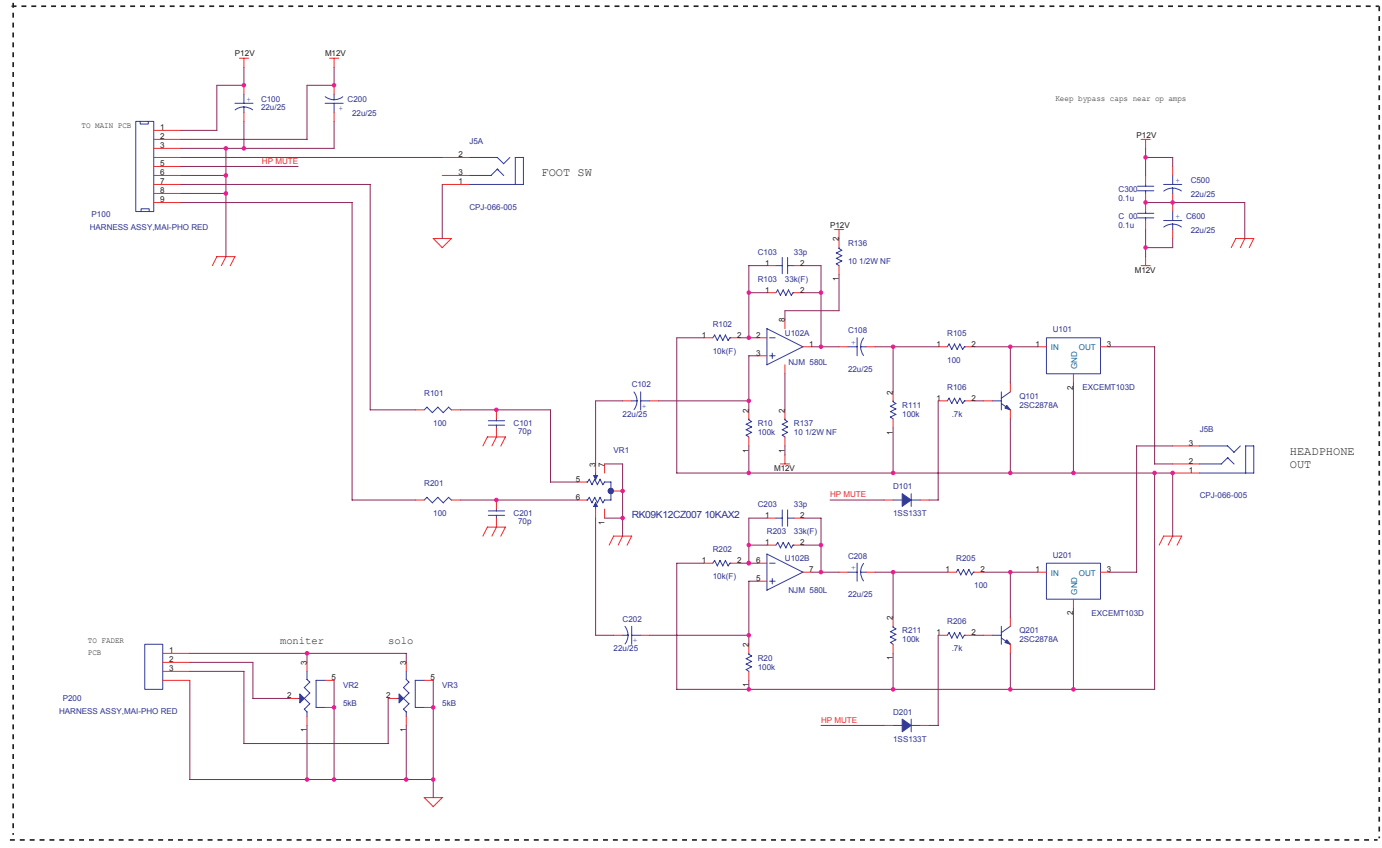

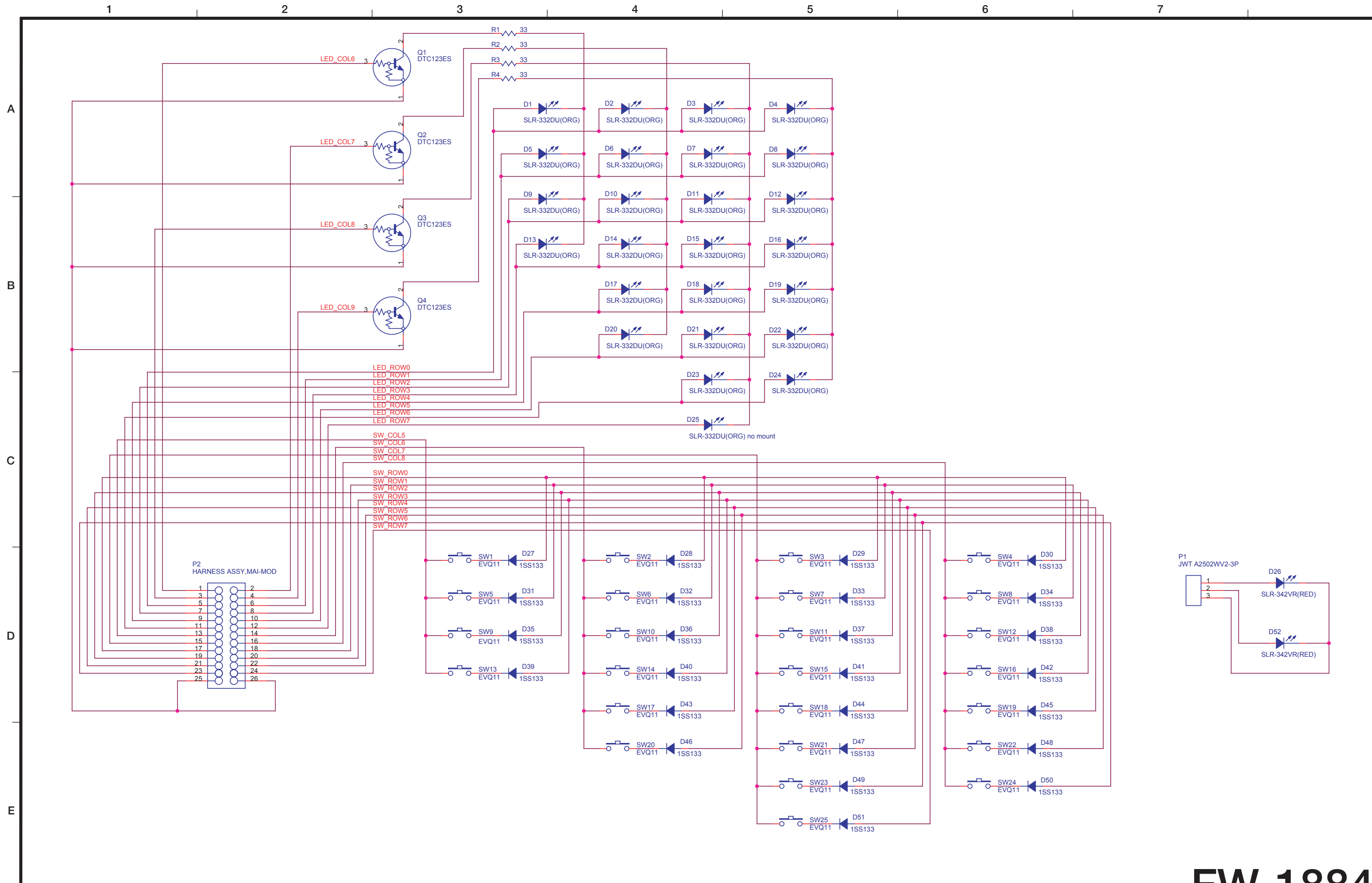

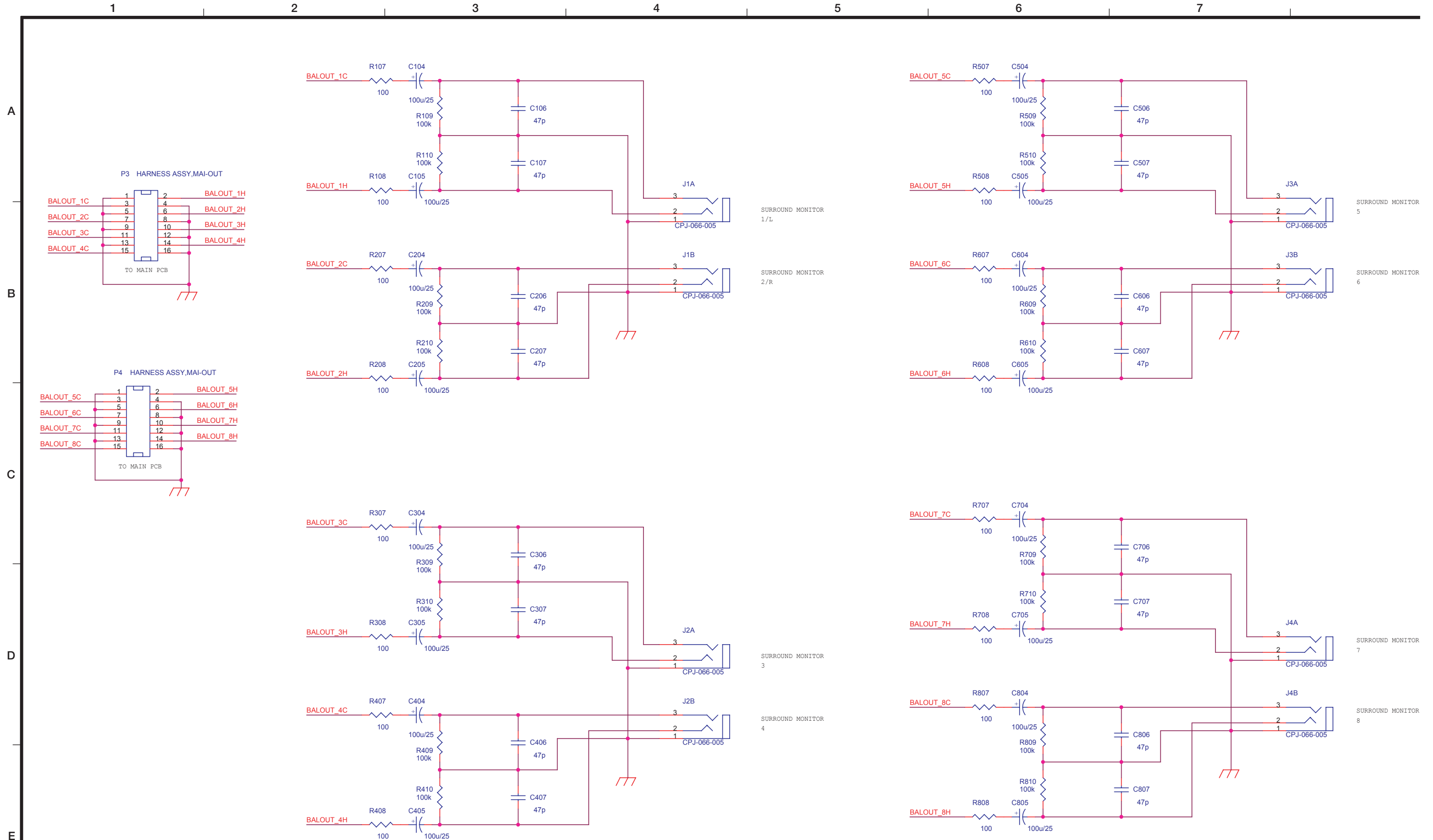

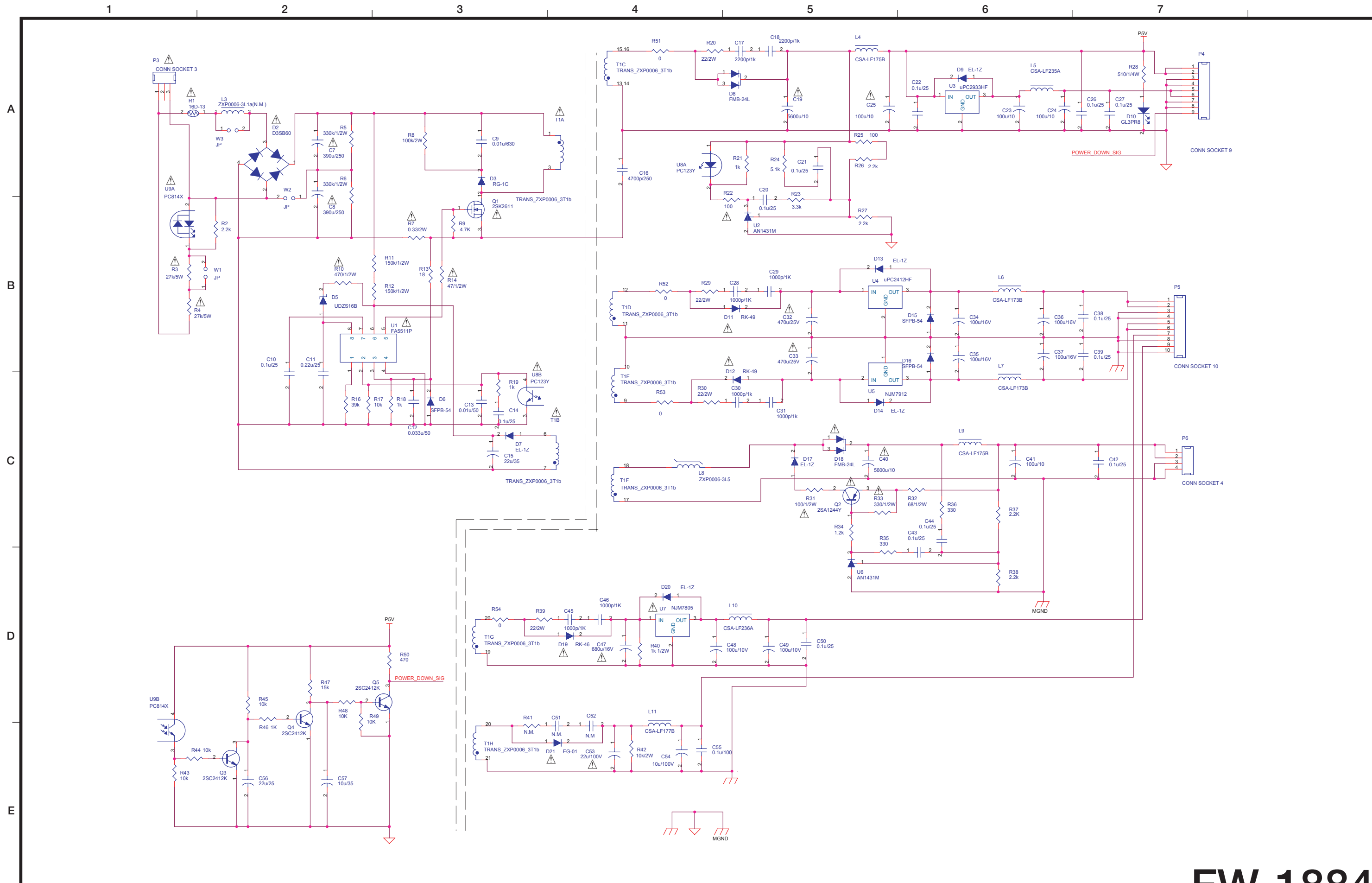

Professional Control Surface/FireWire Audio-MIDI Interface **FW-1884**

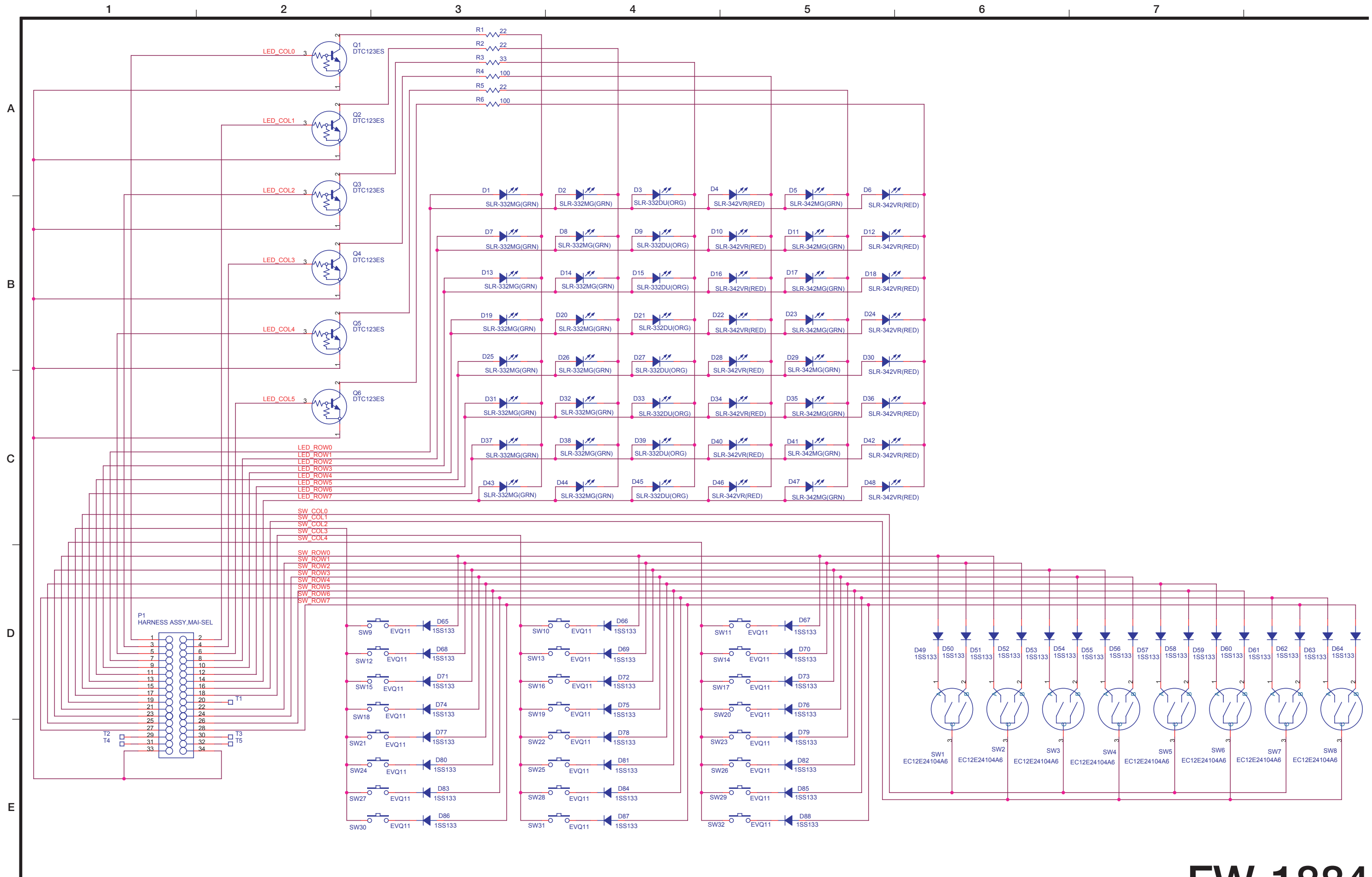

FW-884 Wiring Diagram

