

Service Manual

[TOP NEXT](#)

AD0102028C2

Service Manual

Cassette Deck



RS-DV250

AR-2 Mechanism series

Colour

(S).....Silver Type

Area

(E).....Europe.

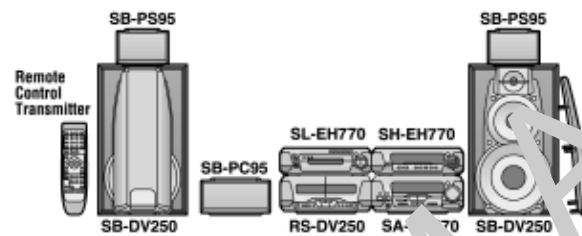

Because of unique interconnecting cables, when a component requires service, send or bring in the entire system.

Manufactured under license from Dolby Laboratories. "Dolby" and the double-D symbol are trademarks of Dolby Laboratories.

System	SC-EH770
Sound Processor	SH-EH770
Tuner/Amplifier	SA-EH770
CD Changer	SL-EH770
Cassette Deck	RS-DV250
Front Speakers*	SB-DV250
Center Speaker*	SB-PC95
Surround Speakers*	SB-PS95

*: Made in Spain.

Specifications

Deck system:	Standard cassette deck	Frequency response (Dolby NR off):	
Track system:	4 track, 2 channel	TYPE I (NORMAL);	20 Hz – 16 kHz (DIN)
Recording system:	AC bias	TYPE II (HIGH);	20 Hz – 16 kHz (DIN)
Bias frequency:	100 kHz	TYPE IV (METAL);	20 Hz – 16 kHz (DIN)
Erasing system:	AC erase	S/N (Signal level = max recording level, TYPE II type tape):	
Heads:		NR off;	56 dB (A weighted)
Deck 1		Dolby B NR on;	66 dB (A weighted)
(Playback head);	Permalloy head	Input sensitivity and impedance:	
Deck 2		REC (IN);	150 mV/ 23 kΩ
(Recording/Playback head);	Permalloy head	Output voltage and impedance:	
(Erasing head);	Double gap ferrite head	PLAY (OUT);	280 mV/ 360 Ω
Motors:		General	
Drive, & Capstan drive;	DC servo motor	Dimensions (WxHxD):	294x118.5x281 mm
Tape speed;	4.8 cm/sec.	Mass:	2.1 kg
Wow and flutter;	0.16 % (WRMS)	Notes:	Specifications are subject to change without notice. Mass and dimensions are approximate.
Fast forward and rewind times:	Approx. 110 seconds with C-60 cassette tape		

© 2001 Matsushita Electric Industrial Co., Ltd. All rights reserved. Unauthorized copying and distribution is a violation of law.

WARNING

This service information is designed for experienced repair technicians only and is not designed for use by the general public. It does not contain warnings or cautions to advise non-technical individuals of potential dangers in attempting to service a product. Products powered by electricity should be serviced or repaired only by experienced professional technicians. Any attempt to service or repair the product or products dealt with in this service information by anyone else could result in serious injury or death.

Technics®

@

[TOP NEXT](#)

5 Service Mode Function of Cassette Mechanism

[TOP](#) [PREVIOUS](#) [NEXT](#)

This unit is equipped with a service mode function of cassette mechanism, so that if the unit operates incorrectly, the fault displayed using an error code on the FL display of the Tuner/Amplifier (SA-EH770). The system control IC and FLdisplay are part of the Tuner/Amplifier so make sure the system has been connected properly before using this function. Use this function during maintenance to check faults of items below.

[5.1 Cassette tape to be prepared](#)

[5.2 Selecting service mode](#)

[5.3 Deck 1 mechanism check](#)

[5.4 Deck 2 mechanism check](#)

[5.5 Exiting service mode](#)

@

[TOP](#) [PREVIOUS](#) [NEXT](#)

SCHEMA 99

5.1 Cassette tape to be prepared

[TOP](#) [PREVIOUS](#) [NEXT](#)

- ┆ [Metal tape:](#)

Recorded music tape with only one erasure prevention tab intact./(use middle portion of tape)

- ┆ [Normal tape: /CrO2 tape:](#)

Recorded music tape with both erasure prevention tabs intact./(use middle portion of tape)

@

[TOP](#) [PREVIOUS](#) [NEXT](#)

SCHEMA 99

5.2 Selecting service mode

[TOP PREVIOUS NEXT](#)

1. Turn on the power to the unit.
2. Make sure that no tape is inserted in the cassette deck. (Service mode cannot be selected with a tape inserted in the cassette deck.)
3. Press the DOLBY NR button for about 2 seconds, and keep pressing it, also press the STOP button for about 2 seconds. Refer to [Fig. 5-1](#).

Fig. 5-1.

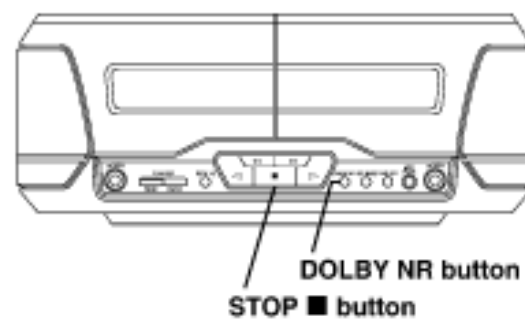

@

[TOP PREVIOUS NEXT](#)

5.3 Deck 1 mechanism check

[TOP](#) [PREVIOUS](#) [NEXT](#)

1. Press the Deck 1/deck 2 select button to change the flashing Deck 2 indicator to Deck 1. Refer to [Fig. 5-2](#). /(No change required if Deck 1 indicator already flashing.)
2. Press the Deck 1 cassette holder open button to open the Deck 1 cassette holder. Refer to [Fig. 5-2](#).
3. Insert a CrO2 tape into the Deck 1 and close the cassette holder.
4. Press the Fast forward button. Refer to [Fig. 5-2](#). /(Tape fast forwards for about 2 seconds then stops.)
5. Press the PLAY button. Refer to [Fig. 5-2](#). /(After TPS operation and check, the tape stops.)
6. Open the Deck 1 cassette holder and replace the tape with a normal tape.
7. Close the Deck 1 cassette holder.
8. Press the Record pause button. Refer to [Fig. 5-2](#). /(No record operation.)
9. Press the STOP button. Refer to [Fig. 5-2](#). A mechanism error code is displayed. Refer to Table 5-1. Each time the STOP button is pressed, the fault items are displayed in sequence.

Fig. 5-2.

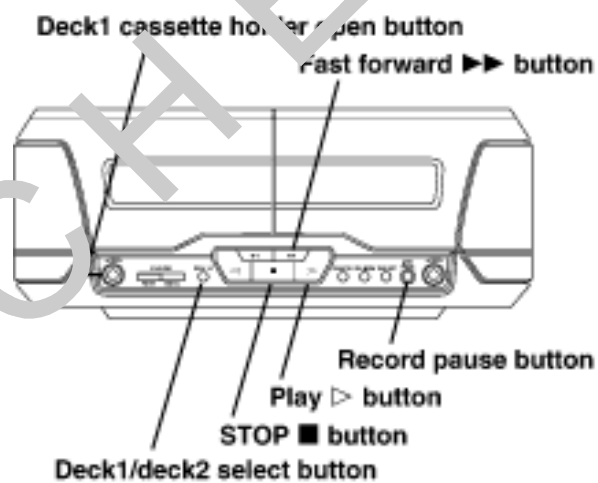

Table 5-1.

FL display	Symptom	Cause
H01	Cassette deck does not operate correctly.	Faulty cassette deck mechanism mode detect switch (Deck 1: S951, Deck 2: S971), plunger and capstan motor. /(Check and replace)
H02	Unit does not record or the unit goes into recording mode even when the erasure prevention tabs have been removed from the cassette.	Faulty erasure prevention tabs detect switch (S974, S975) or short-circuit. (Check and replace)
H03	Tape does not play even when the tape deck play button is pressed. The motor operates when the tape deck play button is pressed even if cassette is loaded in the deck.	Faulty tape detect switch (Deck 1: S952 Deck 2: S972) or short-circuit. (Check and replace)
H06	Cassette deck does not detect CrO2 tape.	Faulty CrO2 tape detect switch (Deck 1: S953, Deck 2: S973)./(Check and replace)
H07	Cassette deck does not detect Metal tape.	Faulty Metal tape detect switch (S976). (Check and replace)
F01	When the tape play button is pressed, tape advances only slightly and then stops.	Reel pulse error (Faulty Hall IC). (Check and replace)
F02	TPS (tape program search) does not work.	Faulty TPS signal detection or faulty plunger control. /(Check and replace mechanism control IC)

5.4 Deck 2 mechanism check

[TOP](#) [PREVIOUS](#) [NEXT](#)

1. Press the Deck 1/deck 2 select button to change the flashing Deck 1 indicator to Deck 2. Refer to [Fig. 5-3](#).
2. Press the Deck 2 cassette holder open button to open the Deck 2 cassette holder. Refer to [Fig. 5-3](#).
3. Insert a metal tape into the Deck 2 with an intact erasure prevention tab on the right side.
4. Close the Deck 2 cassette holder.
5. Press the Fast forward button. Refer to [Fig. 5-3](#). (Tape fast forwards for about 2 seconds then stops.)
6. Open the Deck 2 cassette holder and turn over the metal tape. (intact erasure prevention tab on the left side.)
7. Close the Deck 2 cassette holder.
8. Press the Rewind button. Refer to [Fig. 5-3](#). (Tape rewinds for about 2 seconds then stops.)
9. Open the Deck 2 cassette holder and replace the metal tape with a CrO2 tape.
10. Close the Deck 2 cassette holder.
11. Press the PLAY button. Refer to [Fig. 5-3](#). (After TPS operation and check, the tape stops.)
12. Open the Deck 2 cassette holder and replace the CrO2 tape with a normal tape.
13. Close the Deck 2 cassette holder.
14. Press the Record pause button. Refer to [Fig. 5-3](#). (No record operation.)
15. Press the STOP button. Refer to [Fig. 5-3](#). A mechanism error code is displayed. Refer to Table 5-1. Each time the STOP button is pressed, the fault items are displayed in sequence.

Fig. 5-3.

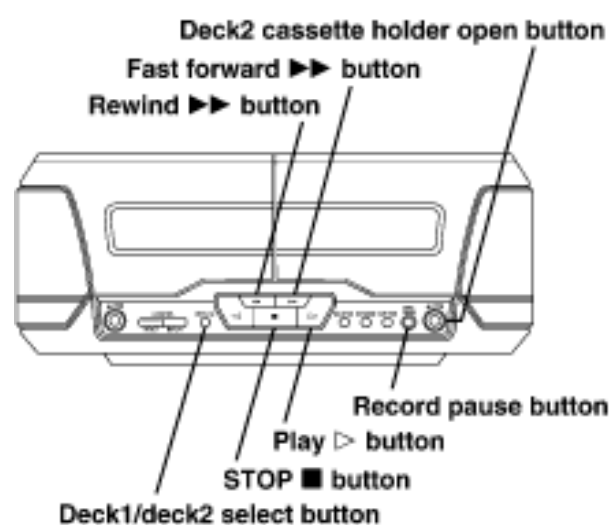

5.5 Exiting service mode

[TOP](#) [PREVIOUS](#) [NEXT](#)

1. Press the STOP button for more than 5 seconds (Diagnostic contents stored in memory for both Deck 1 and 2 are erased.)
2. Remove the cassette tape from the cassette holder.
3. Turn off the unit.

@

[TOP](#) [PREVIOUS](#) [NEXT](#)

SCHEMA 99

13.3 Head azimuth adjustment (Deck 1/2)

[TOP](#) [PREVIOUS](#) [NEXT](#)

1. Connect the measuring instrument as shown in [Fig. 13-1](#).
2. Replace azimuth screws for both forward and reverse directions after removing the screw-locking bond left on the head base. (Supply part No. of azimuth screw: [RHD17015](#))
3. Playback the azimuth adjustment portion (8 kHz, -20 dB) of test tape (QZZCFM). Adjust the azimuth screw until the outputs of the L/R ch are maximized. Refer to [Fig. 13-2](#). Make sure that the difference in the peak level between the left and right channels does not exceed 0.5 dB.
4. Perform the same adjustment in reverse playback mode.

[Check of the level difference forward and reverse directions.](#)

5. Playback the playback gain adjustment portion (315 Hz, 0 dB) of test tape (QZZCFM). Check if level difference between forward and reverse direction is within 1.5 dB.
6. After the adjustment, apply screw lock to the azimuth screw.

Fig. 13-1.

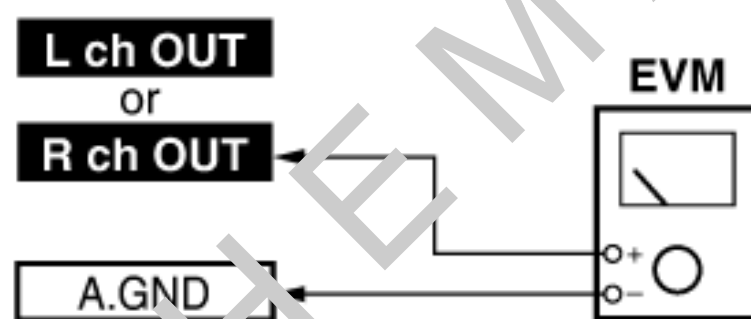
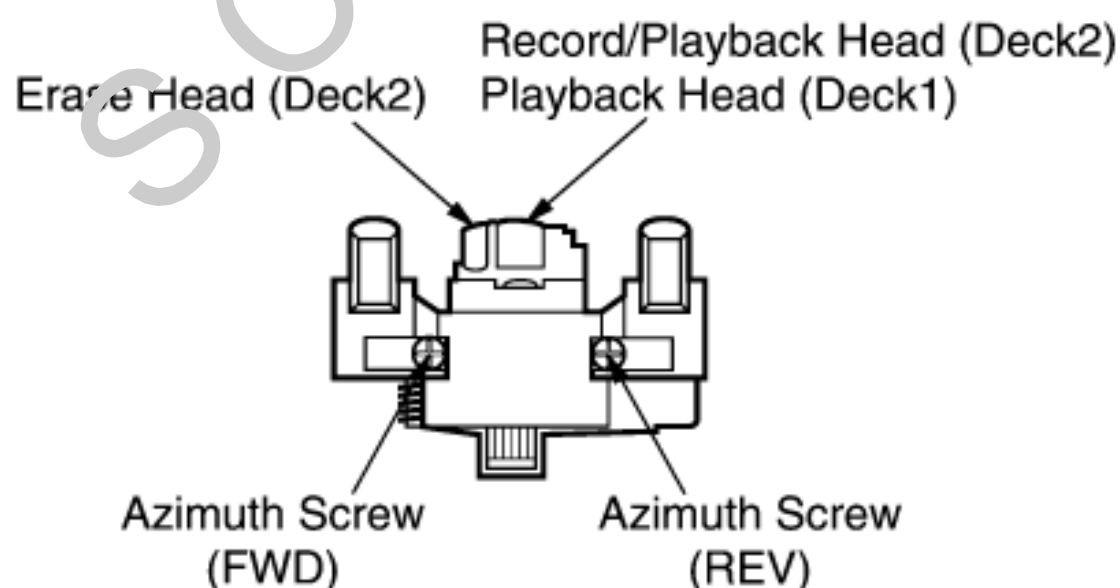

Fig. 13-2.



@

[TOP](#) [PREVIOUS](#) [NEXT](#)

13.4 Tape speed adjustment/(Deck 1/2)

[TOP](#) [PREVIOUS](#) [NEXT](#)

Note:

When connecting the unit to other system components for test, short the section between the test point [TP604](#) and [TP609](#) and turn on the entire system. (The unit is set to the TEST mode, and either Deck 1 or Deck 2 indicator will blink.)

Normal speed (Standard value: 3000 ± 45 Hz)

1. Connect the measuring instrument as shown in [Fig. 13-3](#).
2. Playback the middle portion of test tape. (QZZCWAT)
3. Adjust [VR801](#) (Deck 1) and [VR803](#) (Deck 2) for output value shown below. (For adjustment point, refer to [Fig. 13-11](#).)

Adjustment target: 3000 ± 15 Hz (Normal speed)

Standard value: 3000 ± 45 Hz (Normal speed)

Fig. 13-3.

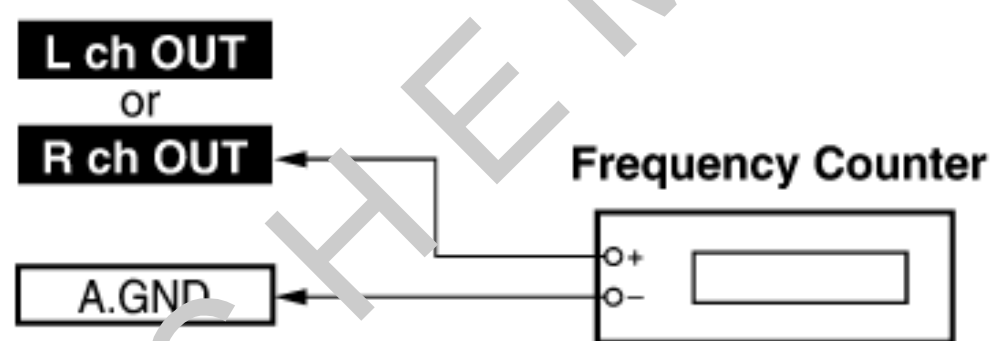

Note:

When the unit is finished for adjusting, disconnect the short section between [TP604](#) and [TP609](#) .

@

[TOP](#) [PREVIOUS](#) [NEXT](#)

14.1.1 Connection Diagram Between the Mechanism Ass'y and Power Supply/(MOTOR and Plunger)

[TOP PREVIOUS NEXT](#)

Fig. 14-1.

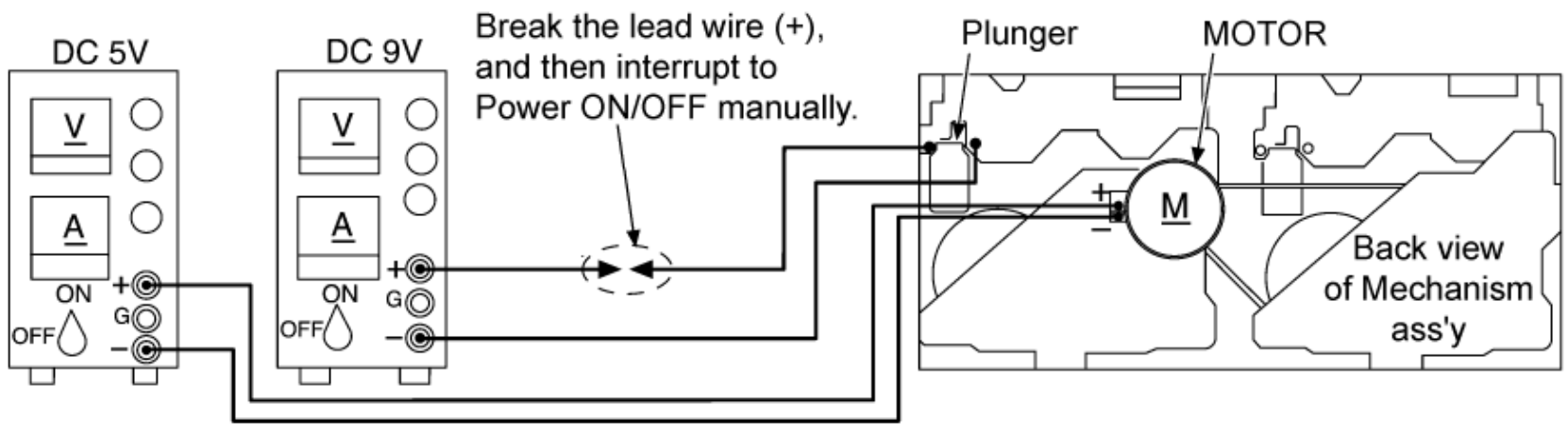

@

[TOP PREVIOUS NEXT](#)

SCHEMA 99

14.1.2 Detail View of EJECT Lever /(EJECT lever fixed by rubber band, Plunger rib operation)

[TOP](#) [PREVIOUS](#) [NEXT](#)

Fig. 14-2.

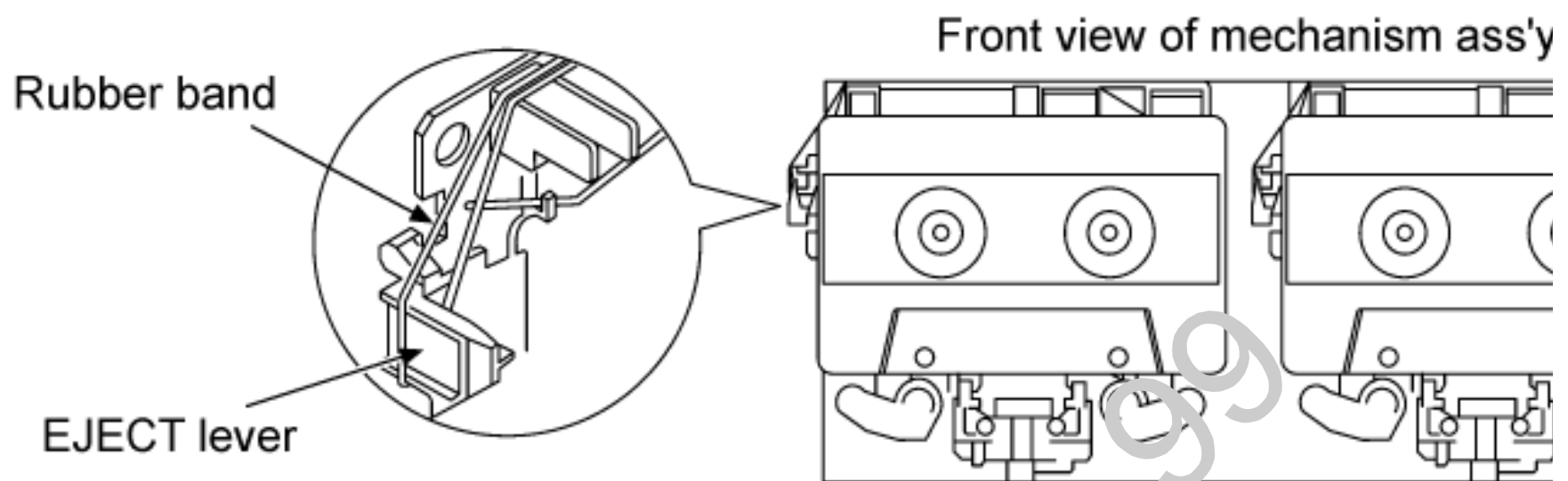

@

[TOP](#) [PREVIOUS](#) [NEXT](#)

A MAIN CIRCUIT

→ : POSITIVE VOLTAGE LINE ⇨ : RECORDING SIGNAL LINE ⇩ : PLAYBACK SIGNAL LINE

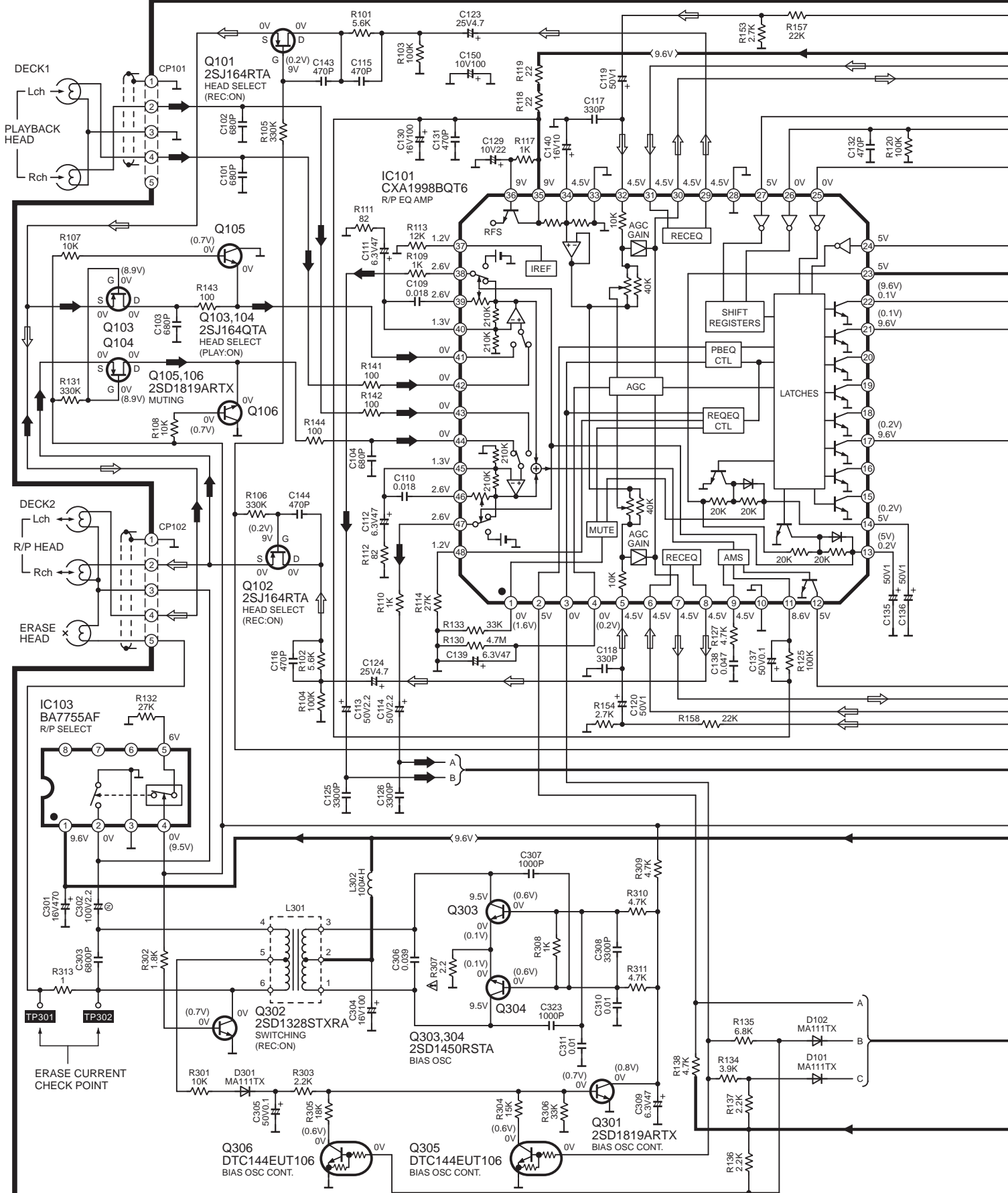

➔ : POSITIVE VOLTAGE LINE ➞ : RECORDING SIGNAL LINE ➡ : PLAYBACK SIGNAL LINE

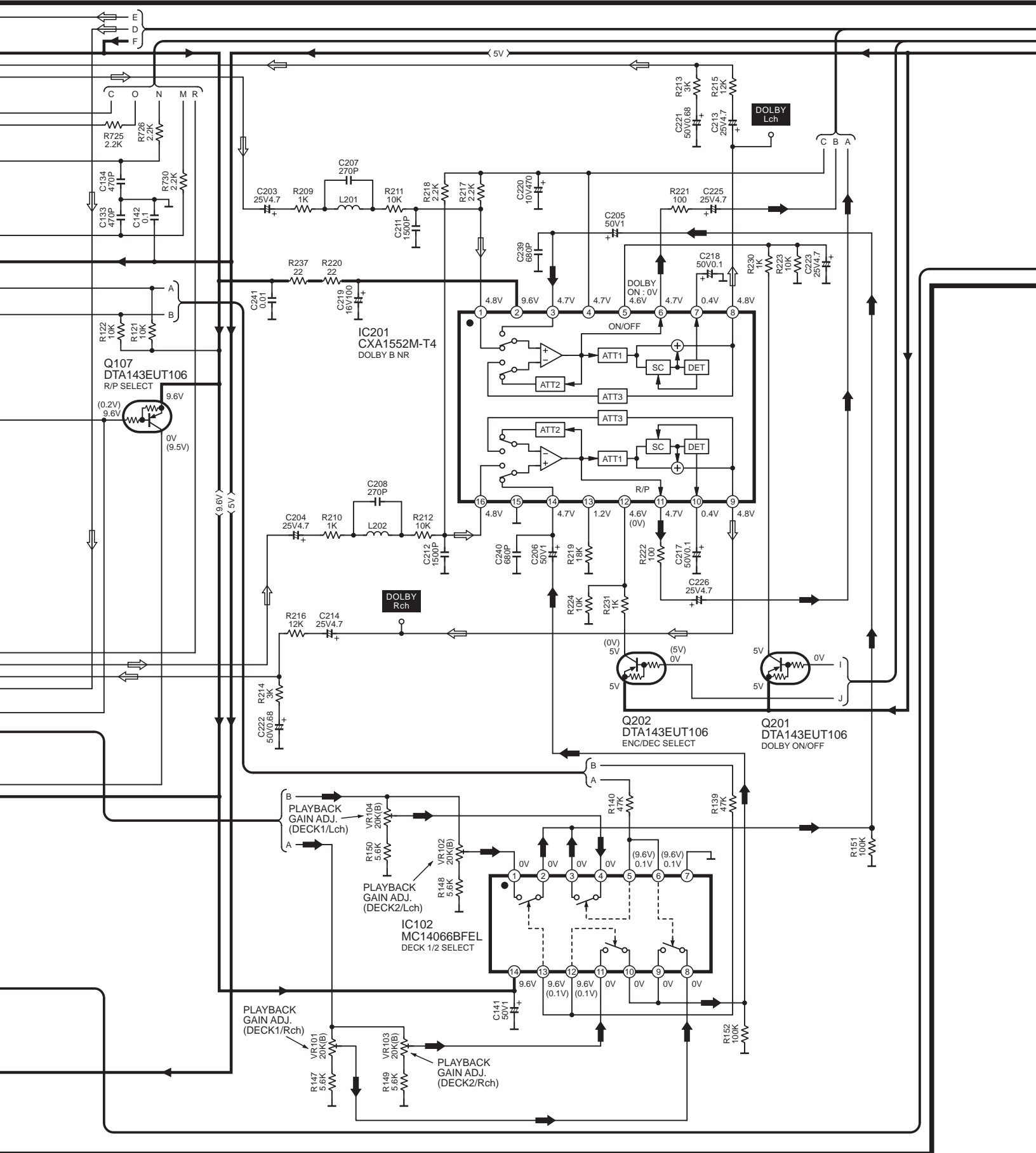

A MAIN CIRCUIT

→ : POSITIVE VOLTAGE LINE

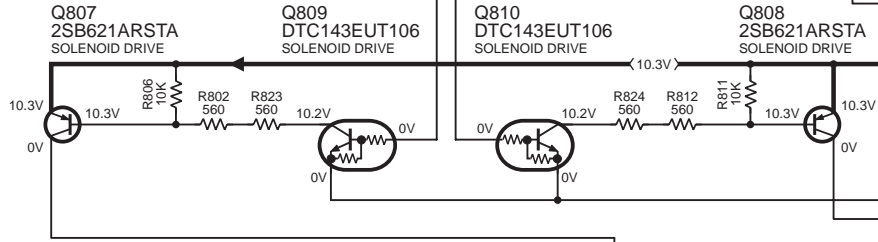

B MECHANISM CIRCUIT (DECK1)

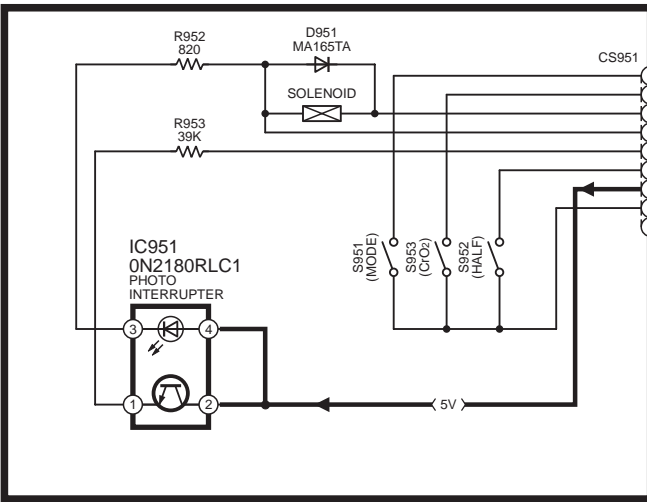

C MECHANISM CIRCUIT (DECK2)

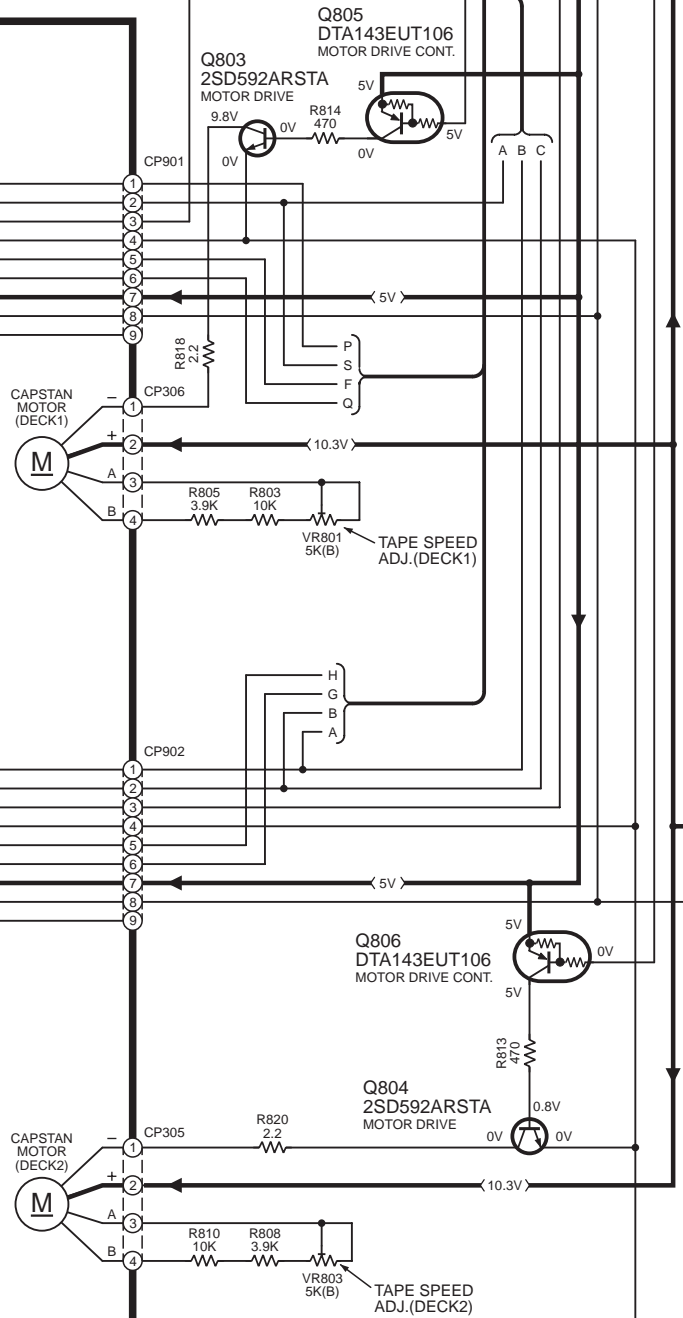
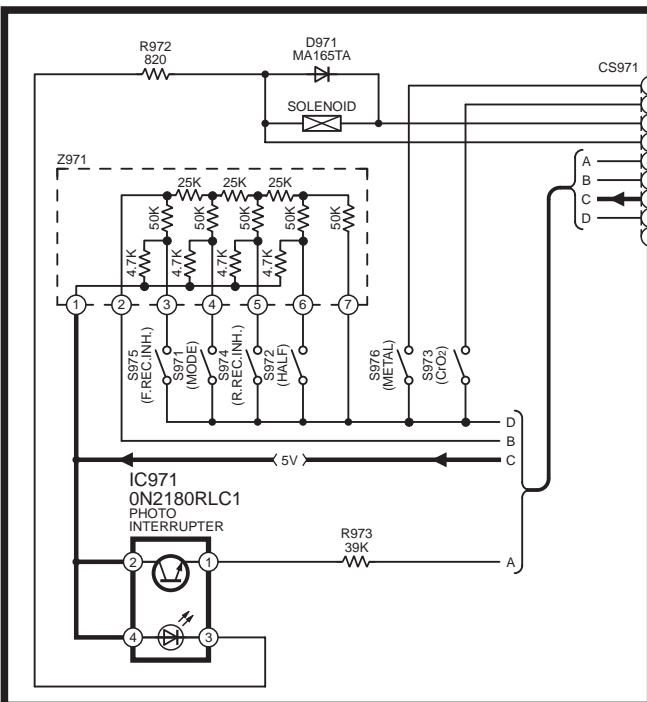

→ : POSITIVE VOLTAGE LINE ⇨ : RECORDING SIGNAL LINE ⇩ : PLAYBACK SIGNAL LINE

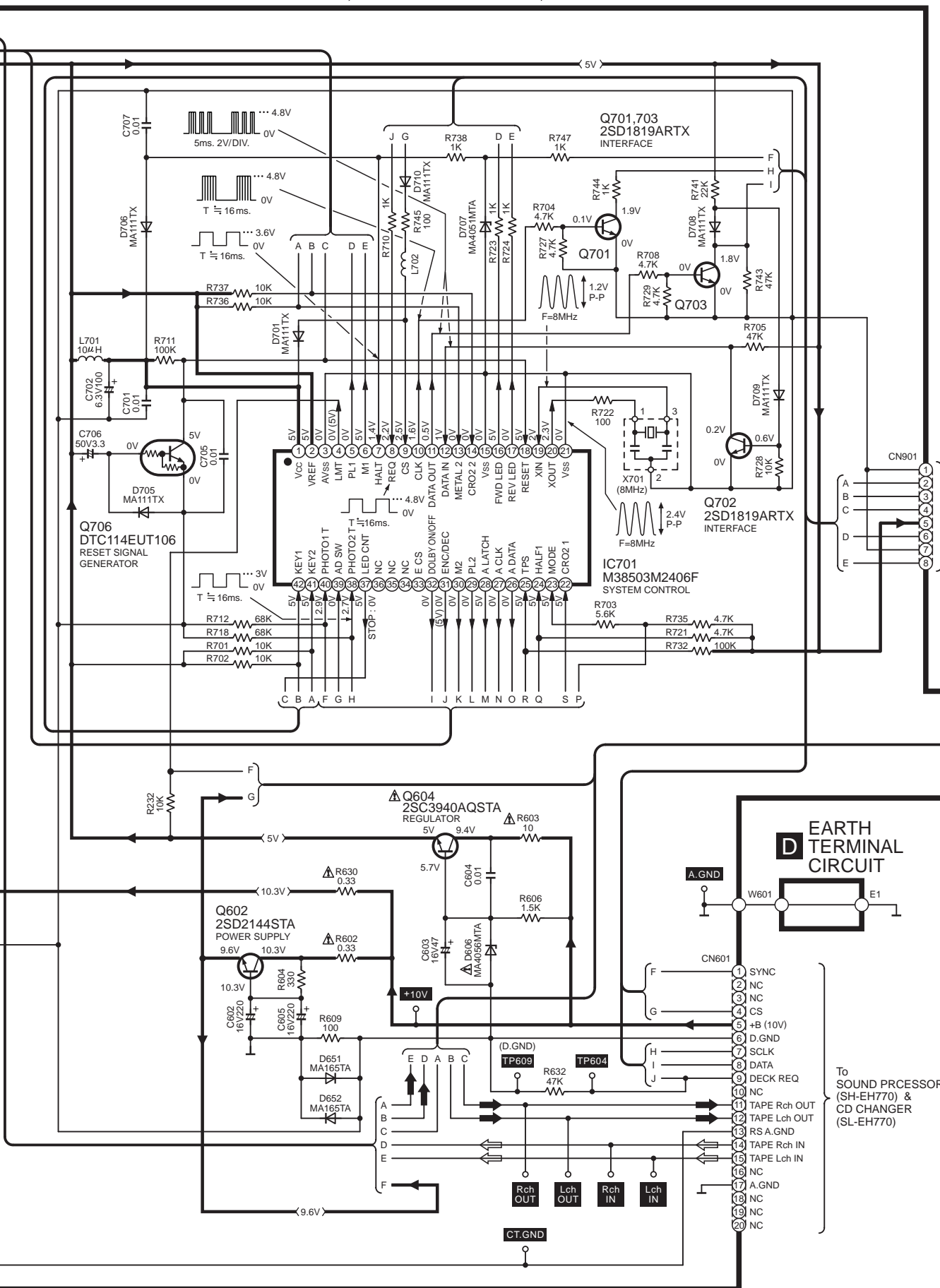

D EARTH TERMINAL CIRCUIT

- A.GND
 W601
 E1
 CN601
 1 SYNC
 2 NC
 3 NC
 4 CS
 5 +B (10V)
 6 D.GND
 7 SCLK
 8 DATA
 9 DECK REQ
 10 NC
 11 TAPE Rch OUT
 12 TAPE Lch OUT
 13 RS A.GND
 14 TAPE Rch IN
 15 TAPE Lch IN
 16 NC
 17 A.GND
 18 NC
 19 NC
 20 NC

To SOUND PROCESSOR (SH-EH770) & CD CHANGER (SL-EH770)

Rch OUT
Lch OUT
Rch IN
Lch IN

CT.GND

E OPERATION CIRCUIT

→ : POSITIVE VOLTAGE LINE
 ⇨ : PLAYBACK SIGNAL LINE

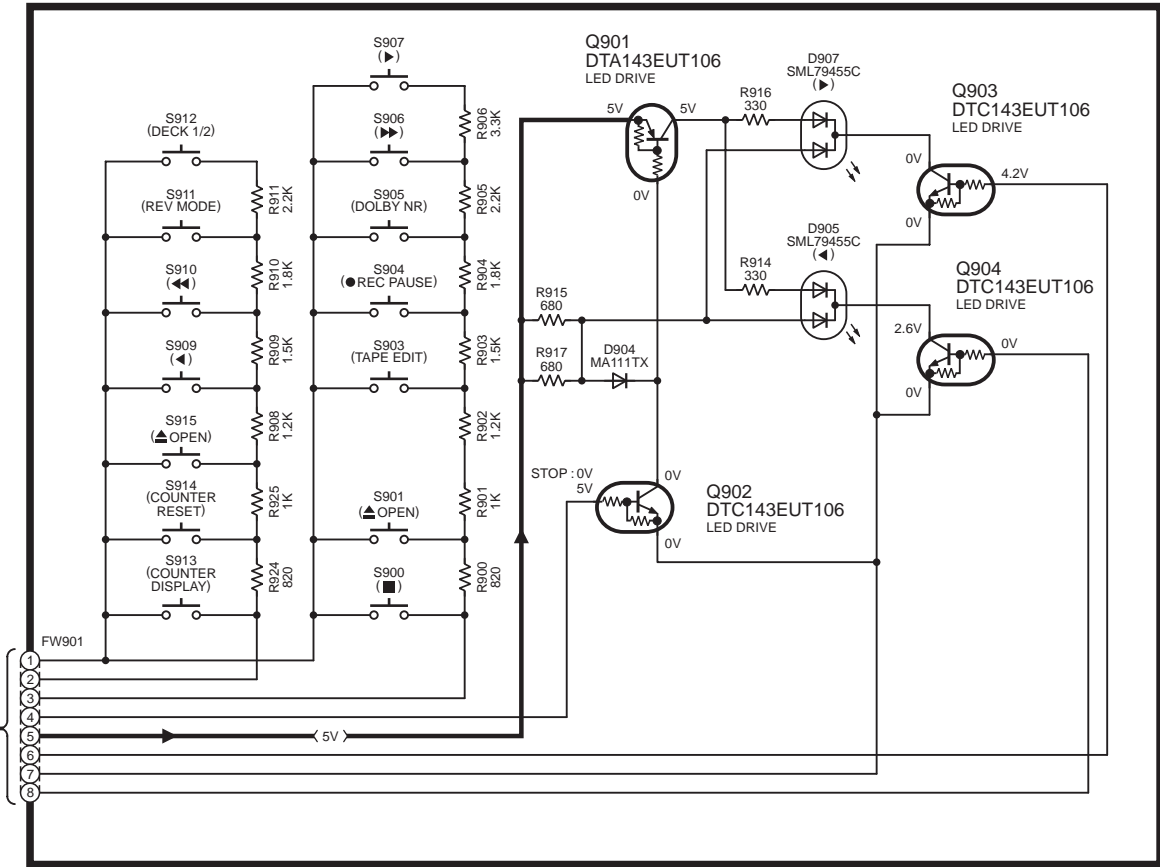

A MAIN CIRCUIT

