

Technics

Stereo cassette deck
RS-TR474/RS-TR373

Operating Instructions



The photograph shows the RS-TR474 model.

Note:

The "EB" indication shown on the packing case indicates United Kingdom.

Before connecting, operating or adjusting this product, please read these instructions completely.

E EB GC GN

RQT2237-B

Dear Customer

Thank you for purchasing this Technics product. For optimum performance and safety, please read these instructions carefully.

These operating instructions are applicable to the RS-TR474 and RS-TR373 models.

These operating instructions, however, fundamentally explain the operation of RS-TR474 model.

(For areas except United Kingdom, Europe, Australia and N.Z.)

CAUTION:

The AC voltage is different according to the area.

Be sure to set the proper voltage in your area before use.

(For details, please refer to the page 6.)

Table of Contents

Before use

Caution for AC mains lead (For United Kingdom)	3
Suggestions for safety	4
Front panel controls	5
Connections	6

Playback

Playback Basic play	7
Reverse function	8
To listen through headphones RS-TR474 only	8
About the automatic-tape-select function	8
About the remote control function	8
About the Dolby noise-reduction system	8
About the Dolby HX-Pro headroom extension system RS-TR474 only	8
Series playback	9
Linear counter RS-TR474 only	9
To reset the linear counter	9
Tape counter RS-TR373 only	10
To reset the tape counter	10
To fast-forward or rewind the tape	10
To find the beginning of a program (TPS function) RS-TR474 only	11

Recording

Recording (Deck 2 only)	12
About the ATC function RS-TR474 only	14
To make a silent interval	15
To make a 4-second silent interval	15
To make a silent interval more than 4 seconds	15
To erase recorded sound	15
Tape-to-tape recording	16
To record selected tracks	17
To cut unwanted parts during recording	17

Reference

Concerning cassette tapes	18
Maintenance	19
Technical specifications	19
Troubleshooting guide	Back cover

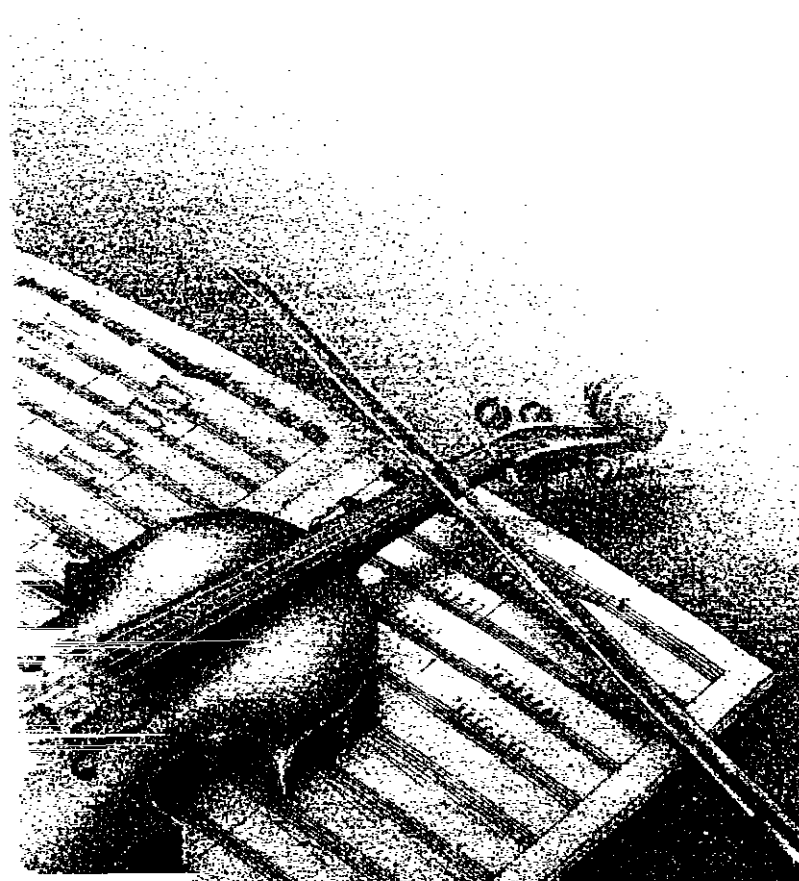

Caution for AC mains lead



(For United Kingdom)

("EB" area code model only)

For your safety, please read the following text carefully.

This appliance is supplied with a moulded three pin mains plug for your safety and convenience.

A 5-ampere fuse is fitted in this plug.

Should the fuse need to be replaced please ensure that the replacement fuse has a rating of 5-ampere and that it is approved by ASTA or BSI to BS1362. Check for the ASTA mark  or the BSI mark  on the body of the fuse.

If the plug contains a removable fuse cover you must ensure that it is refitted when the fuse is replaced.

If you lose the fuse cover the plug must not be used until a replacement cover is obtained.

A replacement fuse cover can be purchased from your local dealer.

CAUTION!

IF THE FITTED MOULDED PLUG IS UNSUITABLE FOR THE SOCKET OUTLET IN YOUR HOME THEN THE FUSE SHOULD BE REMOVED AND THE PLUG CUT OFF AND DISPOSED OF SAFELY.

THERE IS A DANGER OF SEVERE ELECTRICAL SHOCK IF THE CUT OFF PLUG IS INSERTED INTO ANY 13-AMPERE SOCKET.

If a new plug is to be fitted please observe the wiring code as shown below.

If in any doubt please consult a qualified electrician.

IMPORTANT

The wires in this mains lead are coloured in accordance with the following code:

Blue: Neutral

Brown: Live

As the colours of the wires in the mains lead of this appliance may not correspond with the coloured markings identifying the terminals in your plug, proceed as follows:

The wire which is coloured BLUE must be connected to the terminal in the plug which is marked with the letter N or coloured BLACK.

The wire which is coloured BROWN must be connected to the terminal in the plug which is marked with the letter L or coloured RED.

Under no circumstances should either of these wires be connected to the earth terminal of the three pin plug, marked with the letter E or the Earth Symbol .

Before use

Remove the connector cover as follows.

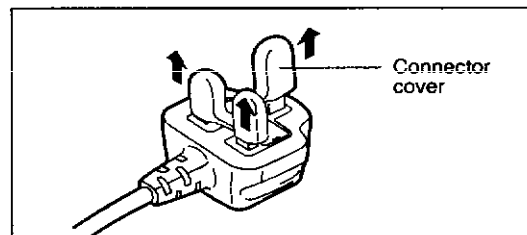

How to replace the fuse

1. Remove the fuse cover with a screwdriver.

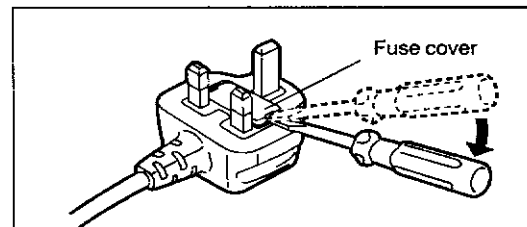

2. Replace the fuse and attach the fuse cover.

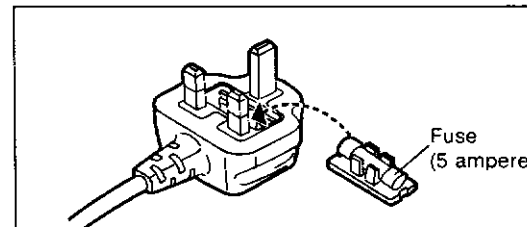

Suggestions for safety

Placement

Avoid placing the unit in areas of:

- direct sunlight
- high temperature
- high humidity
- excessive vibration
- uneven surfaces. (Place the unit on a flat level surface).

Such conditions might damage the cabinet and/or other component parts and thereby shorten the unit's service life.

Ventilation

- Place the unit in a well ventilated position at least 10 cms away from wall surfaces etc.
- Ensure that curtains and similar materials do not obstruct the ventilation holes.

Stacking

Never place heavy items on top of the unit or the power cord.

Voltage

- It is very dangerous to use an AC power source of high voltage such as for an air conditioner.
A fire might be caused by such a connection.
- A DC power source can not be used.
Be sure to check the power source carefully, especially on a ship or other place where DC is used.

Power cord protection

- Avoid cuts, scratches or poor connection of the AC mains cord, as this may result in fire or electric shock hazard.
Excessive bending, pulling or slicing of the cord should also be avoided.
- Do not pull on the cord when you are disconnecting the power, as this could cause an electric shock. Grasp the plug firmly when you disconnect the power supply.
- Never touch the plug with wet hands or a serious electric shock could result.

Foreign materials

- Ensure that no foreign objects, such as needles, coins, screwdrivers etc, accidentally fall into the unit or through the ventilation holes.
Otherwise, a serious electric shock or malfunction could occur.
- Be extremely careful about spilling water or liquid on/into the unit, as a fire or electric shock could occur.
(Disconnect the power plug and contact your dealer immediately if this occurs.)
- Avoid spraying insecticides onto the unit as they contain flammable gases which can be ignited
- Insecticides, alcohol, paint thinner and similar chemicals should never be used to clean the unit as they can cause flaking or cloudiness to the cabinet finish.

Maintenance (See page 19.)

Clean the cabinet, panel and controls with a soft cloth lightly moistened with mild detergent solution.

Do not use any type of abrasive pad, scouring powder or solvent such as alcohol or benzine.

Service

- Never attempt to repair, disassemble or reconstruct the unit if there seems to be a problem.
A serious electric shock could result if you ignore this precautionary measure.
- If a problem occurs during operation (the sound is interrupted, indicators fail to illuminate, smoke is detected, etc) contact your dealer or Authorised Service Center immediately.
- Disconnect the power supply if the unit will not be used for a long time. Otherwise the operation life could be shortened.

Front panel controls

When any of the numbers indicated below is repeated more than once (for example, ②), the number indicated on the left is the control for Deck 1 and that indicated on the right is for Deck 2.

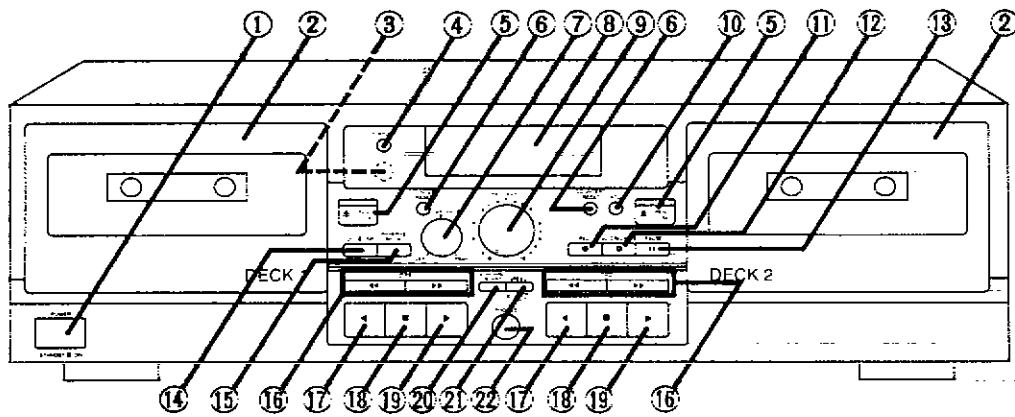

No.	Name	Ref. page
①	Power "STANDBY $\text{\textcircled{P}}$ /ON" switch (POWER, STANDBY $\text{\textcircled{P}}$ /ON)	7
	Press to switch the unit from on to standby mode or vice versa. In standby mode, the unit is still consuming a small amount of power.	
②	Cassette holder	—
③	Remote control signal receptor	—
	(Refer to "About the remote control function" on page 8.)	
④	"STANDBY" indicator (STANDBY)	—
	When the unit is connected to the AC mains supply, this indicator lights up in standby mode and goes out when the unit is turned on.	
⑤	Open/close button (\blacktriangle OPEN/CLOSE)	7
⑥	Counter reset button (COUNTER RESET)	9,10
⑦	Recording-balance control (BALANCE)	12
	RS-TR474 only	
⑧	Display	—
⑨	Recording-level control (REC LEVEL)	13
⑩	Auto tape calibration button (ATC) RS-TR474 only	12
⑪	Record button (\bullet REC)	12
⑫	Automatic-record-muting button ($\text{\textcircled{O}}$ AUTO REC MUTE)	15

No.	Name	Ref. page
⑬	Pause button ($\text{\textcircled{ }}$ PAUSE)	7
⑭	Dolby noise-reduction button (DOLBY NR)	7
⑮	Reverse-mode select button (REVERSE MODE)	7,8
⑯	For RS-TR474 Rewind/fast-forward search buttons ($\text{\textcircled{<<}}/\text{\textcircled{>>}}$ TPS)	10,11
	For RS-TR373 Rewind/fast-forward buttons ($\text{\textcircled{<<}}/\text{\textcircled{>>}}$)	10
⑰	Reverse-side playback button ($\text{\textcircled{<}}$)	7
⑱	Stop button ($\text{\textcircled{■}}$)	7
⑲	Forward-side playback button ($\text{\textcircled{>}}$)	7
⑳	Synchro-start button (SYNCHRO START)	16
㉑	Tape-to-tape recording-speed button (SPEED)	16
㉒	Headphones Jack (PHONES)	8
	RS-TR474 only	

Connections

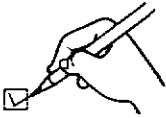

Please check and identify the supplied accessories

- | | | |
|---|---|--|
| <input type="checkbox"/> AC power supply cord
(For United Kingdom) 1 | <input type="checkbox"/> Stereo connection cables 2 | <input type="checkbox"/> Power plug adaptor 1
(Not supplied for United Kingdom, Europe, Australia and N.Z.) |
| (For Australia and N.Z.) | (For others) | |
-
- | | | | | |
|-----------|-------------|--------------|-------------|-------------|
| | | | | |
| (VJA0733) | (RJA0036-K) | (RJA0019-2K) | (SJP2249-6) | (SJP5213-2) |

Before making connections, make sure that the power to this unit and all other system components is turned off.

Note

- Avoid letting the cables touch each other as much as possible, otherwise noise will be generated.
- Although the figure below shows the AC power supply cord being connected to a household AC outlet, if the amplifier (or receiver) is equipped with an AC outlet, connect the cord to that outlet.

Placement hints

If this unit is placed near a receiver or a tuner, a "hum" noise may be heard during tape playback, recording, or AM reception of the receiver or the tuner.

If this occurs, leave as much space as possible between the units, or place them where there is the least amount of "hum".

For United Kingdom only
BE SURE TO READ THE CAUTION FOR AC POWER SUPPLY CORD ON PAGE 3 BEFORE THE FOLLOWING CONNECTIONS.

(For areas except United Kingdom, Europe, Australia and N.Z.)

Set the voltage selector to the voltage setting for the area in which the unit will be used.

[Use a minus (-) screwdriver]

Note

If the power supply in your area is 117 V or 120 V, set to the "127 V" position.

Note that this unit will be seriously damaged if this setting is not made correctly.

If the power plug will not fit your socket, use the power plug adaptor (included).

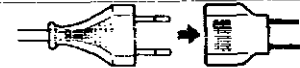

(For areas except Australia and N.Z.)

Insertion of Connector

Even when the connector is perfectly inserted, depending on the type of inlet used, the front part of the connector may jut out as shown in the drawing.

However there is no problem using the unit.

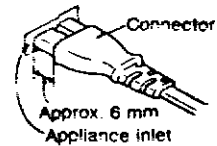

Connect this cord after all other cables and cords are connected.

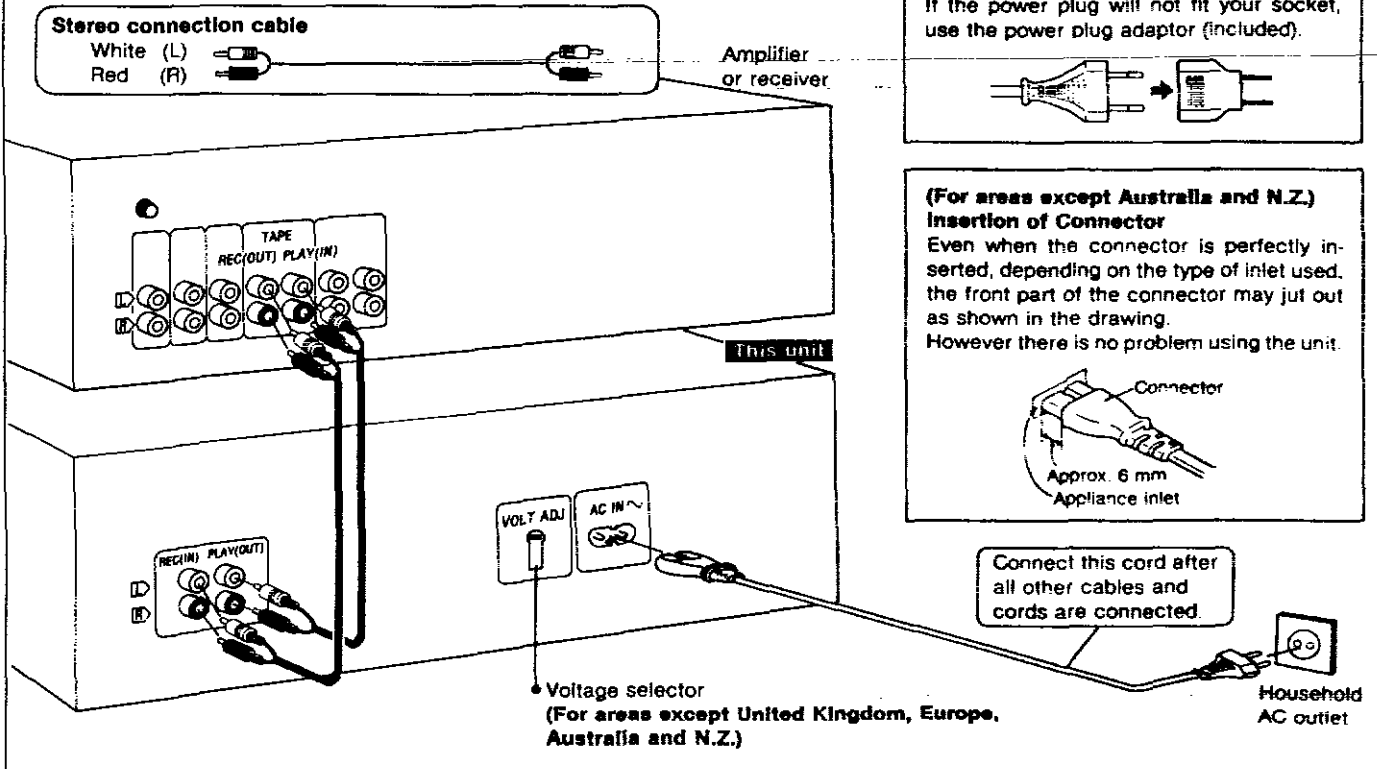

Basic play

Either normal, CrO₂ or metal type cassettes can be used.

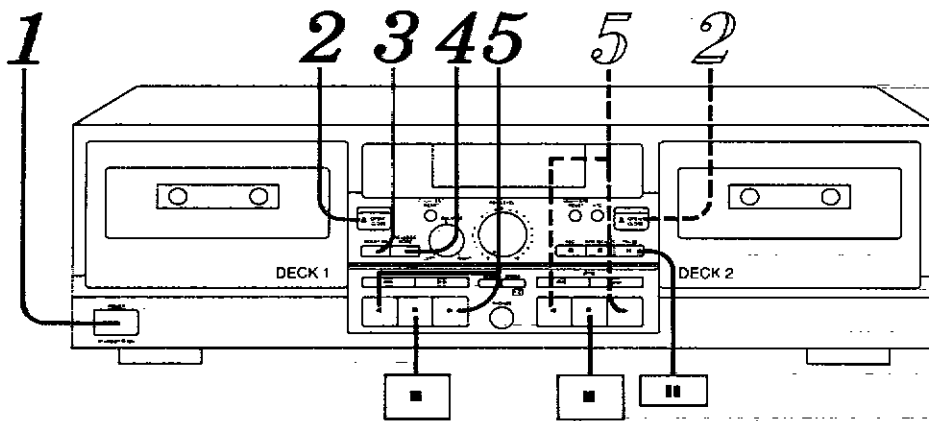

The procedures described below are an example of playback on Deck 1.

1 **POWER** **Press POWER.**
(The unit will switch on.)

2 **OPEN/CLOSE** **Press OPEN/CLOSE, and then insert the cassette tape.**
Press again to close the cassette holder.

Forward side Reverse side

Tape opening facing downward.

When the cassette holder is open, pressing ◀▶, ◀◀ or ▶▶ will close the holder and begin the desired function.

3 **DOLBY NR** **Press DOLBY NR to select the appropriate noise-reduction system.**

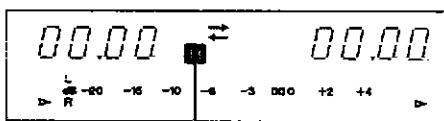

Each time the button is pressed, the indicators will change in the order: **B** → **C** → off.

Select the same type as that used for recording. When playing back a tape which was not recorded using a Dolby NR system, press so that the indicators go off.

4 **REVERSE MODE** **Press REVERSE MODE to select the appropriate reverse mode.**



Each time the button is pressed, the Indicator will change in the order:

→ : One side only.
↻ : Both sides repeatedly (up to 8 times).
∞ : Both sides, once only.
(Refer to page 8.)

5 **Press ▶ or ◀.**
(Playback will begin.)
▶ : To begin from the forward side.
◀ : To begin from the reverse side.



Illuminates Indicates the side being played.

To play back on Deck 2, in steps 2 and 5 above, press the buttons (2 and 5) for Deck 2.

To temporarily stop playback (Deck 2 only)

Press ||.
The "PLAY" indicator will flash.
Press once again to resume playback.

To stop playback
Press ■.



Playback (continued)

Reverse function

The reverse function on this unit has three modes (→, ↺, ↻). Read the descriptions below and select the mode as desired. (Refer to step 4 on page 7.)

Mode	Tape travel
→ ←	Only one side of the tape (either the forward side or the reverse side) will be played, and operation will automatically stop when playback has been completed.
↺	Both sides of the tape will be played repeatedly eight times, and then operation will automatically stop. (If playback is begun from the reverse side, the forward side will be played seven times.)
↻	When there is a tape in only one of the decks Both sides of the tape will be played once, and then operation will automatically stop. (If playback is begun from the reverse side, the forward side will not be played.) When there is a tape in each of the decks The forward and reverse sides of the tape in Deck 1 will be played, followed by the forward and reverse sides of the tape in Deck 2, and after this operation is repeated eight times, operation will automatically stop. (If playback is begun from Deck 2, the tape in Deck 1 will be played seven times.)

To listen through headphones

RS-TR474 only

Connect the headphones (not included) to the headphones jack.

Plug type: 1/4 inch phone plug, stereo type.

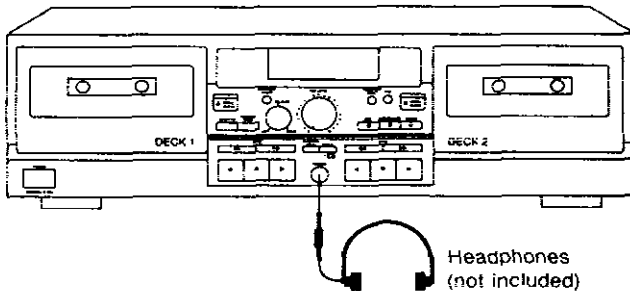

Note

Avoid listening for prolonged periods of time to prevent hearing damage.

About the automatic-tape-select function

This unit is equipped with the automatic-tape-select feature; it automatically detects the type of tape being used, and then makes the suitable adjustments of the bias and equalization accordingly.

About the remote control function

When connecting a Technics amplifier with the remote control transmitter to this unit, you can operate this unit using a remote control transmitter of the amplifier. (This may not be possible with some models.)

During operation from the remote control, the "R.C." indicator will light up.

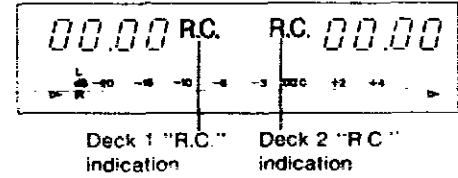

About the Dolby noise-reduction system

The Dolby noise-reduction system is designed to effectively reduce the annoying high-frequency "hissing" noise typical of cassette tapes. During recording, the system functions to increase the high-frequency sound level, the sound, and then, during playback, that same portion is weakened to bring it back to the previous level.

This unit includes two types of Dolby noise-reduction systems, the Dolby B NR-type and C NR-type.

Dolby B-type noise-reduction

Noise is reduced to about one-third.

Use this system when playing back tapes recorded by the Dolby B noise-reduction system, such as prerecorded music tapes, etc.

Dolby C-type noise-reduction

Noise is reduced to about one-tenth.

Use this system for the recording and playback of sound sources that have a wide dynamic range and good tone quality, such as FM broadcasts of live performances, etc., and for playing back such tapes.

About the Dolby HX-Pro headroom extension system **RS-TR474 only**

By functioning to improve the maximum output level of the tape's high-frequency range, this system permits recordings without a reduction in the level of the sound source's high-frequency range. In addition, by using the system in parallel with this unit's noise-reduction system, recording and playback with a greatly extended dynamic range is possible.

Dolby noise reduction and HX Pro headroom extension manufactured under license from Dolby Laboratories Licensing Corporation. HX Pro originated by Bang & Olufsen

"DOLBY", the double-D symbol  and "HX PRO" are trademarks of Dolby Laboratories Licensing Corporation

Series playback

Both sides of the tape in Deck 1 will be played, followed by both sides of the tape in Deck 2. (Repeated up to eight times.)

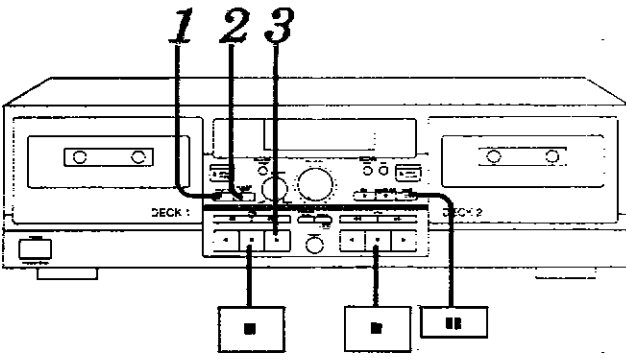

Preparation

Load the tapes to be played into Deck 1 and Deck 2. Note that for series playback it is not possible to select different types of Dolby NR for Deck 1 and Deck 2. It is recommended that you use two tapes which were recorded using the same type of Dolby NR (or both recorded without Dolby NR).

- 1** **DOLBY NR** Press **DOLBY NR** to select the appropriate noise-reduction system.
- 2** **REVERSE MODE** Press **REVERSE MODE** to select the "∞" mode.
- 3** Press **▶** on Deck 1. (Series playback will begin from the forward side of the tape in Deck 1.)

For your reference:

It is also possible to begin series playback from the reverse side of the tape in Deck 1 or from Deck 2. (Refer to the tape travel table on page 8.)

To temporarily stop playback (Deck 2 only)

Press II. Press once again to resume playback.

To stop playback

Press **■** for the deck which is playing.

Linear counter RS-TR474 only

The linear counter indicates the amount of tape travel as the approximate amount of elapsed time.

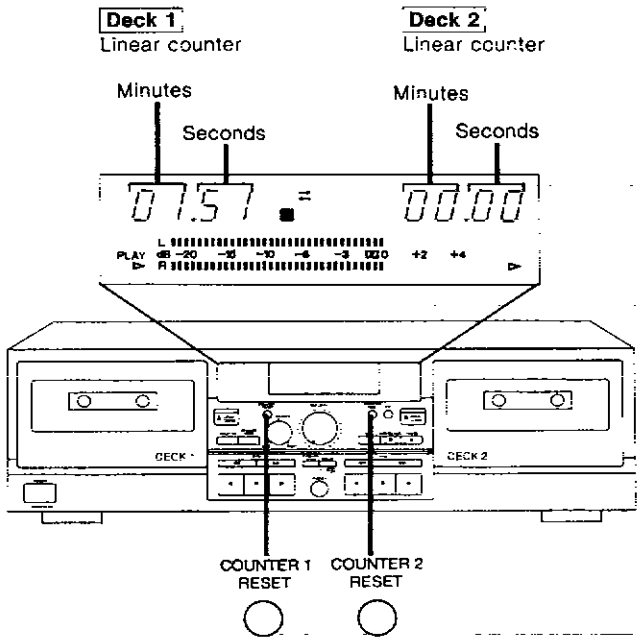

To reset the linear counter

Press COUNTER RESET. The linear counter indication will return to "00.00".

For your reference:

When the tape is travelling in the reverse direction, the value displayed on the linear counter will count down. After "00.00" is reached, the value will then start to become greater, but with a minus sign displayed (example: "-00.08").

Note

The linear counter is not a digital clock. The difference between the actual recording and playback time and the counter display may be anything up to several minutes.

Tape counter RS-TR373 only

The tape counter indicates the amount of tape travel as a numerical value based on the number of revolutions of the tape hub.

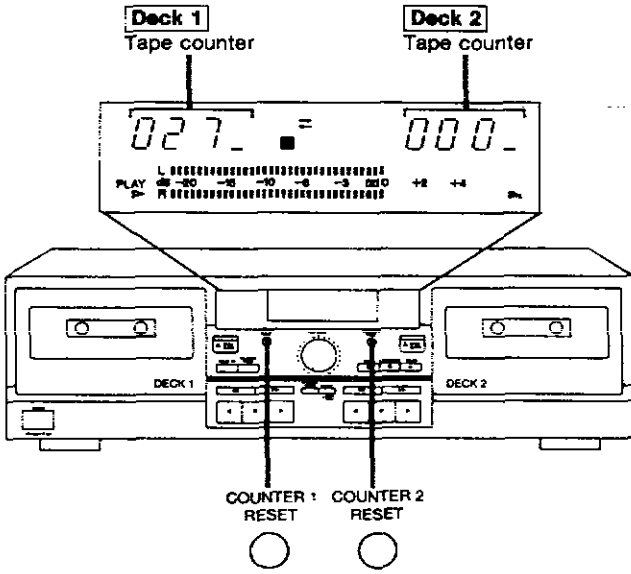

rewind the tape

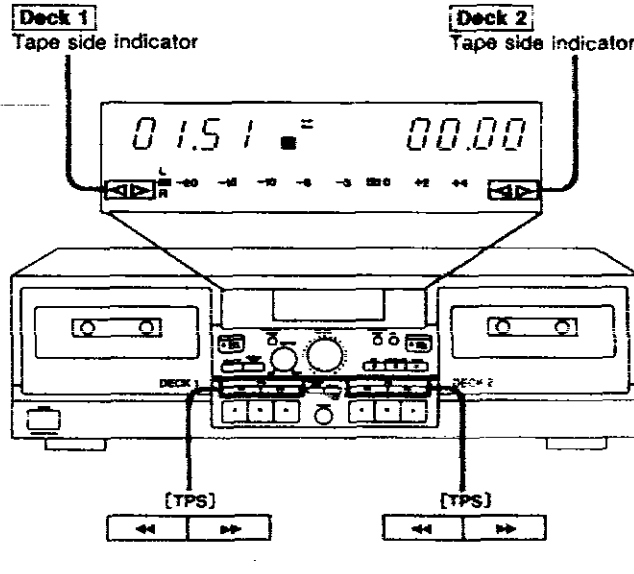

To reset the tape counter

Press COUNTER RESET.
The tape counter indication will return to "000".



For your reference:

When the tape is travelling in the reverse direction, the value displayed on the tape counter will count down. After "000" is reached, the display will switch to "999" and will then continue counting down.



Because this unit is capable of playing back both sides of the tape, the operation changes in accordance with the direction of the tape side indicator.

Tape side Indicator	Rewind	Fast-forward
▶	◀◀	▶▶
◀	▶▶	◀◀

• Cassette tapes in deck 1 and deck 2 can be advanced or rewound at the same time.

RS-TR474 only

High-speed tape transport

When fast-forwarding from near the beginning of the tape or when rewinding from near the end of the tape, the tape travel speed will be faster than that during normal fast-forwarding or rewind.

(During high-speed tape transport, the [H] indication will light up.)

This high-speed tape transport will also function during TPS.

(TPS: Tape Program Sensor)

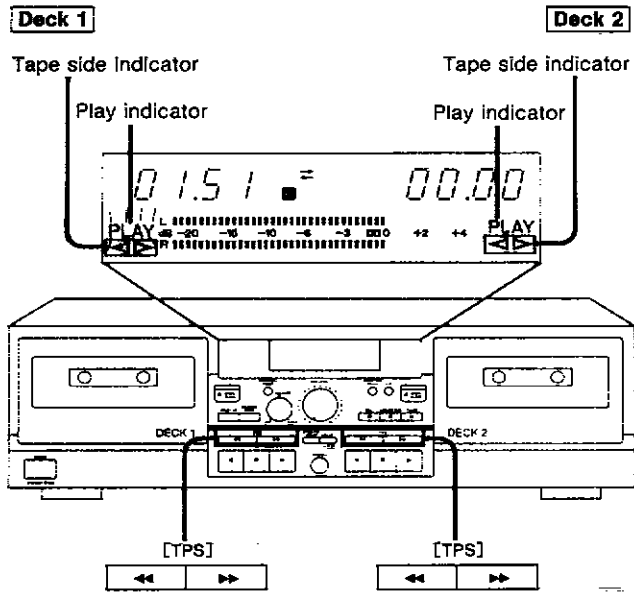

- During operation of the TPS function, the play indicator will flash quickly.
- To find the beginning of a track which is several tracks before or after the track currently being played, repeat the procedure until the desired track is found.
- If the reverse mode is set to "↺" or "↻", when the end of the tape is reached, operation will switch to the other side of the tape and the TPS function will continue to operate.

Note

Because the TPS function utilizes the blank spaces between tracks, it may not be able to function properly under the following conditions:

- When there is less than 4 seconds of silent interval between tracks
- When there are no completely silent intervals (such as when the tape has been recorded using a microphone)
- When there are especially low-level parts or silent parts inside a track (such as sometimes occurs in classical music)
- If the ◀◀ or ▶▶ button is pressed when less than 10 seconds has elapsed from the beginning of the track or there is less than 10 seconds remaining to the beginning of the next track
- If the tracks have been recorded with a fade-in (a gradual increase in the recording level) or a fade-out (a gradual decrease in the recording level)

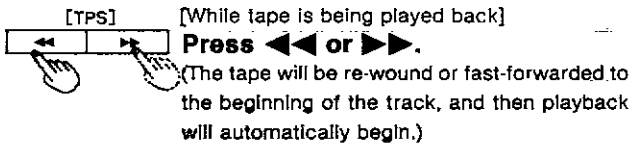

Because this unit is capable of playing back both sides of the tape, the operation changes in accordance with the direction of the tape side indicator.

Tape side indicator	Tape returns to the beginning of the track currently being played, and playback begins.	Playback begins from the beginning of the next track.
▶	◀◀	▶▶
◀	▶▶	◀◀

To return to the normal speed during high-speed tape transport

Press the ◀◀ or ▶▶ button corresponding to the current direction of tape travel.

Note

Depending on the amount of tape on the take-up and supply sides, the tape may not be transported at high-speed.

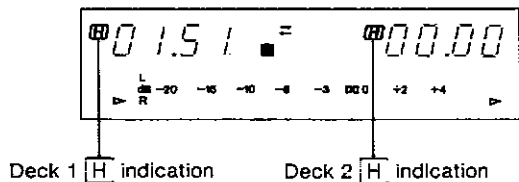

Recording (Deck Only)

Either normal, CrO₂ or metal type cassettes can be used.

RS TR474 only

This unit is equipped with an ATC function (refer to page 14) which automatically sets the optimum recording conditions to match the characteristics of the tape being used. It is recommended that you use this function when recording.

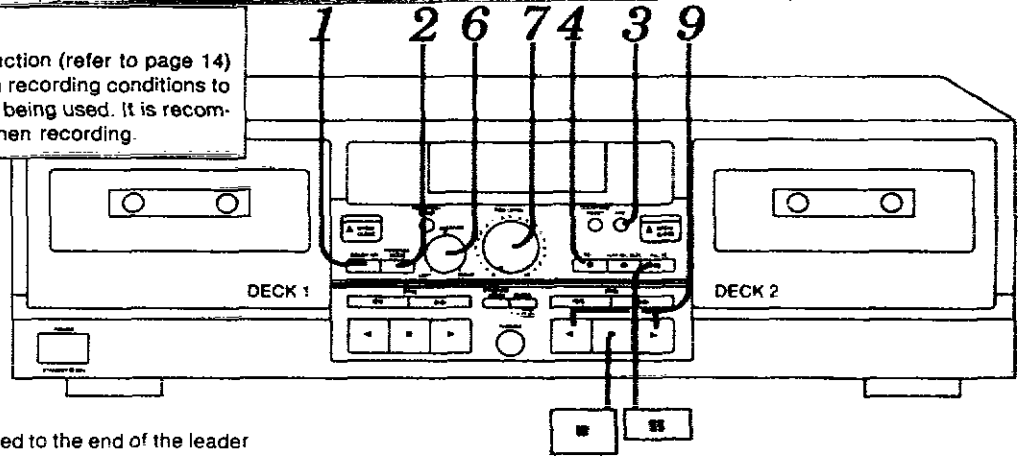

Preparation

1. Switch on the power.
2. Load a tape which has been advanced to the end of the leader tape (the transparent part at both ends of the tape) into Deck 2.

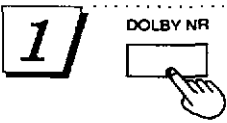

Press DOLBY NR to select the desired noise-reduction system. (Refer to the opposite page.)

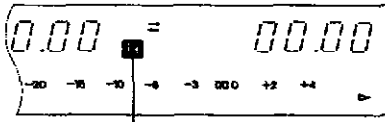

Each time the button is pressed, the indicator will change in the order:
B → **C** → off.

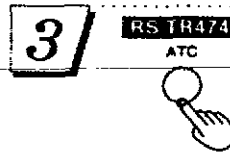

RS TR474 only

Press ATC.

Setting of the ATC (refer to page 14) will commence, and will be completed after approximately one minute. When the settings are complete, the tape will be returned to the position from which the ATC function began, and then the unit will enter the stop mode.



Indicates that ATC has been set.

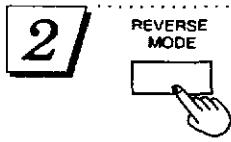

Press REVERSE MODE to select the desired reverse mode.



Each time the button is pressed, the indicator will change in the order:



→ : Only one side will be recorded, and then operation will automatically stop.

∞, ∞ : Both sides (the forward side first, and then the reverse side) will be recorded, and then operation will automatically stop.

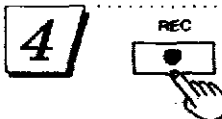

Press REC ●.

(The unit will be in the recording standby mode.)

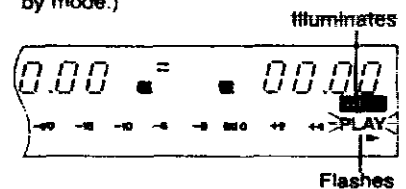

illuminates

Flashes



Play the source in order to adjust the recording sound.

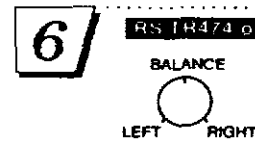

RS TR474 only

If necessary, adjust the BALANCE control to adjust the balance.

(Refer to the opposite page.)
 (The control should normally be set to the center position.)

7

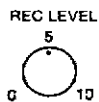

Use the REC LEVEL control to adjust the recording level. (Refer to the right side of this page.)

8

Stop play of the source.

9

Press ◀ or ▶ to begin recording, and play the source to be recorded.



▶: To begin recording from the forward side.
◀: To begin recording from the reverse side.

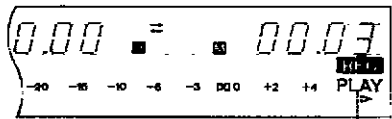

Illuminates

Note
When recording on both sides of the tape, be sure to press the ▶ button.

RS-TR474 only

When recording without using the ATC function, step 3 is unnecessary.

To temporarily stop recording



Press II.

Press once again to resume recording.

To stop recording



Press ■.

RS-TR474 only

To cancel the ATC settings

[While ATC settings are in progress]



Press ■.

[After ATC settings have been completed]



Press ATC.

If the M indicator begins to flash quickly while the ATC settings are in progress, it indicates that the settings cannot be made for one of the following reasons:

About the selection of the Dolby NR type

The Dolby NR effect can be obtained by using the same type of Dolby NR during both recording and playback. Refer to the following table when selecting the type (either B or C).

Type B	Use this type when the deck on which the tape will be played back is equipped with only type B Dolby NR.
Type C	Use this type when the deck on which the tape will be played back is equipped with type C Dolby NR. (for example, when this unit is also going to be used to play back the tape.)

(Refer to "About the Dolby noise-reduction system" on page 8.)

About the balance adjustment

RS-TR474 only

While playing a monaural source, adjust so that the left and right level indications on the level meter are the same.

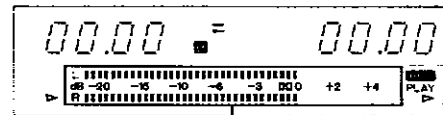

Level meter

About the recording level adjustment

If the recording level is too high, there will be distortion in the recorded sounds, and if it is too low, the hiss noise inherent to recording tapes will become noticeable.

In order to make high-quality recordings, use the REC LEVEL control to adjust so that highest values of the input level indicated by the level meter do not exceed the standard recording level (the number indicated in parentheses) for the tape being used.

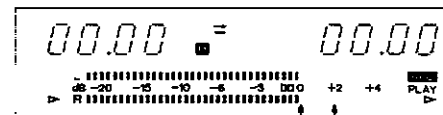

Normal or CrO₂ tape (0) Metal tape (+2)

- The tape has reached the leader tape.
- The tape is severely damaged.
- The cassette deck's heads are severely dirty.
- The tape is a non-standard type, such as a metal tape which has no tape type identification hole in the cassette.

Note



- If the cassette holder is opened after the ATC settings have been completed, the settings will be canceled.
- When making the ATC settings midway along a tape, provide a silent interval at least 2 seconds long after the last track prior to where the settings will begin.

About the ATC function

RS-TR474 only

The ATC (auto tape calibration) function records a test signal in order to automatically set the bias, equalizer and recording/playback level to the optimum recording conditions in accordance with the characteristics of the tape being used.

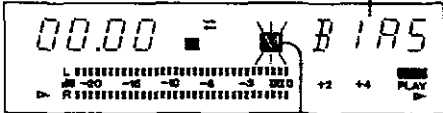
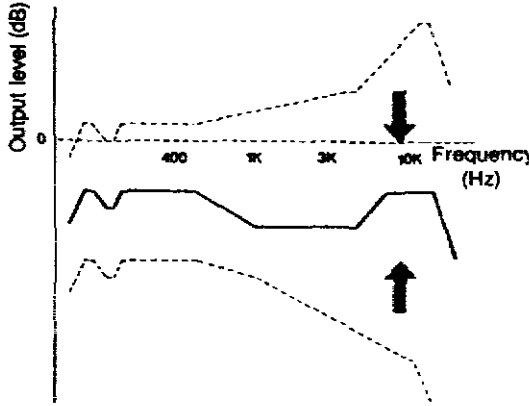
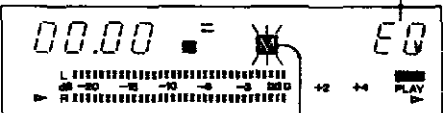
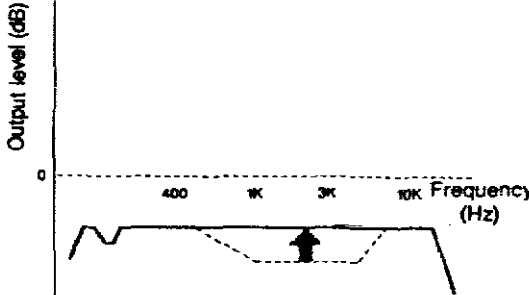
The table below shows the conditions of the display and the operation of the unit while the ATC settings are being made.

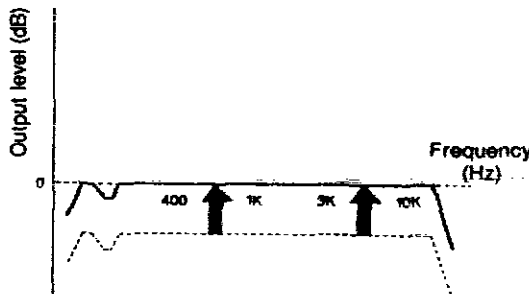
	Display	Unit operation
① Bias adjustment	<p>"BIAS" is displayed.</p>  <p>Flashes</p>	<p>The bias is adjusted so that the output level is the same at 400 Hz and at 10 kHz.</p> 
② Equalizer adjustment	<p>"EQ" is displayed.</p>  <p>Flashes</p>	 <p>The equalizer is adjusted so that the output level is the same at 400 Hz and at 3 kHz.</p>
③ Level adjustment	<p>"LEVL" is displayed.</p>  <p>Flashes</p>	 <p>The tape sensitivity is compensated so that the recording input level and the playback output level are the same.</p>

To make a silent interval

A silent interval of 4 seconds or more can be provided between tracks. This function is useful for playing back on decks which can skip to the beginning of tracks, and for cutting unwanted sound from commercials.

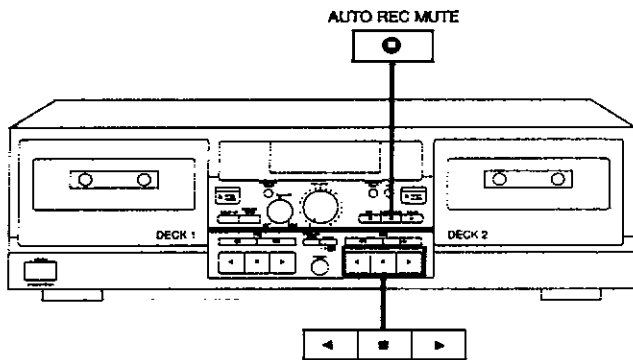

To make a 4-second silent interval

AUTO REC MUTE



Press **AUTO REC MUTE** momentarily while a recording is being made.

A 4-second silent interval will be recorded, and the unit will automatically be set to the recording standby mode.

To make a silent interval more than 4 seconds

AUTO REC MUTE



Press and hold **AUTO REC MUTE** for the necessary number of seconds while a recording is being made.

The unit will change to the recording standby mode when the button is released.

To resume recording

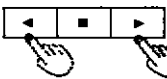

Press either ◀ or ▶, corresponding to the side of the tape side indicator which is lit.

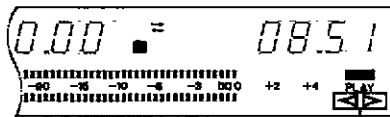

Tape side indicator

To erase recorded sound

When new recordings are made on a pre-recorded tape, all sounds recorded on that portion of the tape are automatically erased. To erase a tape without making a new recording, follow the steps below.

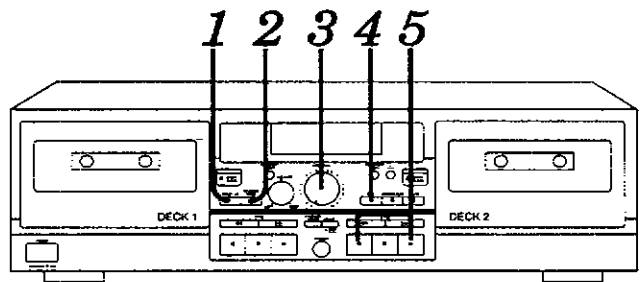

Preparation

Load the tape to be erased into Deck 2.

1

DOLBY NR

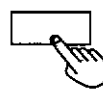

Press **DOLBY NR** so that the Dolby NR indicators ("B" and "C") are off. (Refer to page 12.)

2

REVERSE MODE

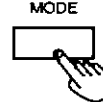

Press **REVERSE MODE** to select the desired reverse mode.

→ : To erase one side of the tape.
 ↻ : To erase both sides of the tape.

(Refer to page 12.)

3

REC LEVEL

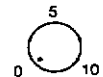

Set the **REC LEVEL** control to "0".

4

REC



Press **REC**.

(The unit will be in the recording standby mode.)

5

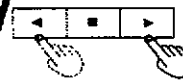

Press ◀ or ▶ to begin erasing the tape.

▶ : To erase the forward side of the tape.

◀ : To erase the reverse side of the tape.

Note

To erase both sides of the tape, be sure to press the ▶ button.

Tape-to-tape recording

Either normal, CrO₂ or metal type cassettes can be used.

Use Deck 2 to record the sound being played back on Deck 1.

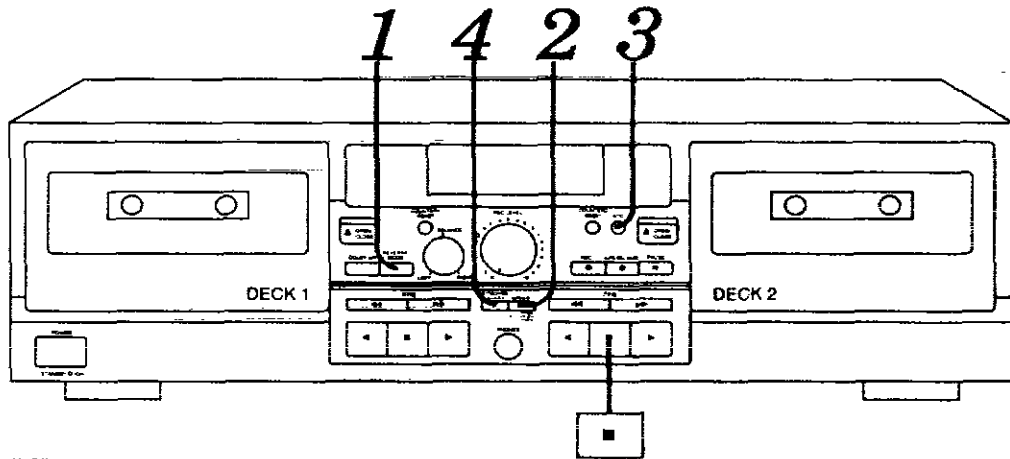

Preparation

1. Switch on the power.
2. Load tapes which have been advanced to the end of the leader tape into both decks.

Deck 1: For playback **Deck 2:** For recording

1 **REVERSE MODE** Press **REVERSE MODE** to select the desired reverse mode.

Each time the button is pressed, the indicator will change in the order:

→ → → ∞

- : Only one side of the tape will be recorded, and then operation will automatically stop.
- ∞ : Both sides of the tape (first the forward side and then the reverse side) will be recorded, and then operation will automatically stop. If the recording tape is longer than the playback tape, the playback tape will be played repeatedly as many as eight times until the recording tape is finished.
- ∞ : Both sides of the tape (first the forward side and then the reverse side) will be recorded once, and then operation will automatically stop.

2 **SPEED** Press **SPEED** to select the recording speed.

Each time the button is pressed, the indicators will change in the order:
x1 → x2 → off

- x1: Normal speed
- x2: Double speed

3 **RS TR474 only** **ATC** Press **ATC**.
(The ATC function will enter the stand-by mode.)

Flashes

4 **SYNCHRO START** Press **SYNCHRO START**.
For RS TR474 (ATC will begin, and when it is completed, recording will begin.)
For RS TR373 (The recording will begin.)

Note
To record on only one side of the tape, set the tape side indicators (< or >) on Deck 1 and Deck 2 in accordance with the tape sides to be played back and recorded.
To record on both sides of the tape, set the tape side indicators on both Deck 1 and Deck 2 to the forward side (>).

Note
In order to avoid operation errors later, be sure to switch OFF the SPEED button (the "x1" and "x2" indicator will go out) after the tape-to-tape recording has finished.

RS TR474 only When recording without using the ATC function, step 3 is unnecessary.

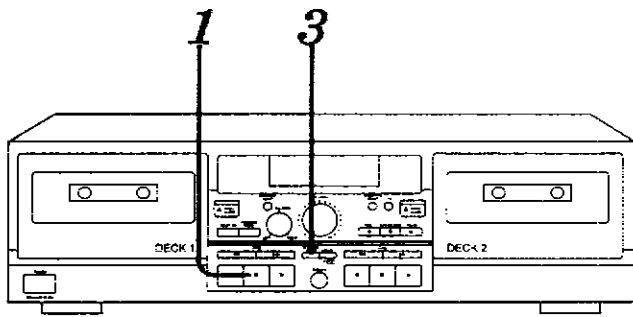

To record selected tracks

1 During recording, press ■ on Deck 1.
(Deck 1 will stop, and Deck 2 will record a 4-second silent interval and then enter the recording standby mode.)

2 Operate Deck 1 to find the track you wish to record.
It is also possible to change the playback tape at this time.
RS-TR474 only
The TPS function is useful for finding the beginning of the track.
(Refer to page 11.)

3 Press SYNCHRO START.
(Recording will resume.)

To stop recording

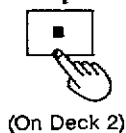

(On Deck 2)

Your attention is drawn to the fact that recording pre-recorded tapes or discs on other published or broadcast material may infringe copyright laws.

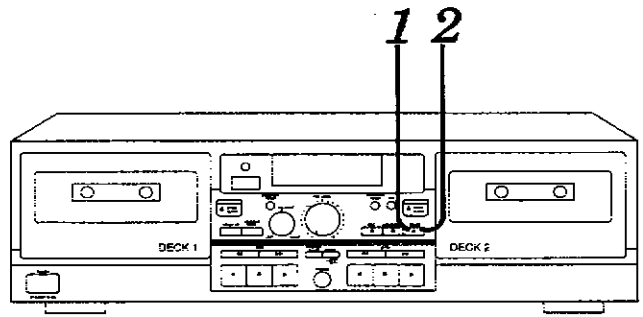

To cut unwanted parts during recording

1 Press ■ during recording.
(Deck 2, which was recording, will enter the pause mode, and Deck 1 will continue playback.)

2 [When Deck 1 reaches a part you wish to record]
Press ■.
(Deck 2 will resume recording.)

For your reference:

- The recording level and the Dolby effect will be recorded as they are on the tape being played back.
- Because the signal being recorded from Deck 1 onto Deck 2 does not pass through the amplifier, it is possible to change the setting of the amplifier's input selector during recording in order to listen to some other sound source.

Note

When recording with the recording speed set to double speed, noise interference may be recorded onto the tape if there is a television set nearby, so make the recording in a location separated from the television set or switch off the television set during recording.

Concerning cassette tapes

Selection of cassette tapes

Cassette tapes exceeding 90 minutes

These tapes are handy for their long playback and recording time but be careful about repeatedly stopping and starting, rewinding and fast forwarding these tapes in short intervals as they are thin, tend to stretch and may become entangled in the machine.

Fe-Cr tapes (TYPE III)

The high frequency range will be emphasized, and it will not be possible to obtain a flat frequency response.

Metal tape without detection holes in the cassette

Recordings will be very distorted. (However, there will be no problem with playback.)

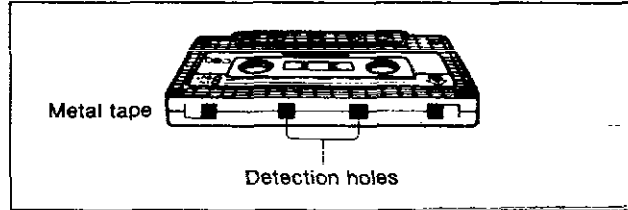

Erasure prevention

Remove the tab(s).

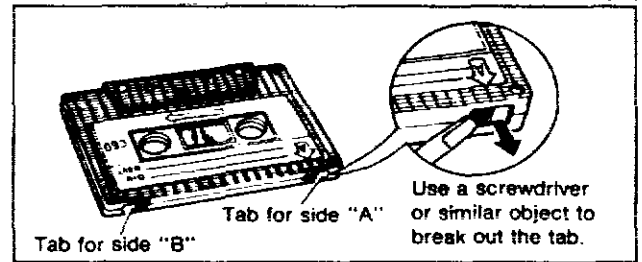

To re-record on a protected cassette

Cover the slot with adhesive tape.

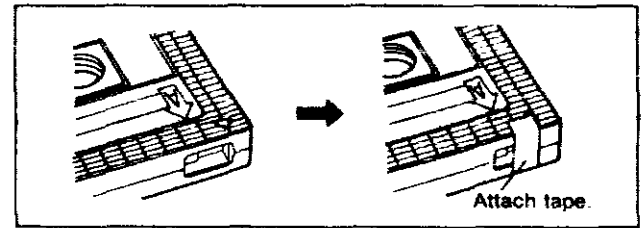

Tape slack

Tape slack may cause the tape to break.

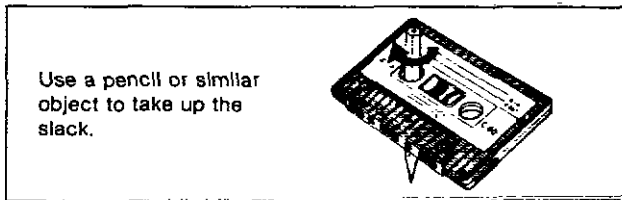

Tape storage

Tapes can be damaged if stored in places such as those described below.

- Where the temperature is high (95° F/35° C or higher) or where the humidity is high (80% or higher)
- Where there is a strong magnetic field (near a speaker, on top of a TV, etc.). Recording may become erased.
- in direct sunlight

Head care

To assure sound quality for recording and playback, be sure to clean the heads after approximately every 10 hours of use.

- 1) Press the open/close button to open the cassette holder.
 - 2) **Disconnect the AC power supply cord from the AC outlet.**
 - 3) Clean the heads, pinch roller and the capstan shaft with a cotton swab (or with a soft, lint-free cloth) slightly moistened with isopropyl alcohol.
- Do not use any solution other than alcohol for head cleaning.

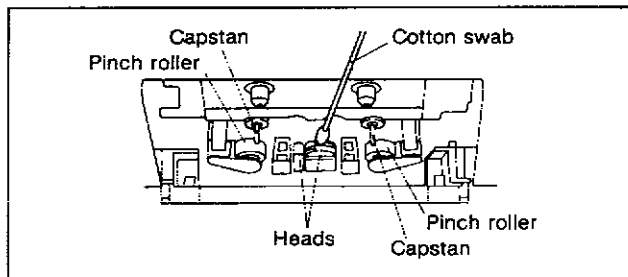

Head demagnetization

In order to maintain good sound quality during recording and playback, it is recommended that the head assembly be demagnetized if distortion or poor sound quality persists after cleaning the heads.

If the head assembly becomes magnetized, it could create noise in the recordings, loss of high-frequency response or erasure of valuable recordings.

Several types of head demagnetizers are available and may be purchased separately at local electronics supply stores. Follow the instructions that are supplied with the device.

Do not bring any type of metal objects or tools such as magnetic screwdrivers in contact with the head assembly.

Maintenance of external surfaces

To clean this unit, use a soft, dry cloth.

If the surfaces are extremely dirty, use a soft cloth, dipped into a soap-and-water solution or a weak detergent solution.

Wring the cloth well before wiping the unit.

Wipe once again with a soft, dry cloth.

Never use alcohol, paint thinner, benzene, nor a chemically treated cloth to clean this unit.

Such chemicals may damage the finish of your unit.

■ CASSETTE DECK SECTION

Deck system	Stereo cassette deck
Track system	4-track, 2-channel
Recording system	AC bias
Bias frequency	80 kHz
Erasing system	AC erase
Heads	
DECK 1	Playback head (Permalloy) × 1
DECK 2	Recording/Playback head (Permalloy) × 1 Erasing head (Double-gap ferrite) × 1
Motors	
DECK 1	Capstan drive (DC servo motor) × 1 Reel table drive (DC motor) × 1
DECK 2	Capstan drive (DC servo motor) × 1 Reel table drive (DC motor) × 1
Tape speed	4.8 cm/sec. (1-7/8 ips)
Wow and flutter	0.1% (WRMS) ±0.2% (DIN)
Fast forward and rewind times	
	[RS-TR474] Approx. 50 seconds with C-60 cassette tape
	[RS-TR373] Approx. 95 seconds with C-60 cassette tape
Frequency response (Dolby NR off)	
NORMAL	40 Hz - 15 kHz, ±3 dB 20 Hz - 16 kHz (DIN)
CrO₂	40 Hz - 15 kHz, ±3 dB 20 Hz - 16 kHz (DIN)
METAL	40 Hz - 16 kHz, ±3 dB 20 Hz - 17 kHz (DIN)
S/N (Signal level = max recording level, CrO₂ type tape)	
NR off	56 dB (A weighted)
Dolby B NR on	66 dB (A weighted)
Dolby C NR on	74 dB (A weighted)
Input sensitivity and impedance	
REC (IN)	100 mV/47 kΩ
Output voltage and impedance	
PLAY (OUT)	500 mV/500 Ω
HEADPHONES [RS-TR474]	30 mV (8 Ω) (Load impedance 8 - 600 Ω)

■ GENERAL

Power consumption	24 W
Power supply	
For United Kingdom, Europe, Australia and N.Z.	
	AC 50 Hz/60 Hz, 230 V - 240 V
For others	AC 50 Hz/60 Hz, 110 V/127 V/220 V/240 V
Dimensions (W × H × D)	430 × 136 × 285 mm
Weight	4.4 kg

Note:

Specifications are subject to change without notice. Weight and dimensions are approximate.

For United Kingdom

This apparatus was produced to BS 800.

Troubleshooting guide

362

Before requesting service for this unit, check the chart below for a possible cause of the problem you are experiencing. Some simple checks or a minor adjustment on your part may eliminate the problem and restore proper operation.

If you are in doubt about some of the check points, or if the remedies indicated in the chart do not solve the problem, refer to the directory of Authorized Service Centers (enclosed with this unit) to locate a convenient service center, or consult your Technics dealer for instructions.

Problem	Probable cause(s)	Suggested remedy
Tape moves but no sound is heard.	The volume control of the receiver is set to its minimum position.	• Adjust the volume control to the desired level.
	The input selector of the receiver is not set to the "TAPE" position.	• Set to the "TAPE" position.
Distorted sound.	The recording level is too high.	• Select the appropriate recording level.
Previously recorded sound has not been erased.	Erase head is dirty.	• Clean the head.
Sound output is hoarse or unsteady.	Heads are dirty.	• Clean the heads.
	Tape is damaged.	• Try operation with a new cassette; if there is no problem with the new cassette, discard the damaged cassette.
Poor sound quality (especially in the high treble and low bass ranges).	The correct Dolby noise-reduction button is not set.	• Set it to the correct position.
Sound is low, poor tone, intermittent sound noise.	Heads, capstan and/or pinch roller are dirty or tape is damaged.	• Clean the heads, capstan and/or pinch roller, or try a new cassette.
A "hum" noise is heard during tape playback or recording.	This unit is placed too close to a receiver, amplifier or tuner.	• Leave as much space as possible between the units, or place them where there is the least amount of "hum".
Recording is not possible.	The recording level control is at the "0" position.	• Select the appropriate recording level.
	One of the tape-to-tape recording-speed indicators ("x1" or "x2") is illuminated.	• Switch OFF whichever tape-to-tape recording speed indicator is illuminated (by pressing the SPEED button).
TV noise is accidentally recorded.	This unit is placed near a TV.	• Try placing this unit further away from a TV.

Matsushita Electric Industrial Co., Ltd.
Central P.O. Box 288, Osaka 530-91, Japan